



MARK

LE MACCHINE PER GELATO - THE ICE CREAM MACHINES

CONTINUOUS FREEZERS

GELMARK

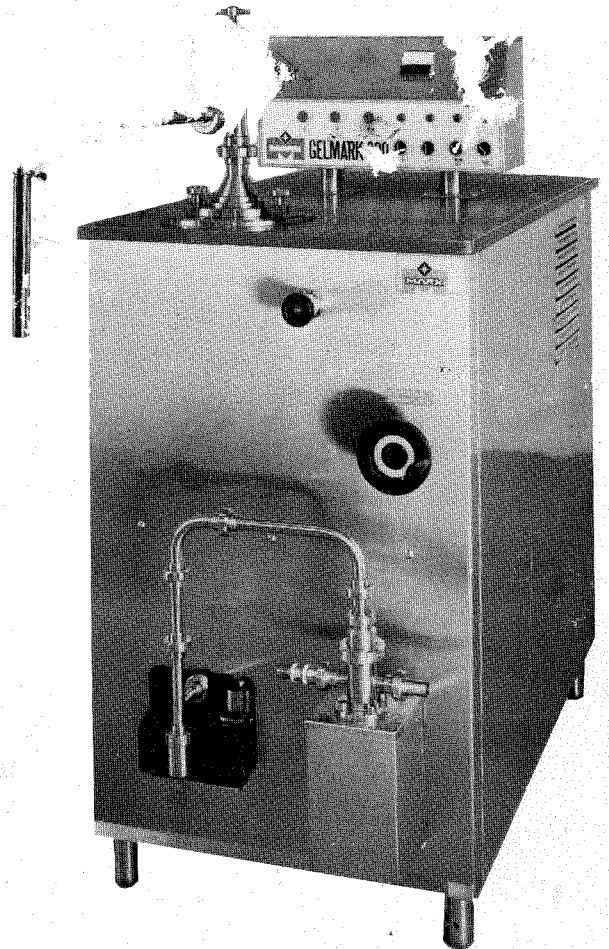

**Instructions for installation,
use and maintenance**

86/07/1 C.G.S.



MARK S.p.A.

Via Monferrato, 52 - Zona Industriale - 20098 SAN GIULIANO MILANESE (Italia)

☎ (02) 98.80.201/2/3/4 - ✉ MARK-SANGIULIANO MILANESE - Telex 315127 MARK I

Export Department: **MARKEXPORT S.p.A.** - Via della Liberazione - Loc. Civesio

20098 San Giuliano Milanese - ☎ (02) 98.48.166/67/68/69 - ✉ MARKEXPORT - SANGIULIANO MILANESE
Telex 321351 MARK I

We wish to initially thank you for the preference accorded us as shown by your having chosen our continuous ice-cream freezers.

Please attentively read the instructions given in this manual.

They shall be very useful for a long and trouble-free operation of the units themselves.

On our part, we can assure you of the use of top-quality materials as produced by first-rate companies; of the accurateness of the preshipment inspecting and testing; and of a tenacious and constant willingness to assist you to the best of our ability.

MARK S.p.A.

The continuous ice-cream freezers of the "GELMARK" series are made entirely of stainless steel.

Each continuous ice-cream freezer is equipped with dismantable side panels. This feature makes for easy access to the inside for cleaning, inspection and maintenance.

And each one is also equipped with four, adjustable, base supporting feet (12) for its subsequent installation in a horizontally level position on the floor.

The main part of each continuous ice-cream freezer consists of :

- a vertical, freezing cylinder with a dasher shaft, scraper blades and an electric motor;
- a refrigeration, motor-powered compressor of the semi-airtight type and relative refrigeration system; and an
- air-mixture pump control group.

On the front part of each continuous ice-cream freezer, there are arranged and installed the :

- air-mixture pump (16) and its relative support (137) and the
- air-mixture pump speed control handwheel.

On the control panel (1), there are arranged and installed all the electronic control and operation equipment for the various parts of the continuous ice-cream freezer.

Above each switch, there is arranged and installed its relative indicating light and, below it, the symbol of the part actuated.

For the control of the operation of the continuous ice-cream freezer, there are, moreover, the :

- ammeter (10) which indicates the electrical energy absorbed by the dasher shaft motor and, consequently, the "hardness" of the ice-cream in the relative freezing cylinder;
- vacuum gauge (11) which indicates the suction of the cooling gas to the compressors; and the
- hygienic pipes (19) complete with a pressure gauge (133) and a vacuum gauge (134) for the control of the pressure and the quantity of air immitted into the mixture; pipe end fittings; and a safety valve (2).

Each continuous ice-cream freezer of the "GELMARK" series is supplied and delivered complete with a general switch (which has to be installed on a wall) and approximately 3 meters of electric current supply cable.

The client has to attend to the installation of the general switch.

- Arrange the continuous ice-cream freezer in the desired position and then, by screwing the base supporting feet (12) either up or down, place it in a perfectly horizontal position.
- Install the main switch on the wall.
It can be either of the automatic, or fuse, type.
Once it has been installed, then connect it to the electric current supply network.
- Check to be sure that the network voltage is the same as that for which the continuous ice-cream freezer has been designed and manufactured.
- Take off the side panels and check to see that the direction of rotation of the dasher shaft motors is that indicated by the arrows.
In any case, the dasher shaft has to rotate clockwise.
If it does not, then invert one of the phases of the electrical input.
- Check to be sure that the compressor has been released and that it is, as a consequence, free to oscillate on its shock-absorbers.
- Take off the adhesive tape that blocks the blades to the dasher shaft.

N.B. – The continuous ice-cream freezer is shipped from the factory with all the valves of the refrigeration circuit in operating position. Consequently, it is not necessary to actuate them prior to the actual starting of the unit itself.

Connect the pipeline of the water supply system to the hose on which there has been attached a plate with the word "ENTRATA", i.e., "INLET", and then connect the hose on which there has been written the word "SCARICO", i.e., "DISCHARGE", to the water discharge pipeline.

If, for any reason whatsoever, these plates should be missing, then the inlet hose is that one on which the water flow regulating valve (136 - Fig. 2) has been installed.

The connecting hoses must neither have diameters which are less than those of the piping coming from the continuous ice-cream freezer nor must there be any constrictions at any point in their course.

Never use mixtures that have a temperature of more than +4° C to +5° C.

If, for conditions and/or circumstances over which one has little, if any, control, one should be more or less compelled to use mixtures having higher temperatures than those indicated above, then reduce the speed of the pump to the minimum.

CONTROLS AT THE DISPOSAL OF THE USER – FIG. 1-2

Dasher shaft motor switch (8)

Start rotating the dasher shaft of the freezing cylinder.

N.B. – When the continuous ice-cream freezer is in operation, the dasher shaft has to be set rotating.

Whenever the dasher shaft stops, then the refrigeration compressor also automatically comes to a halt.

Hot gas valve switch (13)

This switch makes it possible to send hot gas onto the freezing cylinder, so as to quickly defrost it in case it should be necessary to do so.

Motor-powered compressor switch (14)

This switch serves for starting the refrigerating compressor of the freezing cylinder.

Mixture pump switch (9)

This switch serves for starting the mixture pump.

Dasher shaft thermic resetting pushbutton (21)

This pushbutton serves for restarting the dasher shaft of the freezing cylinder.

Motor-powered compressor thermic resetting pushbutton (20)

This pushbutton serves for restarting the motorized compressor.

Mixture pump thermic resetting pushbutton (22)

This pushbutton serves for restarting the mixture pump.

Dasher shaft motor ammeter (10)

This device indicates the stress of the motor of the dasher shaft in proportion to the hardness of the ice-cream in the freezing cylinder.

Gas vacuum gauge (11)

This gauge indicates the suction temperature of the gas to the motorized compressor in the first freezing cylinder.

Hot gas flow regulating valve (156)

This valve regulates the flow of hot gas to the freezing cylinder, so as to modify the degree of "hardness" of the ice-cream as it comes out from the freezer.

Mixture pump speed varying handwheel (137)

This handwheel regulates the rotation speed of the mixture pump and, consequently, the amount of ice-cream made.

Safety valve (2)

This valve discharges the mixture in case of over-pressure.

Mixture pump pressure gauge (133)

This gauge controls the pressure of the mixture on the inside of the freezing cylinders.

(It is supplied only on specific client request).

Air valve vacuum gauge (134)

This gauge control (indicatively) the quantity of air immitted into the mixture.

(It is supplied only on specific client request).

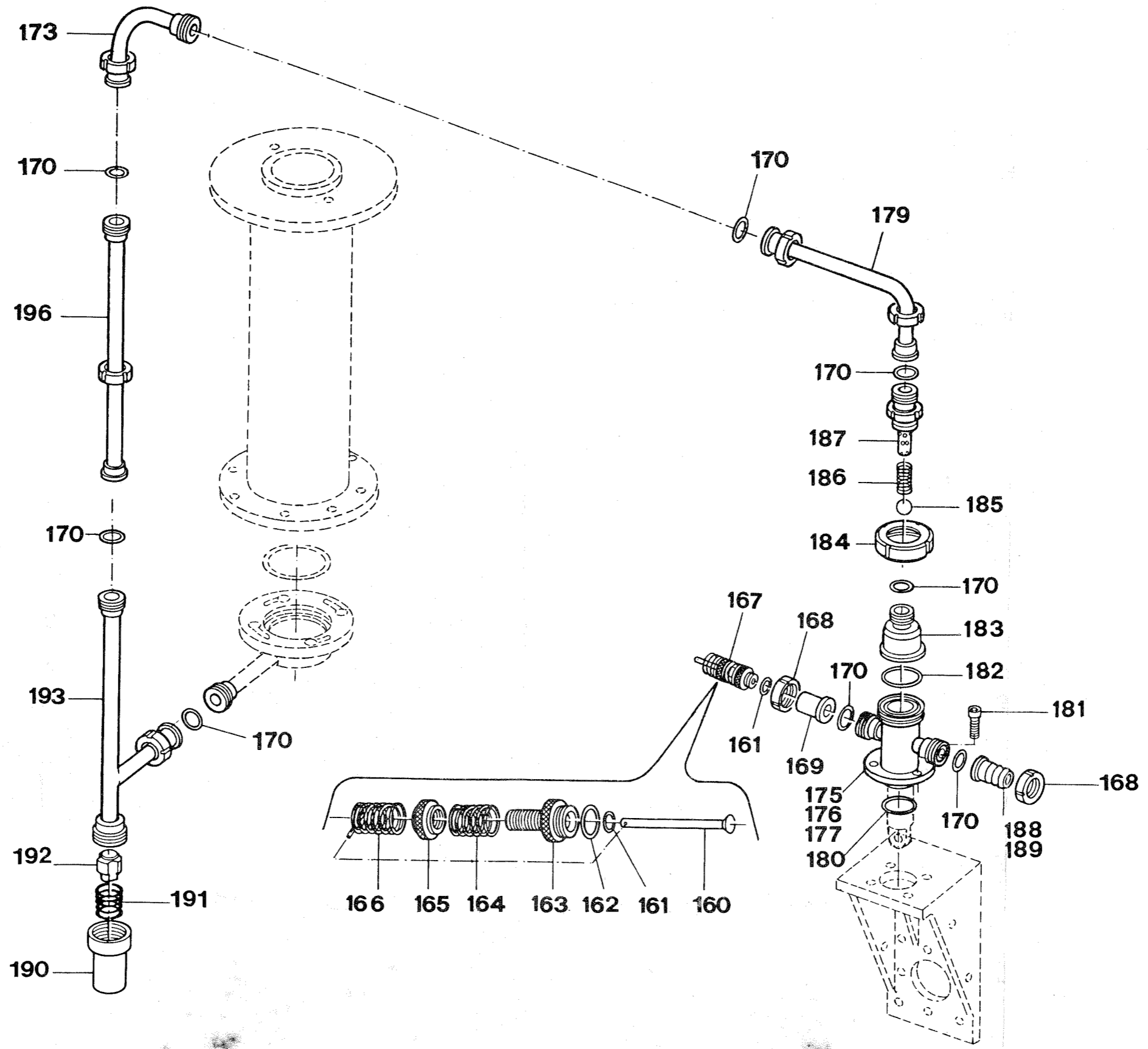

FIG. 5

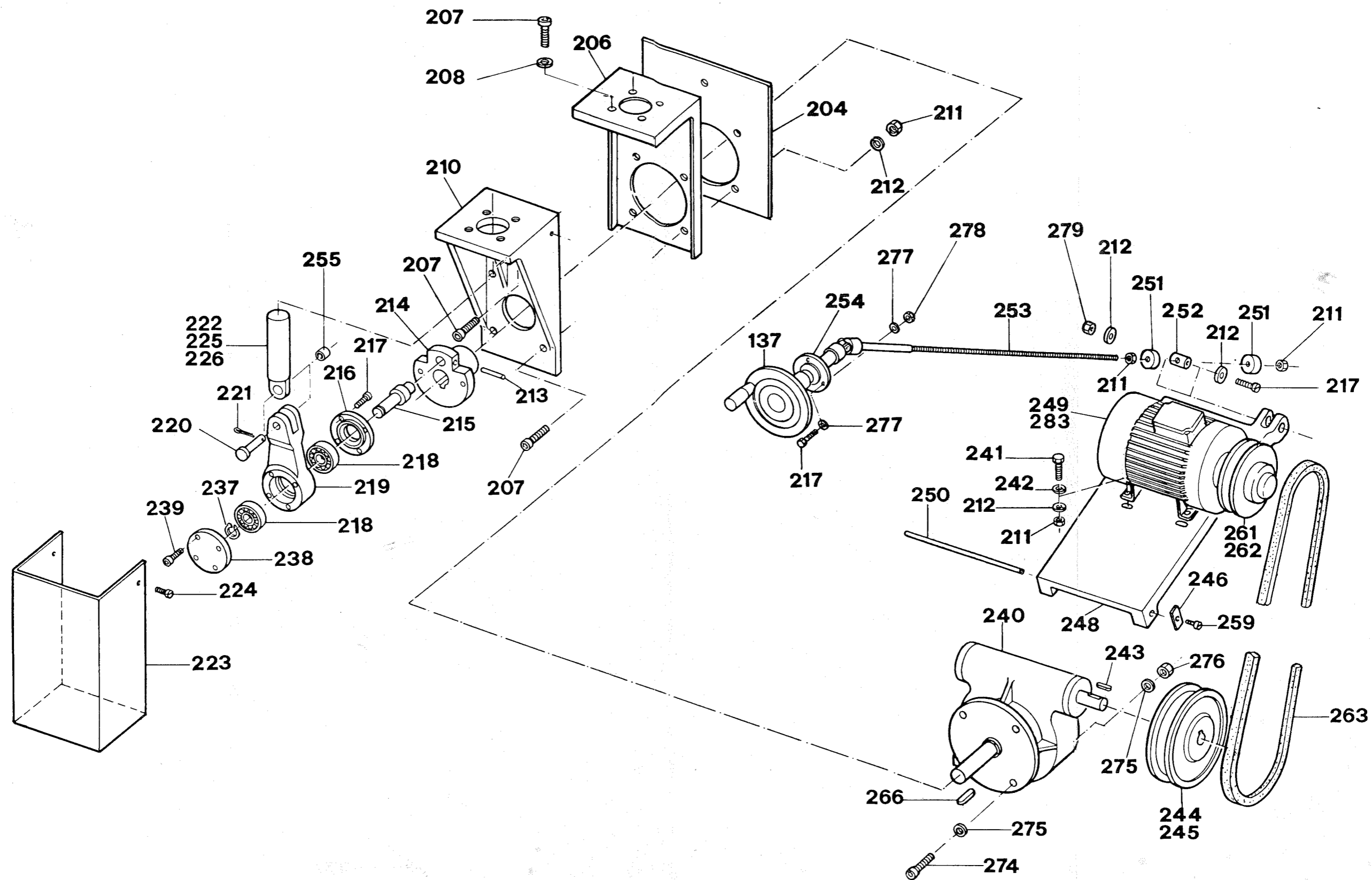

FIG. 6

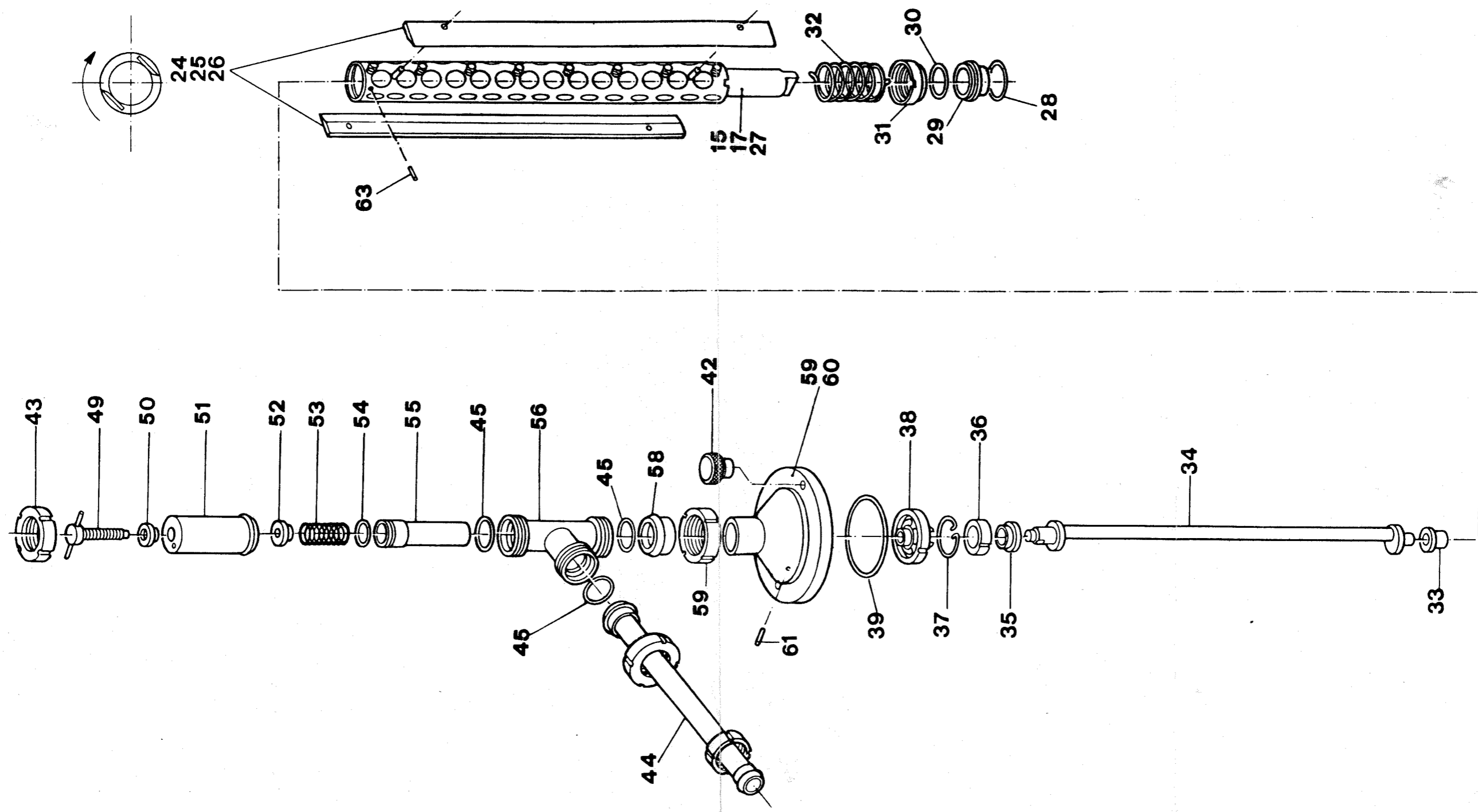

FIG. 3

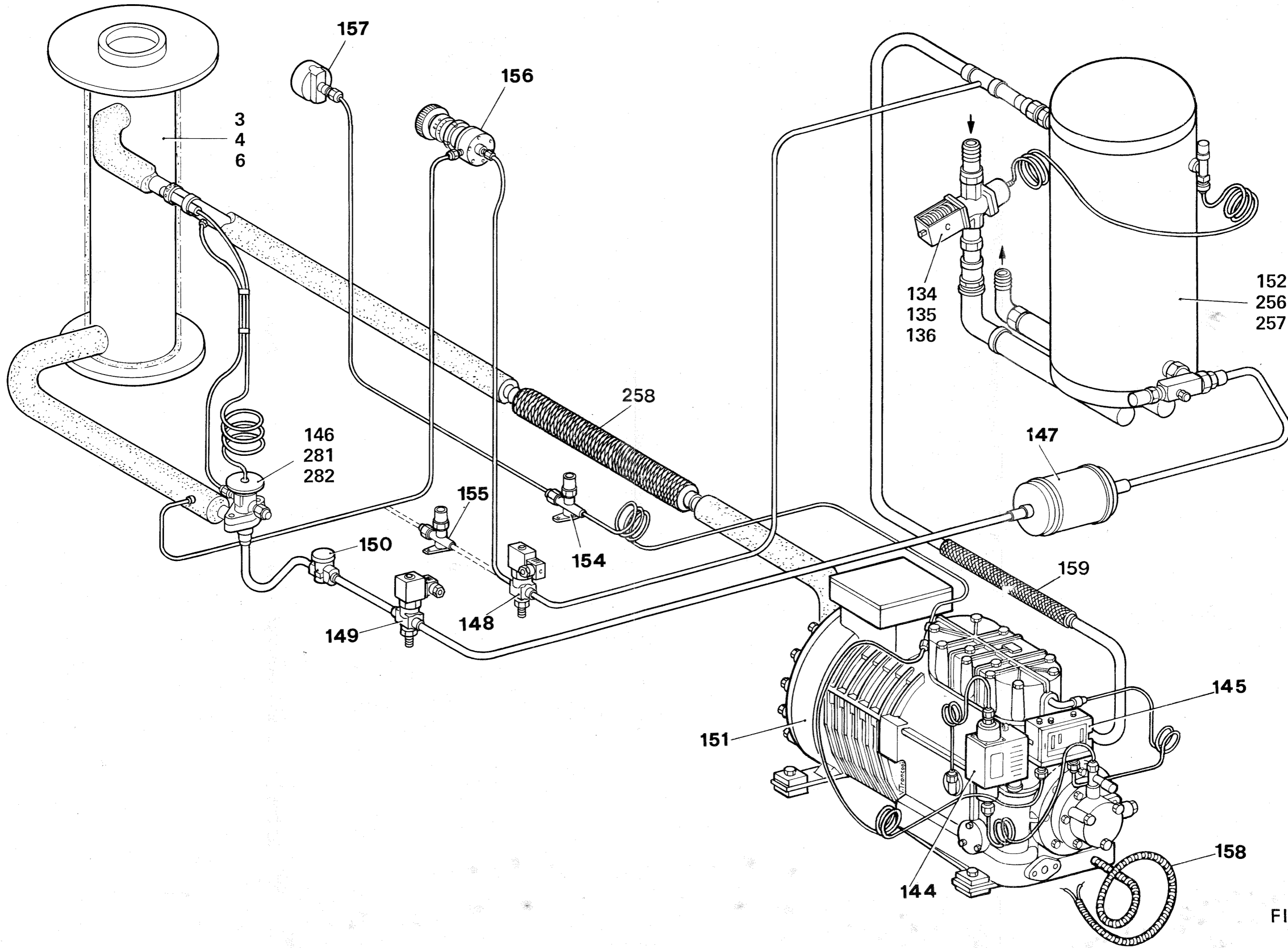

FIG. 7

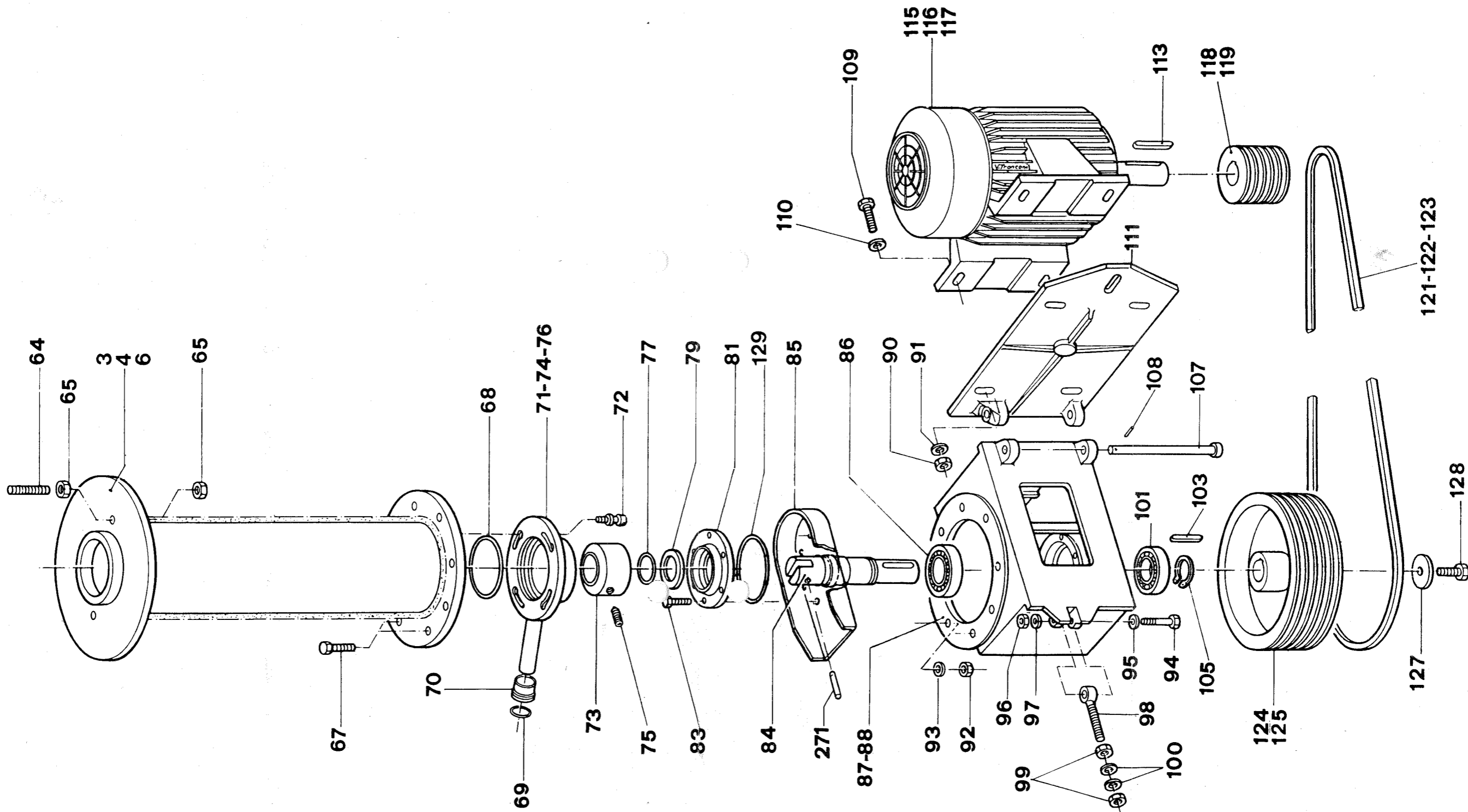

FIG. 4

Cut-in the main wall switch and, in so doing, turn on the continuous ice-cream freezer at least five to six hours before starting the refrigerating compressors.

The resistances (that are arranged and installed in the carter of the refrigerating compressor) will slightly heat the oil and, in so doing, expel any eventual refrigeration gas that may be contained in it.

For the selfsame reason, the main switch must never be cut-out (that is, the continuous ice-cream freezer must not be turned off) at the end of the ice-cream processing cycle, shift and/or working day.

Before beginning to actually make ice-cream, be sure to disinfect and clean the continuous freezer itself. (In this respect, please refer to the section entitled "DAILY CLEANING of the CONTINUOUS ICE-CREAM FREEZER".)

Connect the suction hose of the pump (189) to the receptacle containing the mixture.

Start up the pump by cutting-in the switch (9).

Then, reduce the flow of the mixture to the minimum by turning the hand-wheel (137) toward the sign (-).

Wait until the mixture begins to flow out from the pipe (5), and then stop the pump.

After having stopped the pump, then cut-in the switch (8), so as to set in motion the dasher shaft, and then cut-in the switch (14) for starting the refrigerating compressor.

Once these preliminary operations have been completed, there then begins the hardening of the mixture on the inside of the freezing cylinder.

The degree of hardness of the mixture can be controlled by means of the ammeter (10) which, in turn, indicates the stress to which the motor is being subjected in proportion to the hardness of the ice-cream.

When the mixture has attained the desired degree of hardness, then start up the pump once again and regulate both the flow of the mixture and the quantity of air to immit into it as described in the next section.

REGULATION OF THE AIR TO BE IMMITTED INTO THE MIXTURE FIG. 1-5

For the regulation and the control of the air to be immitted into the mixture, the continuous ice-cream freezers of the "GELMARK" series are supplied and delivered equipped with an air valve (167).

On rotating the knurled ring nut (165), the quantity of air to be immitted into the mixture can be varied.

When starting to make ice-cream, i.e., when the pump is set in motion, it is advisable to keep the air valve (167) partially closed.

So as to partially close the air valve turn the knurled ring nut (165) counter-clockwise.

In this state, the quantity of air immitted into the mixture is minimal.

After a couple of minutes time from the emergence of the ice-cream from the freezer, slowly rotate the knurled ring nut (165) clockwise, so as to immit more air into the cylinder.

At this particular point, the overrun can be checked.

If the percentage of air is not yet that which one wishes to have, then it can be increased, or decreased, as the case may be, by either opening, or closing, the relative air valve and, in so doing, subsequently obtain the exact increase in volume wanted.

Each time the air valve is opened or closed, several minutes time shall have to pass before all of the ice-cream will feel the effect of the variation effected.

In those continuous ice-cream freezers equipped with a vacuum gauge (134), the pointer of the vacuum gauge itself will indicate 30 to 40 mm. Hg ca. when the air valve has been almost completely closed.

When the desired quantity of air to be immitted into the mixtures has finally been resolved upon and attained, then the pointer of the vacuum gauge will indicate a certain numerical value which, in turn, will serve as a reference point, so to speak, for the next time, so as to be able to bring the continuous ice-cream freezer up to operating level in a shorter period of time.

However, sight must not be lost of the fact that the numerical value indicated by the vacuum gauge will change, albeit slightly, according to the kind of mixture used.

N.B. — If, on closing the air valve, the pointer of the vacuum gauge does not move downwards, then this means that there is a leak at some point in the pipeline that goes from the pump to the air valve itself. The factor can, in turn, be due to a loose pipe end fitting or to a fitting without a gasket.

The check valve (142) eliminates the oscillation of the vacuum gauge and, as a direct and natural result, keeps its pointer (to all practical intents and purposes) steady.

It is advisable, at periodic intervals, to unscrew and remove the check valve from its relative housing and inspect the state of the gaskets (170 — Fig. 5). If they are worn, then replace them with other, new ones.

REGULATION OF THE PRESSURE ON THE INSIDE OF THE CYLINDER FIG. 1-3

If the continuous ice-cream freezer is also equipped with a pump pressure gauge (131) for the control of the pressure of the mixture on the inside of the cylinder, then this gauge ought to indicate a pressure from between 6 and 9 kg./sq. cm.

If the pressure should drop down below these levels, then it could be too low and, as a consequence, cause difficulties in maintaining constant the production of ice-cream.

So as to be able to resume making ice-cream after an interruption in production, check to be sure that the:

- 1) speed of the air/mixture pump is not too high;
- 2) temperature of the mixture coming from the vats is not too high and, as a consequence, the ice-cream produced is not too soft;

and that:

- 3) there is something wrong in the refrigeration system which, in turn, diminishes its productive capacity and causes, as a direct and natural result, ice-cream (which is not too hard) to come out from the freezer.

While the first two conditions can be more or less immediately rectified by modifying the relative adjusting screws, the refrigeration system has, on the other hand, to be inspected by a specialist, i.e., by a highly qualified refrigeration technician and by adhering to the instructions given in the section entitled "MAINTENANCE".

If, on the other hand, the pressure exceeds 10 kg./sq. cm., it has to be considered as being too high, but it can, nonetheless, be reduced in the following ways, viz.:

- 1) check to be sure that there are no kinks or constrictions in the ice-cream outlet hose and that it is not, in any case, more than 3 to 5 meters in length.
- 2) loosen the adjusting screw (49) all the way;
- 3) increase the speed of the pump by turning the handwheel (137);
- 4) use the hot gas valve (156) in the way described in that which follows.

In any case, the "GELMARK" continuous type ice-cream freezers have a special safety valve (2) that automatically begins to open whenever the pressure exceeds 12 kg./sq. cm., so as to avoid the creation of abnormal pressures which could, in turn, be detrimental to the trouble-free operation of the continuous ice-cream freezer itself.

Do NOT (in any way, shape or form) tamper with the setting of the safety valve and, in case it should cut-in, then check to see just what it was that caused it to be activated in the first place.

N.B. - Absolutely do not press the membrane of the pressure gauge and/or that of the vacuum gauge with the tips of one's fingers.

In the event that either the one, or the other, has to be disassembled for cleaning the continuous ice-cream freezer, then the maximum attention has to be given to reinstalling them, because if they should become mixed up and, as a consequence, one taken for the other, then they would be irreparably damaged.

REGULATION OF THE "HARDNESS" OF THE ICE-CREAM - FIG. 1

The refrigeration system is equipped with a device for the partial recirculation of the hot gas.

This "hot gas" device can be used as a regulator of the degree of hardness of the ice-cream and especially so whenever one wants to obtain an ice-cream suitable for being inserted in molds, or for the production of ice-cream on a stick, or whenever one intends to reduce the production capacity of the continuous ice-cream freezer itself.

In any one of these three cases, proceed as follows:

- 1) set the continuous ice-cream freezer in operation and then adjust the speed of the pump until the required production rate has been attained;
- 2) close the hot gas regulating valve (156);
- 3) cut-in the switch (13), so as to subsequently be able to open the hot gas valve;
- 4) slowly begin to open the hot gas regulating valve (156) and continue doing so until the ice-cream with the desired consistency is obtained.

The hot gas valves may also be used in an emergency, e.g., whenever there should be a sudden and unforeseen interruption in the supply of electrical energy, or if the mixture pump should, for any reason whatsoever, come to a halt.

In case such as these, since the ice-cream would remain on the inside of the freezing cylinder for a longer period of time than necessary, it would become excessively hard and, as such, block the dasher shaft.

Under conditions and circumstances such as these, it is necessary to immediately turn off the motor of the dasher shaft of the compressor.

Next, turn the knob switch (13 - Fig. 1) that opens the solenoid valve of the hot gas and then open the regulating valve (156) all the way.

Wait for about two minutes, so as to give the ice-cream (on the inside of the freezing cylinder) a chance to become soft.

REGULATION OF THE "HARDNESS" OF THE ICE-CREAM (cont'd)

Afterwards, cut-out the knob switch (13) and also close the regulating valve (156).

Once this stage has been reached, then the continuous ice-cream freezer is ready to resume normal production.

CLEANING OF THE CONTINUOUS ICE-CREAM FREEZER

At the end of each day's operations, or at the end of each production cycle, the continuous ice-cream freezer has to be thoroughly washed and sanitized.

To do so, disassemble all the parts that have come in contact with the mixture.

In particular, when taking off the dasher shaft, use the special threaded ring and the plastic protective ones, so as to avoid damaging the freezing cylinder.

Immerse the disassembled parts in a special detergent solution.

(The quantity of detergent to be used shall be specified by its manufacturer and/or supplier).

Carefully wash these disassembled parts.

Afterwards, thoroughly rinse them with clean water.

Then, reinstall them.

Be sure to reinstall these disassembled parts in exactly the same positions they were in before.

In case of doubt, revert to the figures and the drawings in the back part of this manual.

Sanitize the continuous ice-cream freezer by making the pump suck up a solution containing an appropriate sterilizing liquid.

Once having done so, then let this sterilizing solution run out from the continuous ice-cream freezer.

Afterwards, thoroughly rinse it.

At this point, the continuous ice-cream freezer is ready to be used, again.

N.B. - Those products used for washing and sanitizing the continuous ice-cream freezer must not corrode the mechanical parts with which they come in contact.

In case the type of production has to be changed, then all one has to do is to add a natural detergent to the water; set the pump and the dasher shaft in motion; and then have the pump suck up this solution into the continuous ice-cream freezer.

So as to rinse out to continuous ice-cream freezer, all one has to do is but to repeat this operation with clean water.

CLEANING OF THE CONTINUOUS ICE-CREAM FREEZER (cont'd)

To drain out the water, stop the motor and then loosen the pipe end fittings. (19)

Once this stage has been attained, then the continuous ice-cream freezer is ready to be used, again.

CLEANING OF THE CONTINUOUS ICE-CREAM FREEZER "C.I.P." WASHING

The "C.I.P." washing is a rational method for cleaning the continuous ice-cream freezer and without having to disassemble all the parts that have come in contact with the mixture.

To do so, proceed as follows:

- 1) So as to rinse out the continuous ice-cream freezer a first time, set the dasher shaft in motion and then make the pump suck up cold, or lukewarm, water into it.
- 2) In a special receptacle that is apt and suitable to the end in view, e.g., the "washing tank with a built-in "MARK" pump", add a detergent (as per instructions) to 100-150 liters of water at a temperature of 40-50°C. This pump (or a similar one that is capable of producing a considerable degree of pressure) will impel the solution into the cylinder.
- 3) Take off the safety valve (2 - Fig. 1); screw on a double junction; and then connect the pump as shown in the relative drawing.
- 4) Set in motion the washing pump, the freezer pump and the dasher shaft. The solution (that has to circulate in the freezing cylinder for 20 minutes ca.) can be salvaged and then conveyed to the recovery tank by means of a hygienically clean hose.
- 5) Rinse out the continuous ice-cream freezer with clean water. In doing so, follow the same procedure described in the preceding point.
- 6) To sanitize the continuous ice-cream freezer, add disinfectant to 50-100 liters of clean water.
(The quantity of disinfectant to be used shall be specified by its manufacturer and/or supplier.)
By means of the high pressure pump, make this disinfectant solution circulate throughout the whole continuous ice-cream freezer for approximately five minutes.
While doing so, do not turn off the freezer pump or stop the dasher shaft, but let them keep running.
- 7) At the end of the aforementioned time period, let this disinfectant solution run out from the continuous ice-cream freezer.
To do so, loosen the double junction.
Then, put the safety valve (2 - Fig. 1) back in place.
The continuous ice-cream freezer is now ready for a new production cycle.

CLEANING OF THE CONTINUOUS ICE-CREAM FREEZER "C.I.P." WASHING (cont'd)

N.B. - After having disinfected it, do not disassembly any part of the continuous ice-cream freezer, so as to avoid possible contamination.

The products used for washing and disinfecting the continuous ice-cream freezer must not corrode the mechanical parts with which they come in contact.

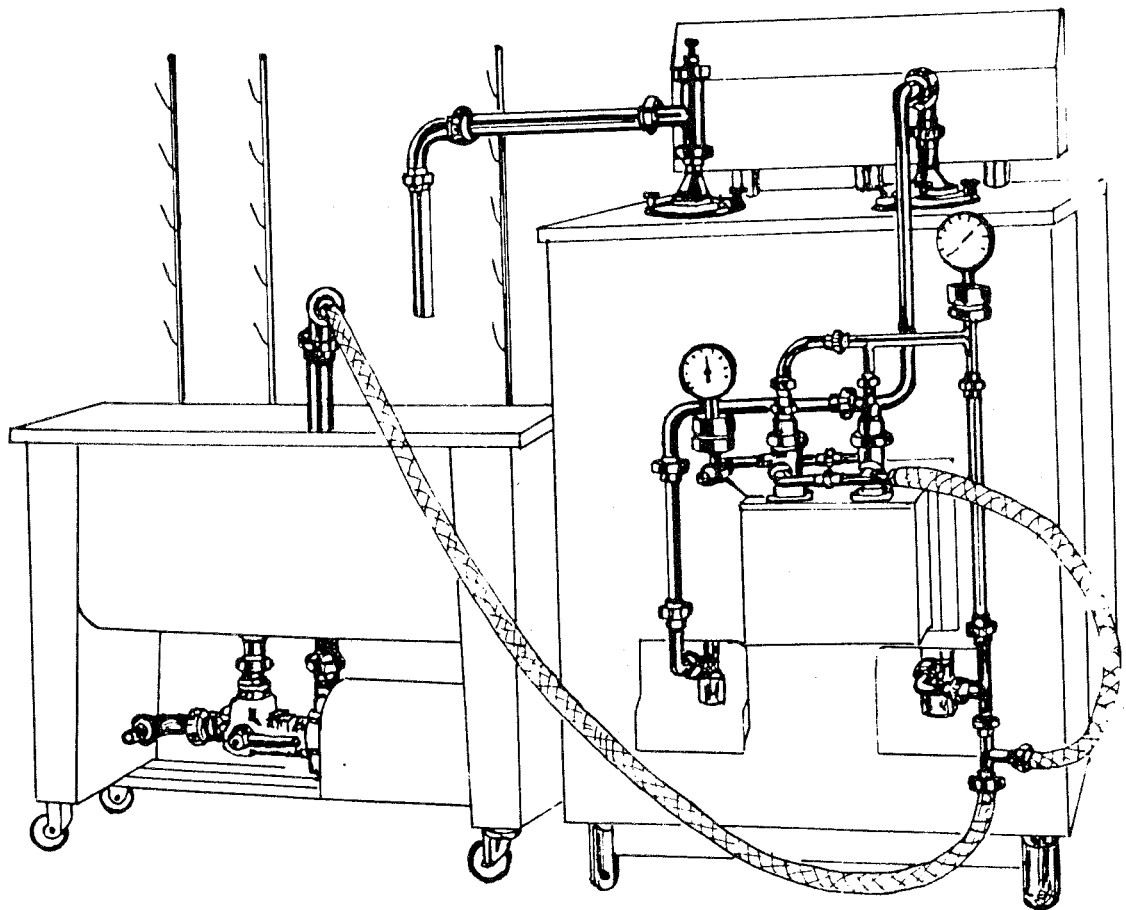

An example of "C.I.P." washing with "MARK" equipment

It is of the maximum importance to periodically inspect the various component parts of the continuous ice-cream freezer, and especially so after long seasonal pauses, so as to subsequently avoid any inconvenience when the maximum efficiency and uninterrupted production is demanded of it.

We here at MARK S.p.A. will never tire of telling this to our clients. It is in their own best interest!

The maintenance of the "GELMARK" models is of three kinds, viz., mechanical, electric and frigorific.

MECHANICAL MAINTENANCE – FIG. 2-3-4-5-6-7

The maintenance of the mechanical parts consists in :

a) **Base supports**

Inspect the base supports (88 - Fig. 4).

On each of these base supports, there are installed bearings, gaskets, a pulley and the main shaft.

If (during operation) a shaft should become noisy, then disassemble it. In doing so, follow the indications given in Fig. 3 and 4.

Replace the worn gaskets and bearings.

Reinstall the entire assembly with the maximum attention.

Check to be sure that there is no play in the housings of the shaft and the bearings.

b) **Bushings**

Inspect the bushings (29 - Fig. 3) in which the dasher shaft rotates. If they are worn, replace them.

c) **Scraper blades**

Inspect the scraper blades (26).

They have to be arranged and installed on their relative pins in such a way and to such an extent that they cannot come out during the processing of the ice-cream.

If the edge of the blade should be marred by nicks, dents, or what have you, then hone it, or else remove it and replace it with a new one.

N.B. - Correctly reinstall it as shown in Fig. 3.

d) **Rotating seals**

Inspect the rotating seals installed on the bottom of the dasher shaft (Fig. 3).

The housing of the rotating seal (31) is faced in hard metal which, on being pressed by the spring (32), grazes against the face of the bushing (29).

These two surfaces have always to be specular, i.e., polished to a mirror-like state, otherwise the mixture will come out from the lower part of the cylinder.

So as to smooth and polish the two surfaces to a high gloss, use a fine grade of sandpaper.

Initially rub them against a very hard surface (glass), and then one against the other, and in the same way as one would in grinding the valves.

If the ring type gaskets are worn, then replace them.

e) Main shaft and pump belts

Inspect the belts of the main shaft and of the pump.

The belts of the main shaft must not be excessively taut and they all have to always have the same degree of tautness.

Never substitute but a single belt but, on the contrary, replace all of them at one and the same time.

If the belt of the pump speed variator is worn, then replace it.

ELECTRICAL SYSTEM MAINTENANCE – FIG. 1-2

The electrical system has been conceived, designed and developed so as to protect to the maximum the components of the continuous ice-cream freezer.

Whenever a motor stops running, then proceed as follows:

- a) Wait a couple of seconds and then (for the thermic resetting) press that one of the blue pushbuttons (20, 21 or 22 - Fig. 1) under which there is the symbol relative to that particular motor which has stopped running.
- b) If the motor refuses to turn over, then check the fuses of the wall-installed switch and those of the fuse holders installed in the control panel.
- c) When, instead, a motorized compressor stops running (and in addition to the thermic resetting), it shall also be necessary to check the pressure switch (145), as well as the electronic protection (that is usually installed in the terminal board of the motorized compressor itself) and the contacts of which could either be open due to their intervention, or else defective.

These operations have to be done before intervening on the electrical system.

Attentively follow and strictly adhere to the electrical wiring diagram.

The terminal board numbered on the relative electrical wiring diagram duplicates that one installed on the continuous ice-cream freezer. As a consequence, it facilitates control procedures.

For maintenance, and eventual repairs, it is advisable to have recourse to the services of a qualified electrician.

REFRIGERATION SYSTEM MAINTENANCE – FIG. 1-2-7

Any and all checks and controls of, as well as any eventual repairs to, the refrigeration system have to be done only by a highly qualified refrigeration technician.

In the event that the refrigeration system does not function as it should, then the reasons why may be due to one or more of the following factors.

- 1) insufficient condensation;
- 2) thermostatic valve (146) is not properly set or else it is inefficient;
- 3) circuit filter (147) is dirty or else it is clogged;
- 4) hot gas solenoid valve (148) is either blocked or else it is open;
- 5) solenoid valve (149) is either blocked or else it is closed;
- 6) there is a lack of gas in the refrigeration system.

Insufficient condensation can be due to:

- a) a lack of water coming from the water supply system;

or:

- b) the regulating valve (136) is not properly adjusted.

In the first case, check to be sure that all the circuit valves (that convey water to the continuous ice-cream freezer) are open and that the flow of water to the continuous ice-cream freezer itself is uninterrupted.

In the second case, so as to adjust the water flow regulating valve (136) either tighten or loosen, as the case may be, the screw (or cap) installed in the head of the valve itself.

If the water flow regulating valve is properly adjusted, then the temperature of the water (coming out from the discharge outlet and with the refrigeration system in operation) should be from $+30^{\circ}\text{C}$ to $+35^{\circ}\text{C}$ ca.

If the thermostatic valve (146) is not properly set, then it can result in a considerable reduction in the refrigerating capacity of the entire system.

The thermostatic valve has to be set in such a way that the vacuum gauge (11 - Fig. 1), during operation, indicates a temperature of from -26°C to -30°C .

If the circuit filter (147) is clogged, then it becomes covered with frost. Consequently, disassemble it and replace it. In any case, it has always to be replaced each time the refrigeration circuit is opened.

If the solenoid valve (148) (that controls the hot gas) remains open, it results in a considerable decrease in the refrigerating capacity and the vacuum gauge (11 - Fig. 1) rises to more than $+20^{\circ}\text{C}$.

If this should happen, then inspect the solenoid valve and replace the worn parts.

The solenoid valve (149) automatically closes the cooling liquid circuit whenever the refrigeration compressor stops running.

If this solenoid valve does not open, then the refrigeration system tends to become a vacuum.

Moreover, the vacuum gauge (11 – Fig. 1) drops down to more than -35°C .

In the event that this should happen, then check to be sure that the solenoid valve is being supplied with electrical current.

If it is not being so supplied, then replace it.

If the electrical system is in order, and all the above-mentioned points result to be okay, then the subsequent insufficient refrigerating capacity is due to a lack of gas in the refrigeration system.

A lack of gas in the refrigeration system (under normal operating conditions and circumstances) is revealed by the presence of gas bubbles that can be seen by looking through the sight gauge (150 – Fig. 2).

Whenever a lack of gas in the refrigeration system has been ascertained, and before taking the time and trouble to add additional gas, look for the reasons that caused the preceding gas to escape.

If it is absolutely not necessary to do so, do not add gas to the refrigeration circuit: to do so, is nothing more nor less than a waste of time, money and energy!

A refrigeration system with too much gas just does not work!

At regular intervals, check the level of the oil in the refrigerating compressor by looking through the relative sight gauge.

In effecting any and all checks and controls, always revert to the drawings and diagrams in the back of this manual.

When ordering separate parts, always mention the construction serial number, the drawing number and the part number given in the manual.

DUE TO CONTINUOUS TECHNOLOGICAL DEVELOPMENTS AND IMPROVEMENTS, THE DIMENSIONS AND THE DATA GIVEN IN THIS MANUAL ARE NOT BINDING AND CAN BE CHANGED WITHOUT ANY PRIOR NOTICE ON OUR PART.

TECHNICAL CHARACTERISTICS

		"GM/80"	"GM/160"	"GM/300"
Dasher shaft motor	HP	1.5	3	4
Mixture pump motor	HP	0.5	1	1
Frigorific motorized compressor	HP	2	4	7.5
Total electric rating	Kw	3	6	9.2
Frigorific capacity (at -30°C/+30°C)	fg./hr	2,400	4,300	7,300
Type of coolant		R 22	R 22	R 22
Condensation water *				
– network (+15° to 18°C)	kt./hr.	190	350	600
– minimum pressure: 1.5				

* With tower water, remove or completely open the water pressure switch valve (136) by turning the head screw.

OIL			NOTES
Frigorific compressor TYPE – Density (at +15°C) – Viscosity (at +50°C) – Pour point – Quantity	kg./cu. mt. °E °C Kg.	"SUNISO 3-G" 9,4 2,7 -40 3.8	The refrigeration compressor is life-time lubricated. If necessary, top the level off up to 3/4ths of the level of the glass level gauge on the housing of the refrigeration compressor.
Reduction gears and Pump gearbox TYPE – Density (at +15°C) – Viscosity (at +50°C) – Pour point	kg./cu. mt. °E °C	"SAE 90" 900 13 -18	After the first 1,500 hours of operation, change the oil. If possible, thoroughly wash the inside of the reduction gear. Periodically check the oil level. Completely change the oil after 4,000 hours of operation.
Bushings (255) - Fig. 6	TYPE	Bearing grease	Every 500 hours of operation, grease the bushings as needed.
Variable pulley (261) - Fig. 6	TYPE	Bearing grease	Every 1,000 hours of operation, grease the variable pulley with the grease gun supplied for this purpose.

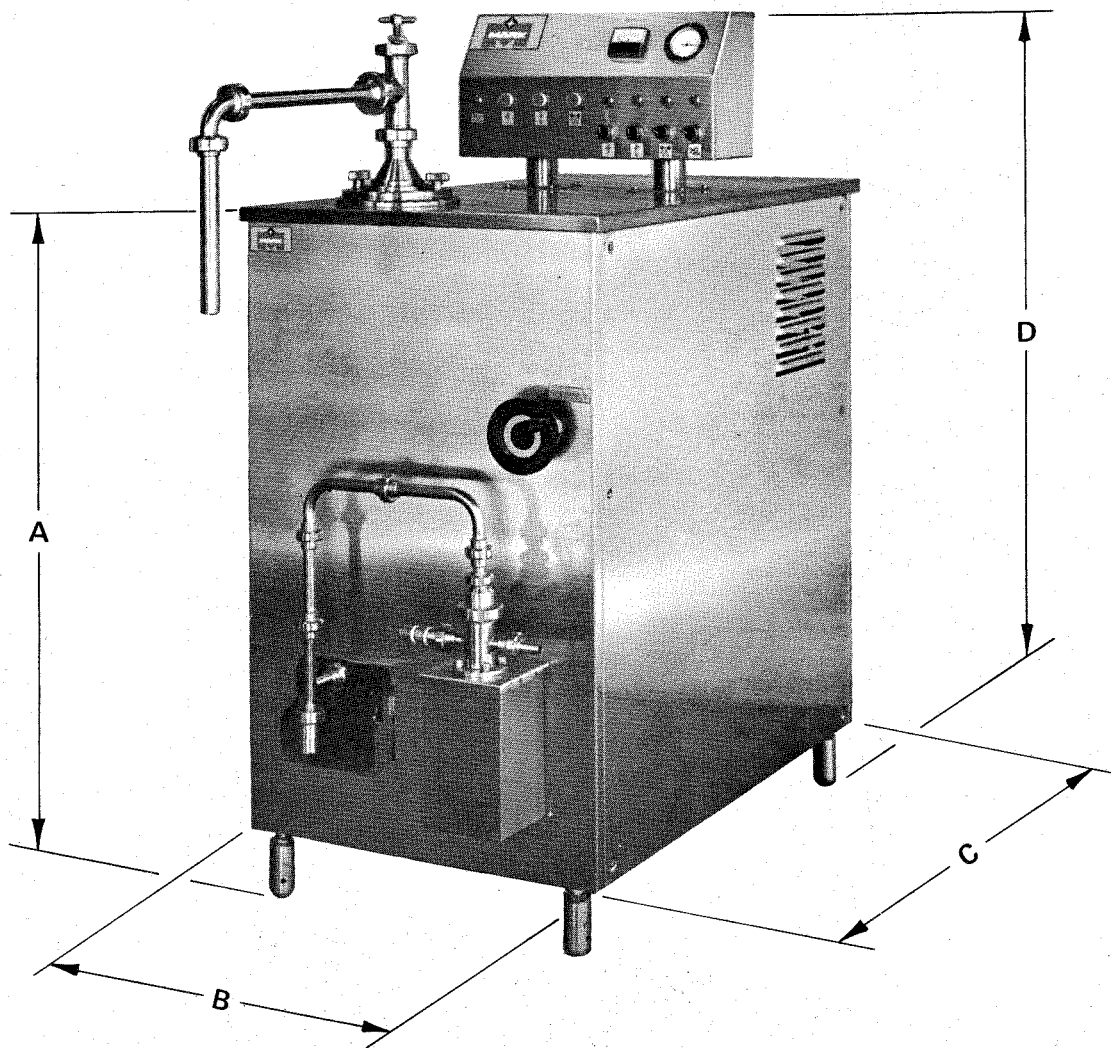

	A		B		C		D		Kg.	lb.
GM/80	980	39"	580	23"	820	32"	1280	50"	210	462
GM/160	1070	42"	670	26"	930	37"	1410	56"	330	728
GM/300	1230	48"	750	30"	1150	45"	1570	62"	520	1146

COMPONENT PARTS

Part. N°	Description		Fig.
1	Control panel housing		1
2	Safety valve		1
3	Freezer cylinder	GM/80	2-4-7
4	Freezer cylinder	GM/160	2-4-7
5	Ice-cream outflow pipe		1
6	Freezer cylinder	GM/300	2-4-7
8	Dasher shaft switch		1
9	Mixture pump switch		1
10	Ammeter		1
11	Vacuum gauge		1
12	Base supporting foot		1
13	Hot gas valve switch		1
14	Refrigeration compressor switch		1
15	Bored dasher shaft	GM/80	3
16	Mixture pump rubber holder		1
17	Bored dasher shaft	GM/160	3
18	Mixture inlet pipe end fitting		1
19	Mixture pipeline		1
20	Compressor thermic resetting pushbutton		1
21	Dasher shaft thermic resetting pushbutton		1
22	Pump thermic resetting pushbutton		1
23	Hot gas shutter valve adjusting screw		1
24	Inox blade Dim 600 x 25 x 2,5	GM/160	3
25	Inox blade Dim 800 x 30 x 2,5	GM/300	3
26	Inox blade Dim 296 x 23 x 2,5	GM/80	
27	Bored dasher shaft		3
28	"OR" 6715 gasket - I.D.: 43.82 mm. - THK.: 5.34 mm.		3
29	Rotating seal bushing		3
30	"OR" 6162 gasket - I.D.: 40.55 mm - THK.: 5.34 mm		3
31	Rotating seal counter-seat		3
32	Rotating seal spring		3
33	Lower bushing		3
34	Eccentric		3
35	Upper bushing		3
36	Eccentric upper support		3
37	Upper seal fing		3
38	Dasher shaft upper support		3
39	"OR" 6412 gasket - I.D.: 104.1 mm - THK.: 5.34 mm		3
42	Cover knob		3
43	Rotating device - DN 40		3
44	Pipe		3
45	Gasket - DN 40		3
49	Outlet adjusting screw		3
50	Outlet adjusting check nut		3
51	Upper bush		3
52	Upper spring holder		3
53	Ice-cream outlet spring		3
54	"OR" 4131 gasket - I.D.: 32.93 mm - THK.: 3.53 mm		3
55	Ice-cream outlet spring holding buffer		3
56	Mixture outlet double junction		3

COMPONENT PARTS (cont'd)

Part. N°	Description		Fig.
59	Ice-cream outlet upper flange	GM/300	1-3
60	Ice-cream outlet upper flange	GM/80-160	1-3
61	Cover pin		3
63	Dasher shaft pin		3
64	All-thread puller		4
65	Hexagonal nut		4
66	Freezer cylinder		4
67	Hex-head screw		4
68	"OR" 4375 gasket - I.D. : 94,84 - THK. : 3,53 mm		4
69	"OR" 4100 gasket		4
70	Female threader - DN21		4
71	Lower plate		4
72	Lower plate fastening pin		4
73	Main shaft reinforcing ring nut		4
74	Lower plate	GM/160	4
75	Countersunk head screw retaining dowel		4
76	Lower plate	GM/300	4
77	"OR" 3156 gasket - I.D. : 39,34 mm - THK. : 2,62 mm		4
79	"Corteco" 5065 - 8 gasket - I.D. : 50 mm - O.D. : 65 mm - THK. : 8 mm		4
81	Bearing cover		4
83	Hex-head screw		4
84	Main shaft		4
85	Drop collector		4
86	"SKF" bearing - 6011-2RS		4
87	Aluminium support	GM/80-160	4
88	Aluminium support	GM/300	4
90	Hexagonal nut		4
91	Smooth washer		4
92	Hexagonal nut		4
93	Smooth washer		4
94	Hex-head screw		4
95	Smooth washer		4
96	Hexagonal nut		4
97	Smooth washer		4
98	Motor plate puller		4
99	Hexagonal nut		4
100	Smooth washer		4
101	"SKF" bearing - 6010-2RS		4
103	Key - 14x10x70 mm		4
105	Circlip - E 50		4
106	Oil heating element	GM/300	7
107	Motor plate pin		4
108	Cotter pin		4
109	Hex-head screw		4
110	Smooth washer		4
111	Motor plate		4
113	Key - 8x7x50 mm	GM/80	4
114	Key 8x7x50	GM/160-300	4
115	Motor - 1,5 HP-220/380V - 50 Hz - 6P	GM/80	4
116	Motor -3 HP-220/380V-50 Hz - 6P	GM/160	4
117	Motor -4 HP-220/380V-50 Hz - 6P	GM/300	4

COMPONENT PARTS (cont'd)

Part. N°	Description		Fig.
118	Motor pulley - 80-5A	GM/80	4
119	Motor pulley	GM/80	4
121	"Vee" belt - A 43	GM/80	4
122	"Vee" belt - A 41	GM/160	4
123	"Vee" belt - A 43	GM/300	4
124	Driven pulley - 250-5A	GM/160	4
125	Driven pulley - 250-2A	GM/80	4
127	Smooth washer		4
128	Hex-head screw		4
129	Polythene gasket - O.D. : 110 mm - I.D. : 80 mm - THK. : 2 mm		4
131	Mixture pressure gauge (optional)		1
132	Oil valve vacuum gauge (optional)		1
134	Pressure switch valve - 3/8 in.	GM/80	2-7
135	Pressure switch valve - 1/2 in.	GM/160	2-7
136	Pressure switch valve - 3/4 in.	GM 300	2-7
137	Speed variator handwheel		1-6
144	Oil pressure switch		7
145	Gas pressure switch		7
146	"ALCO" thermostatic valve - Model "TCL 500H" (17.800 fg./hr. - 10/+ 25)	GM/300	2-7
147	Filter (connection : ϕ 16 mm.)		2-7
148	"ALCO" solenoid valve - Model "200 RA 4" (connection : 1/2 in.)		2-7
149	(Idem)		2-7
150	Liquid level indicator (connection : ϕ 16 mm.)		2-7
151	"DWU" refrigeration compressor - Model "D9RC750" (7,300 fg./hr. - 30/+ 30)	GM/80	2-7
152	Condenser	GM/80	2-7
153	Freezing cylinder		2-7
154	Valve - 1/4 SAE x 6		2-7
155	Two-way liquid valve - 1/4 SAE x 6		2-7
156	Hot gas flow regulating valve		1-7
157	Pressure gauge		7
158	Oil heating element		7
159	Vibration damping - ϕ 18 mm		7
160	Air valve stem		5
161	"OR" 112 gasket - I.D. : 9.92 mm - THK. : 2.62 mm		5
162	"OR" 121 gasket - I.D. : 15.88 mm - THK. : 2.62 mm		5
163	Air valve casing		5
164	Air valve front spring		5
165	Air valve adjusting ring nut		5
166	Air valve rear spring		5
167	Air valve		5
168	Rotating device - DN 21		5
169	Air valve cup		5
170	"OR" 1400 gasket - I.D. : 24.99 mm - THK. : 3.53 mm		5
173	Elbow - DN21 (male/female)		5
175	Pump casing - ϕ 18	GM/80	5
176	Pump casing - ϕ 25	GM/160	5

COMPONENT PARTS (cont'd)

Part. N°	Description		Fig.
177	Pump casing - ϕ 35 mm	GM 300	5
179	Elbow with two rotating devices - DN 21		5
180	"OR" 4137 gasket - I.D. : 34.52 - THK. : 3.52 mm		5
181	Countersunk head screw		5
182	"OR" 150 gasket - I.D. : 46.04 mm - THK. : 3.53 mm		5
183	Piston pump head - ϕ 35 mm		5
184	Rotating device - DN 40		5
185	Stainless steel ball - ϕ 10 mm (3/4 in.)		5
186	Ball thrusting spring		5
187	Spring holder outlet fitting and rotating device		5
188	Mixture inlet rubber holder - 1/2 in.	GM/80	1-5
189	Rubber holder - DN21 - 3/4 in	GM/160	1-5
190	Safety valve casing		5
191	Safety valve spring		5
192	Safety valve plug		5
193	Double junction - DN 21		5
196	Pipe - DN21		6
204	Gasket		6
206	Bracket type support covering		6
207	Screw		6
208	Washer		6
210	Single bracket type support		6
211	Hexagonal nut		6
212	Washer		6
213	Pin		6
214	Pump eccentric		6
215	Eccentric pin		6
216	Connecting rod rear cover		6
217	Round-headed screw		6
218	"SKF" bearing - 6204-2RS		6
219	Pump connecting rod		6
220	Connecting rod pin		6
221	Cotter pin		6
222	Piston	GM/80	6
223	Bracket covering		6
224	Round-headed screw		6
225	Piston - D25	GM/160	6
226	Piston - D35	GM/300	6
237	Circlip - E 20		6
238	Connecting rod lower cover		6
239	Recessed head screw		6
240	Reduction gear - "VF-70" - ratio : 1/10.33		2-6
241	Hex-head screw		6
242	Smooth washer		6
243	Reduction gear key - "VF-70" (25x5x5 mm)		6
244	Driven pulley - 148x22 mm	GM/80-160	6
245	Driven pulley - 125x22 mm	GM/300	6
246	Square washer		6
247	Pump motor plate	GM/80	6
248	Pump motor plate	GM/160-300	6
249	Motor (for pump) - 1 HP - 4 pole - 1,450 rpm. - 60 Hz	GM/80	2-6
250	Pump motor plate pin		6
251	Puller spacer		6

COMPONENT PARTS (cont'd)

Part. N°	Description		Fig.
252	Puller bush		6
253	Pump speed variator rod and articulated joint		6
254	Speed variator flange		6
255	Pump piston bushing		6
256	Condenser - HC 50	GM/160	2-7
257	Condenser - HC 250 B	GM/300	2-7
258	Vibration damping (see pipe ϕ)		7
259	Countersunk-head screw		6
261	Variable driving pulley - ϕ 125x19 mm (for HP/4 pole motor)	GM/160-300	6
262	Variable driving pulley - ϕ 125x14	GM/80	6
263	Belt - 22x8x700 mm	GM/160-300	2-6
264	Belt - 22x8x750 mm	GM/80	2-6
266	"VF-70" reduction gear key (44x8 mm)		6
267	Safety plug		2
268	Motorized compressor oil plug		2
271	Pin		4
273	Compressor oil level		2
274	Recessed head screw - 10x30 mm		6
275	Washer		6
276	Nut - ϕ 10 mm		6
277	Washer		6
278	Nut		6
279	Nut		6
281	"ALCO" thermostatic valve - Model TC.LE. 200 HW	GM/160	2-7
282	"ALCO" thermostatic valve - Model TC.LE. 100 HW	GM/80	2-7
283	Motor (for pump) - 1 HP - 220/380V 50Hz - 4P	GM/160-300	6

FIG. 1

LEGEND

- 1) Control panel housing
- 2) Safety valve
- 5) Ice-cream outflow pipe
- 6) Adjusting screw
- 8) Dasher shaft switch
- 9) Mixture pump switch
- 10) Ammeter
- 11) Vacuum gauge
- 12) Base supporting foot
- 13) Hot gas valve switch
- 14) Refrigeration compressor switch
- 16) Mixture pump
- 18) Mixture inlet pipe end fitting
- 19) Mixture pipeline
- 20) Compressor thermic resetting pushbutton
- 21) Dasher shaft thermic resetting pushbutton
- 22) Pump thermic resetting pushbutton
- 60) Ice-cream outlet upper flange
- 133) Mixture pump pressure gauge (optional)
- 134) Oil valve vacuum gauge (optional)
- 137) Pump speed variator handwheel
- 156) Hot gas flow regulating valve
- 165) Air valve adjusting ring nut
- 167) Air valve
- 189) Mixture inlet rubber holder

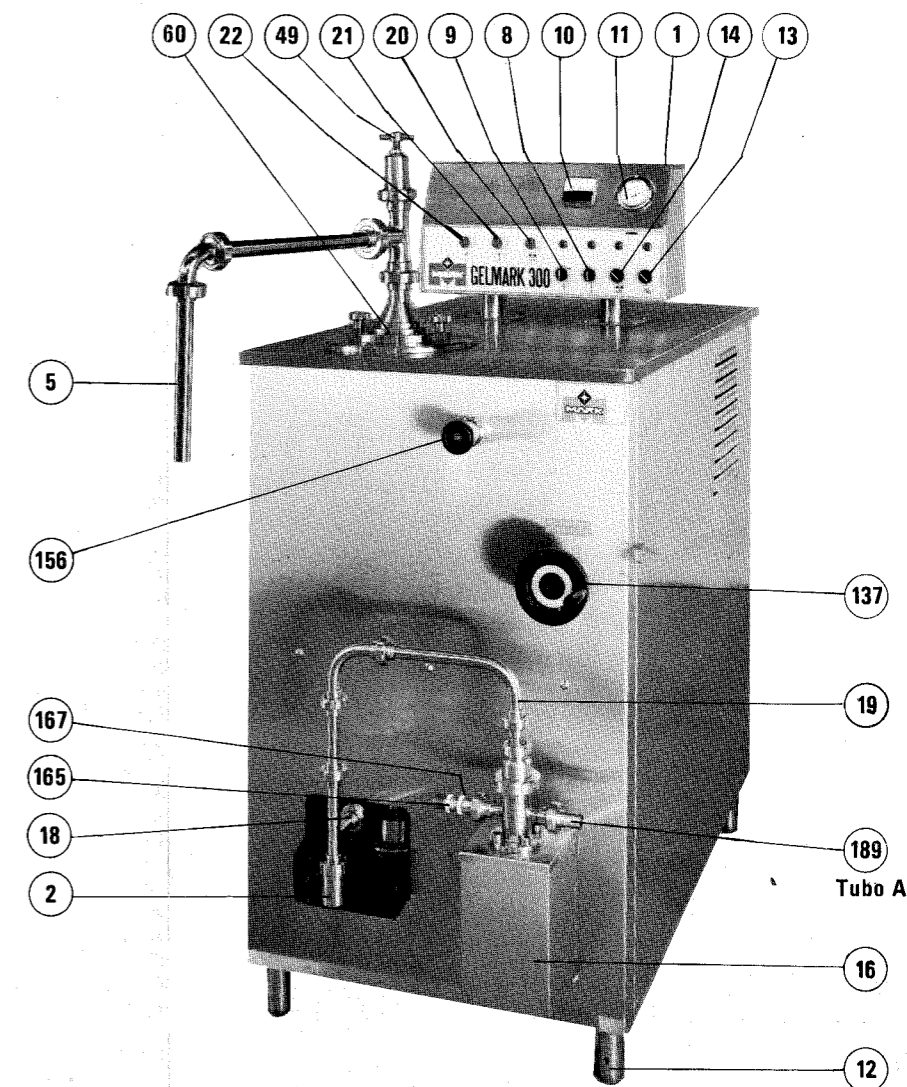
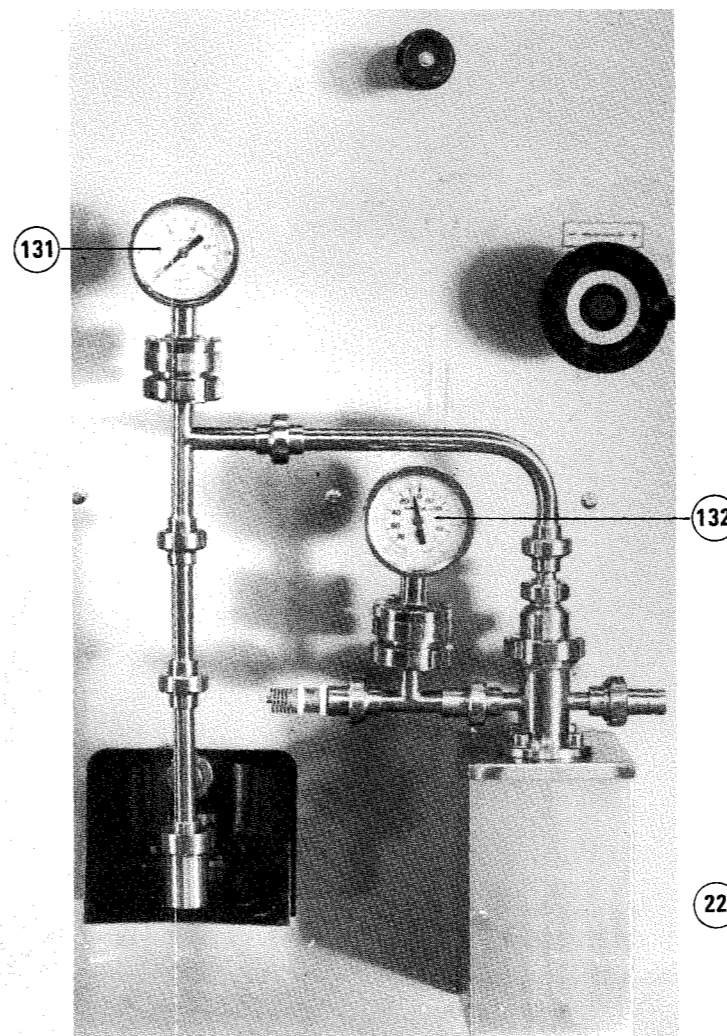

FIG. 1

FIG. 2

LEGEND

- 6) Freezing cylinder
- 115) Shaft motor
- 121) "Vee" belt(s)
- 124) Driven pulley
- 136) Pressure switch valve
- 145) Gas pressure switch
- 146) Thermostatic valve
- 147) Circuit filter
- 148) Hot gas solenoid valve
- 149) Liquid flow closure solenoid valve
- 150) Liquid passage sight gauge
- 151) Refrigeration motorized compressor
- 152) Liquid receiving condenser
- 154) Hot gas line valve
- 155) Vacuum gauge interception valve
- 240) Pump reduction gear
- 247) Variable pulley for pump speed variator
- 249) Pump motor
- 263) Speed variator belt
- 267) Safety plug
- 268) Motorized compressor oil plug
- 273) Compressor oil level

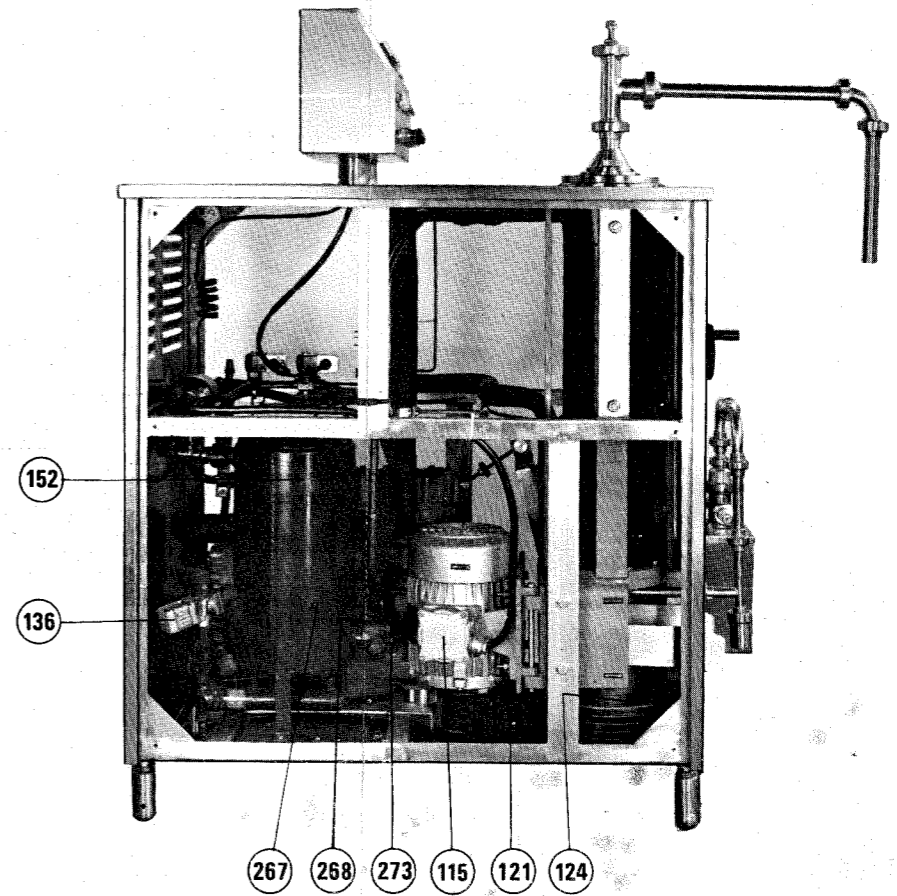
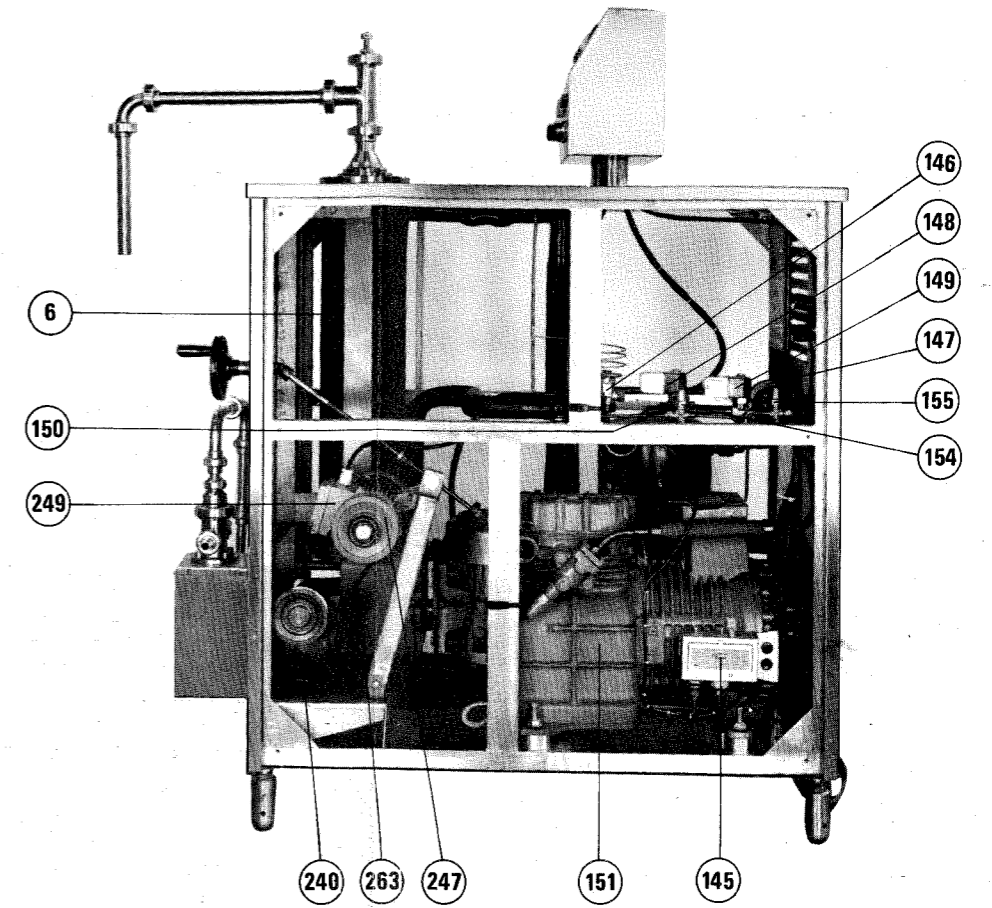
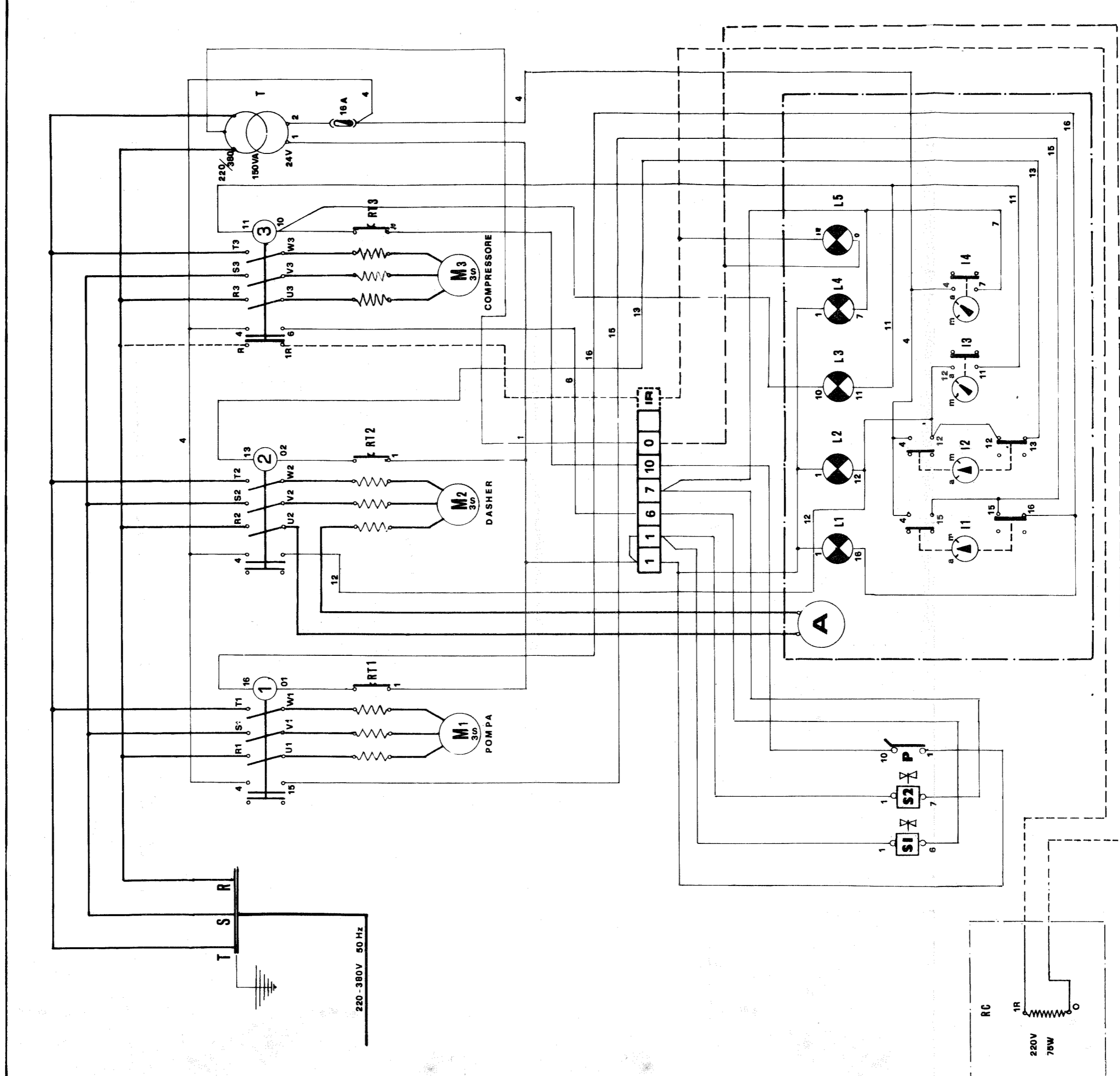

FIG. 2



	220 V	380 V
RT 1	2.7 ÷ 4 A	1.8 ÷ 2.7 A
RT 2	8 ÷ 12 A	5.4 ÷ 6 A
RT 3	11 ÷ 17 A	5.5 ÷ 8 A

GM 160

	220 V	380 V
RT 1	1.8 ÷ 2.7 A	
RT 2	4 ÷ 6 A	2.7 ÷ 4 A
RT 3	5.5 ÷ 8 A	2.7 ÷ 4 A

GM 80

FIG. 8

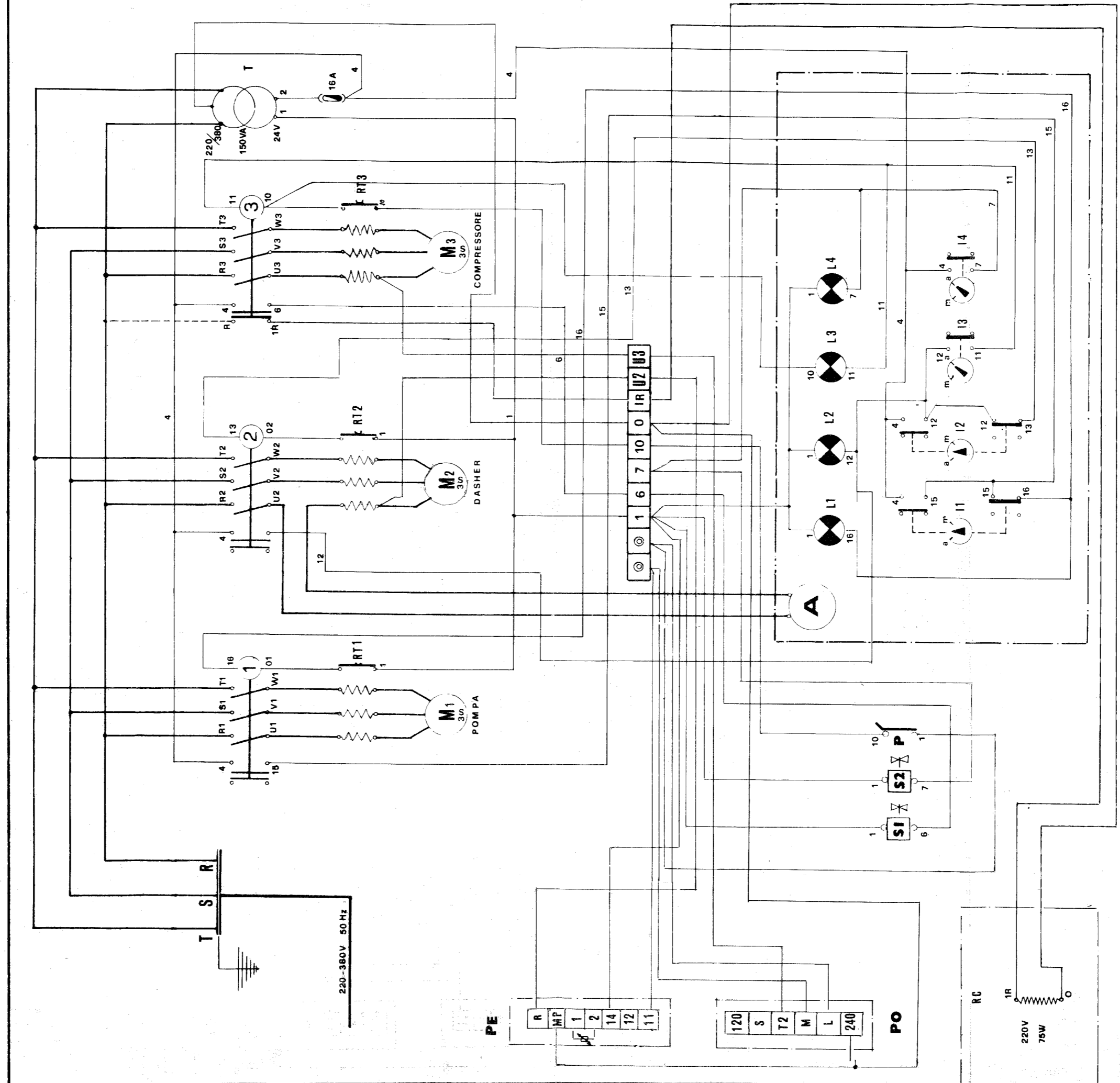

LEGEND

- 1. Mixture pump switch
- 2. Dasher shaft switch
- 3. Frigorific compressor switch
- RT Overload thermal relay
- T Transformer
- A Ammeter
- L1 Pump signal lamp
- L2 Dasher signal lamp
- L3 Motocompressor signal lamp
- L4 Hot gas signal lamp
- 11 Pump switch
- 12 Dasher switch
- 13 Compressor switch
- 14 Hot gas switch
- P Pressure switch
- PE Compressor electronic protection
- PO Compressor oil pressure switch
- S1 Compressor solenoid valve
- S2 Hot gas solenoid valve
- RC Compressor oil heating element

GM 300

	220V	380V
RT 1	2,7 ÷ 4A	1,8 ÷ 2,7A
RT 2	11 ÷ 16,5A	8 ÷ 12A
RT 3	15 ÷ 23A	11 ÷ 16,5A

FIG. 9