

Technohoy

CARL HOYER A/S

TECHNICAL DOCUMENTATION

MF-50

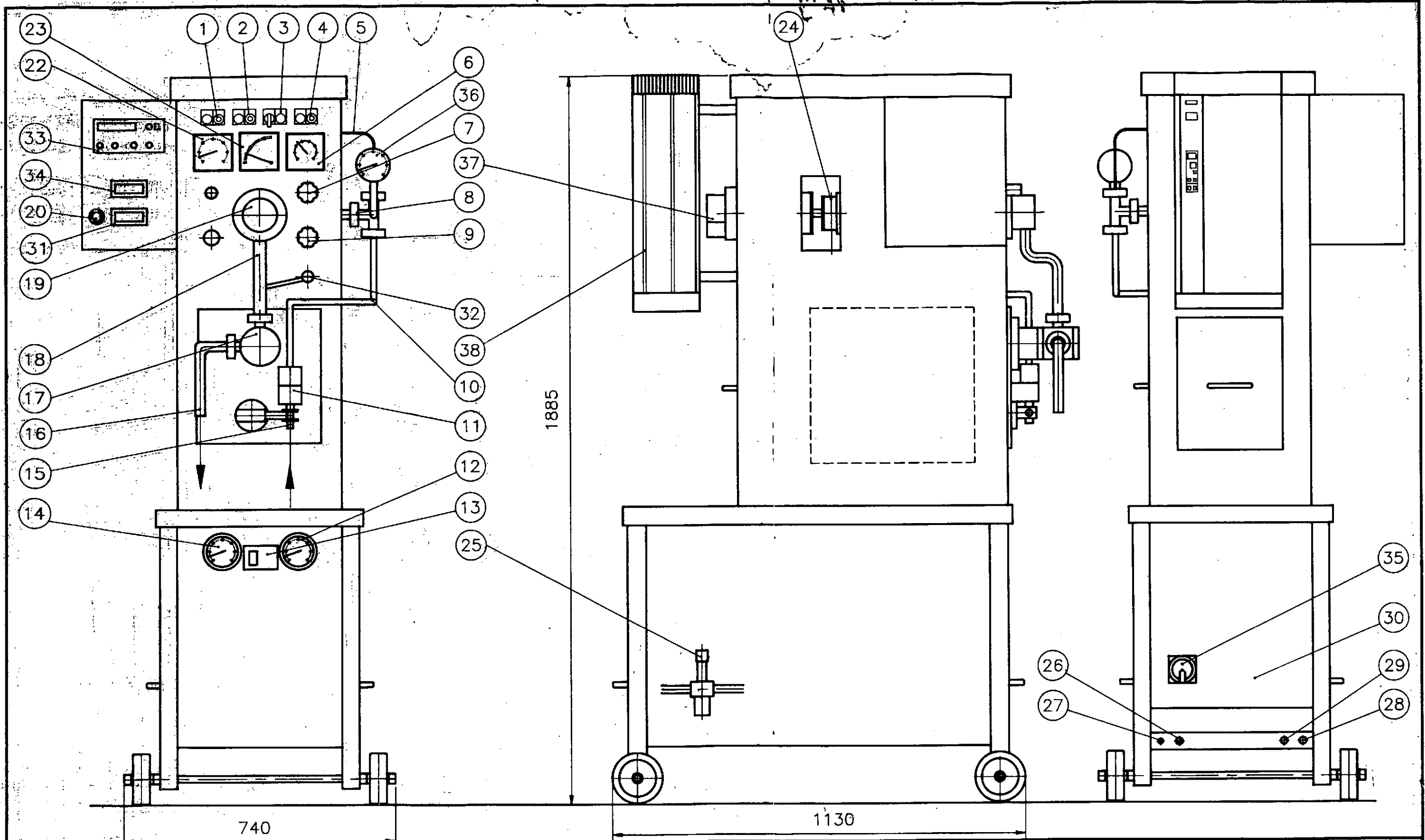

Afkortningsmål:		TECHNOHOY CARL HOYER A/S AARHUS - DENMARK	Skala	Tegn.	JA
Antal	Dimension		Dato	30.10.90	
		MF 50	C 10813		
			C 16440		
		Materiale	Maskintype MF		

FREEZER TECHNOLOGY MF50.

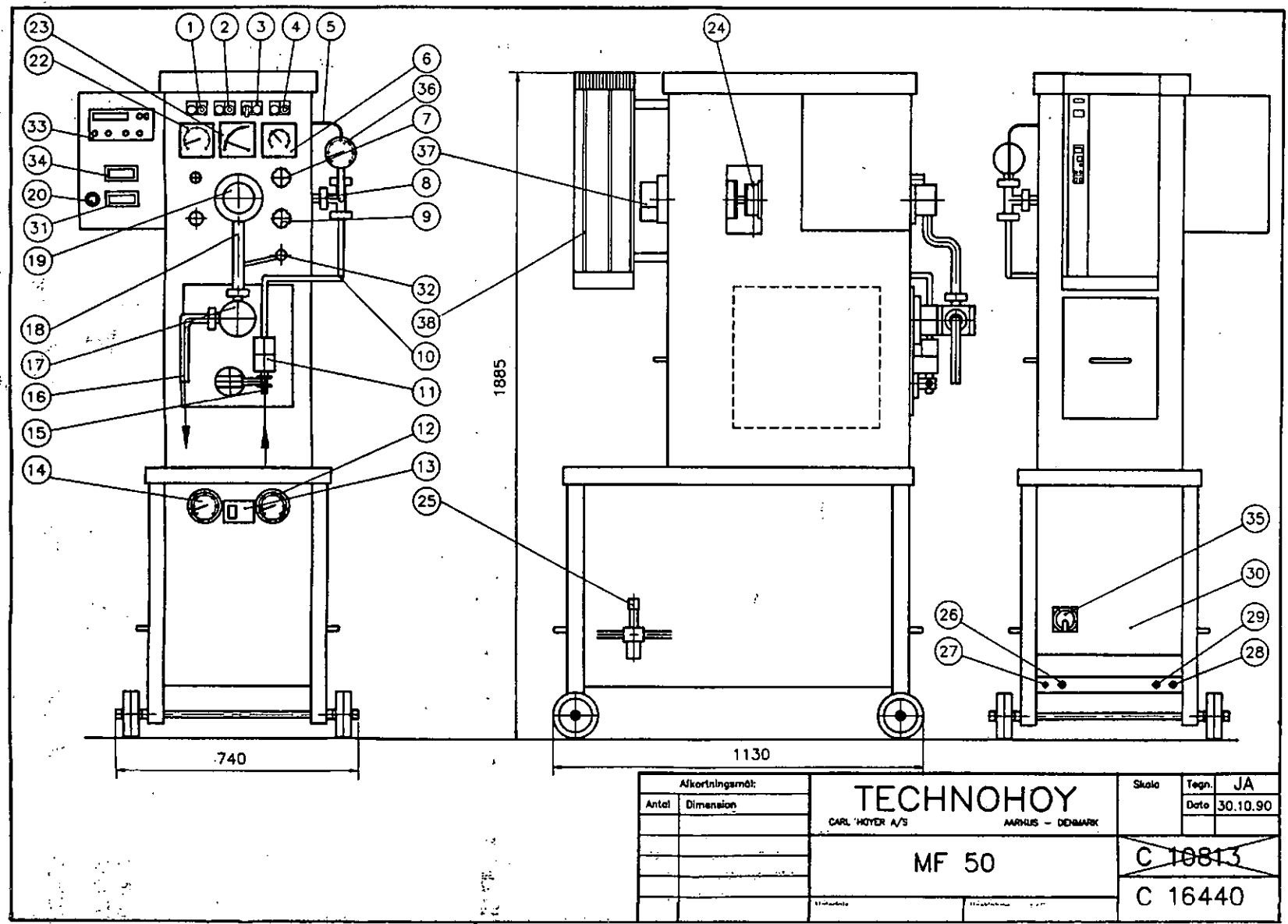

Alkortningsmåt:		TECHNOHOY CARL HOYER A/S AARHUS - DENMARK	Skala	Tegn.	JA
Antal	Dimension		Date	30.10.90	
		MF 50	C 10813		
			C 16440		

LIBELLE: *Vue d'ensemble*

FAMILLE: 57 09

SOUS FAMILLE: A

SCHEMA

N° PLAN:

31-MAR-93 01:11 PM

EUROPEAN MAINTENANCE SYSTEM
SYSTEME DE GESTION DU MATERIEL

CONSULTATI
COMPTE

OPTION

==> INTERROGATION PAR FAMILLE = 5710 Freezer Technohoy LABO PILOT - Moto
NUMERO STOCK
ARTICLE DESCRIPTION DE L'ARTICLE LOCAL. REEL
07-05-035 COURROIE TRAPEZ. SPZ 1437 10X08 GATES 4-4.6 3
30-37-001 *MOT. ABB MT100LA28-4 2,20KW 0

UTILISER LES FLECHES, [FENET_SUITE] [FENET_PREC], [PLUS_DETAIL], [ALARM] OU [SAUV
UTILISER [CHANGE_MODE] POUR LE MODE EDITION

Rep..	Courroie	0705 035 .
Rep 35	Joint	57M004
Rep 34	Joint à terre	02.02.....
Rep 36	Joint à terre	02.02....
Rep 11	Roulement	01..
Rep 15	Roulement	01....

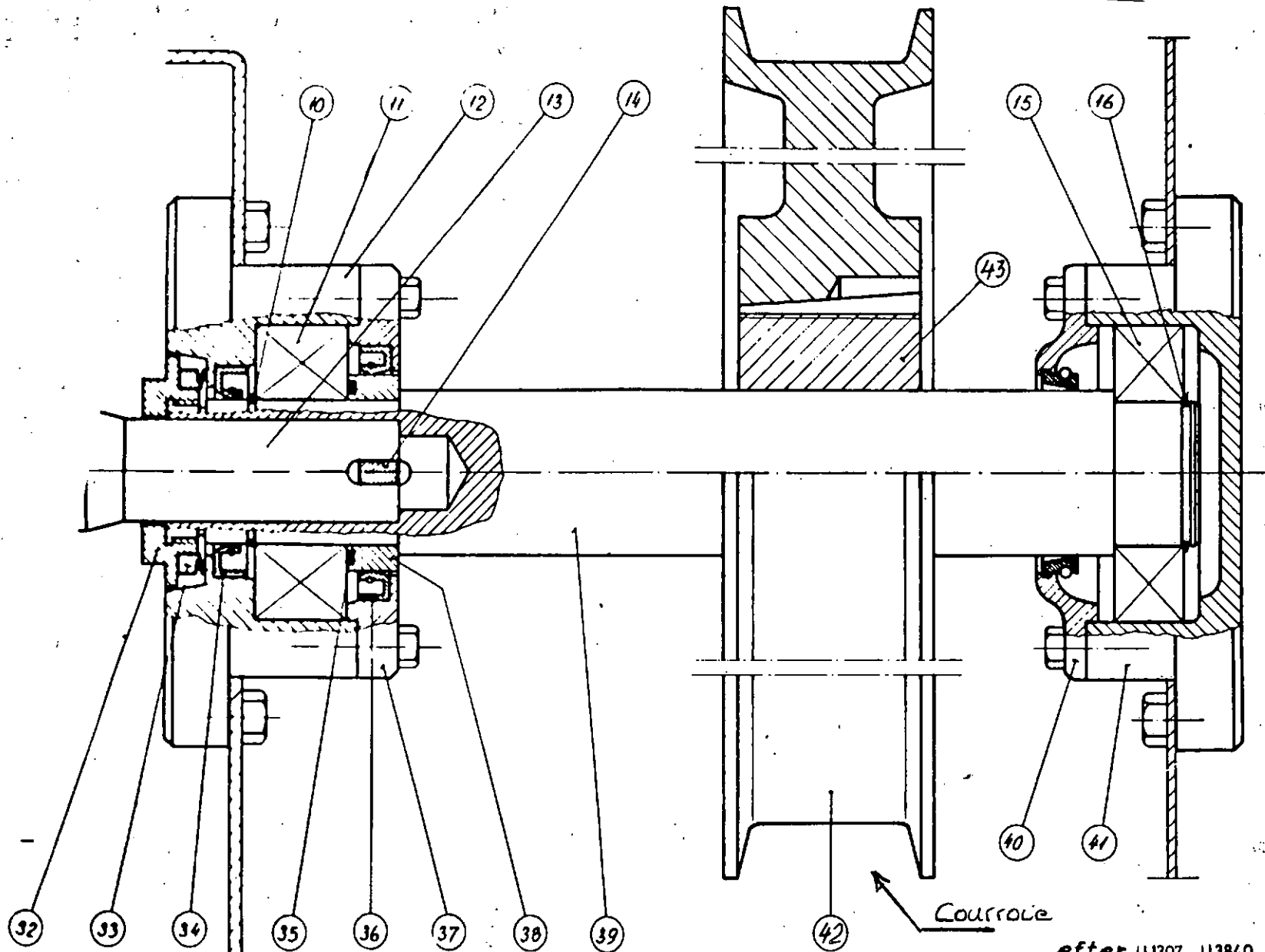

Technopol CIVILINGENIØR OG HØYER AARHUS · DANMARK	Mål:	Tegn. 30.10.79
	1:1	Maskine type. MF 50
erstatter U 1307		U 5437

Frysecylinder med hovedtræk

FAMILLE	57	SOUS FAMILLE	11	SCHEMA	A.
LIBELL: Entrainement robot				N° PLAN:	
ORIGINE:					

OPTION

==> INTERROGATION PAR FAMILLE = 5711 Freezer Technohoy LABO PILOT - Entr

NUMERO	ARTICLE	DESCRIPTION DE L'ARTICLE	LOCAL.	STOCK REEL
57-11-004	JOINT	PLAN U 5437	REP.35A NPDS	0
57-11-002	JOINT A LEVRE	PLAN U 5437	REP.34A NPDS	0
57-11-005	JOINT A LEVRE	PLAN U 5437	REP.36A NPDS	0
57-11-001	PIECE	PLAN U 5437	REP.33A NPDS	0
57-11-003	ROULEMENT	PLAN U 5437	REP.11A NPDS	0
57-11-006	ROULEMENT	PLAN U 5437	REP.15 NPDS	0
07-05-035	COURROIE TRAPEZ. SPZ 1437	10X08 GATES	4-4.6	3
06-01-003	*CHAINE SIMPLE P 9,525	06 B-1 ACIER IWIS	ADK	22

UTILISER LES FLECHES, [FENET_SUITE] [FENET_PREC], [PLUS_DETAIL], [ALARM] OU [SAUV
UTILISER [CHANGE_MODE] POUR LE MODE EDITION

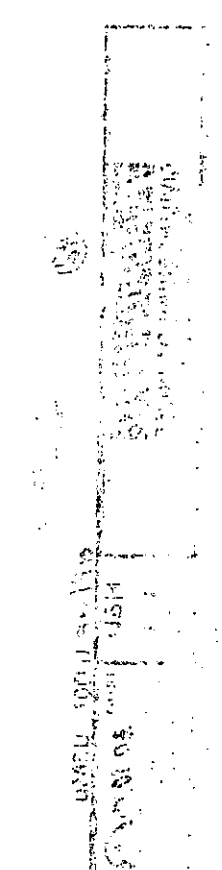

[Handwritten signature or mark]

Rep.

chaîne Pas 9,5h

0601003.

31-MAR-93 01:13 PM

EUROPEAN MAINTENANCE SYSTEM
SYSTEME DE GESTION DU MATERIEL

CONSULTATI
COMPTE

OPTION

==> INTERROGATION PAR FAMILLE = 5712 Freezer Technohoy LABO PILOT - Syst
NUMERO STOCK
ARTICLE DESCRIPTION DE L'ARTICLE LOCAL. REEL
57-12-002 ENGRENAGE + PIGNON PLAN C 2954 REP.7A 0
57-12-001 ENGRENAGE CONIQUE PLAN C 2954 REP.13A 0
06-01-003 *CHAINE SIMPLE P 9,525 06 B-1 ACIER IWIS ADK 22

UTILISER LES FLECHES, [FENET SUITE] [FENET PREC], [PLUS_DETAIL], [ALARM] OU [SAUV
UTILISER [CHANGE_MODE] POUR LE MODE EDITION

Handwritten notes and a stamp in the bottom right corner, including the word "MATERIEL" and some illegible markings.

31-MAR-93 01:13 PM

EUROPEAN MAINTENANCE SYSTEM
SYSTEME DE GESTION DU MATERIEL

CONSULTATI
COMPTE

OPTION

==> INTERROGATION PAR FAMILLE = 5713 Freezer Technohoy LABO PILOT - Cyl
NUMERO STOCK
ARTICLE DESCRIPTION DE L'ARTICLE LOCAL. REEL
57-13-003 GARNITURE COMPLETE PLAN U 5437 REP.9A NPDS 0
57-13-004 JOINT TORIQUE PLAN U 5437 REP.5/28 NPDS 0
57-13-001 PALIER GUIDAGE PLAN U 5437 REP.21A NPDS 1
57-13-002 *COUTEAUX DE RACLAGE PLAN U 5437 REP.22A NPDS 2
02-01-140 JOINT TORIQUE 24,50X3,50 NITRILE 097091 6
02-01-142 JOINT TORIQUE 79,50X3,00 EPDM NP 0

UTILISER LES FLECHES, [FENET_SUITE] [FENET_PREC], [PLUS_DETAIL], [ALARM] OU [SAUV
UTILISER [CHANGE_MODE] POUR LE MODE EDITION

Handwritten signature

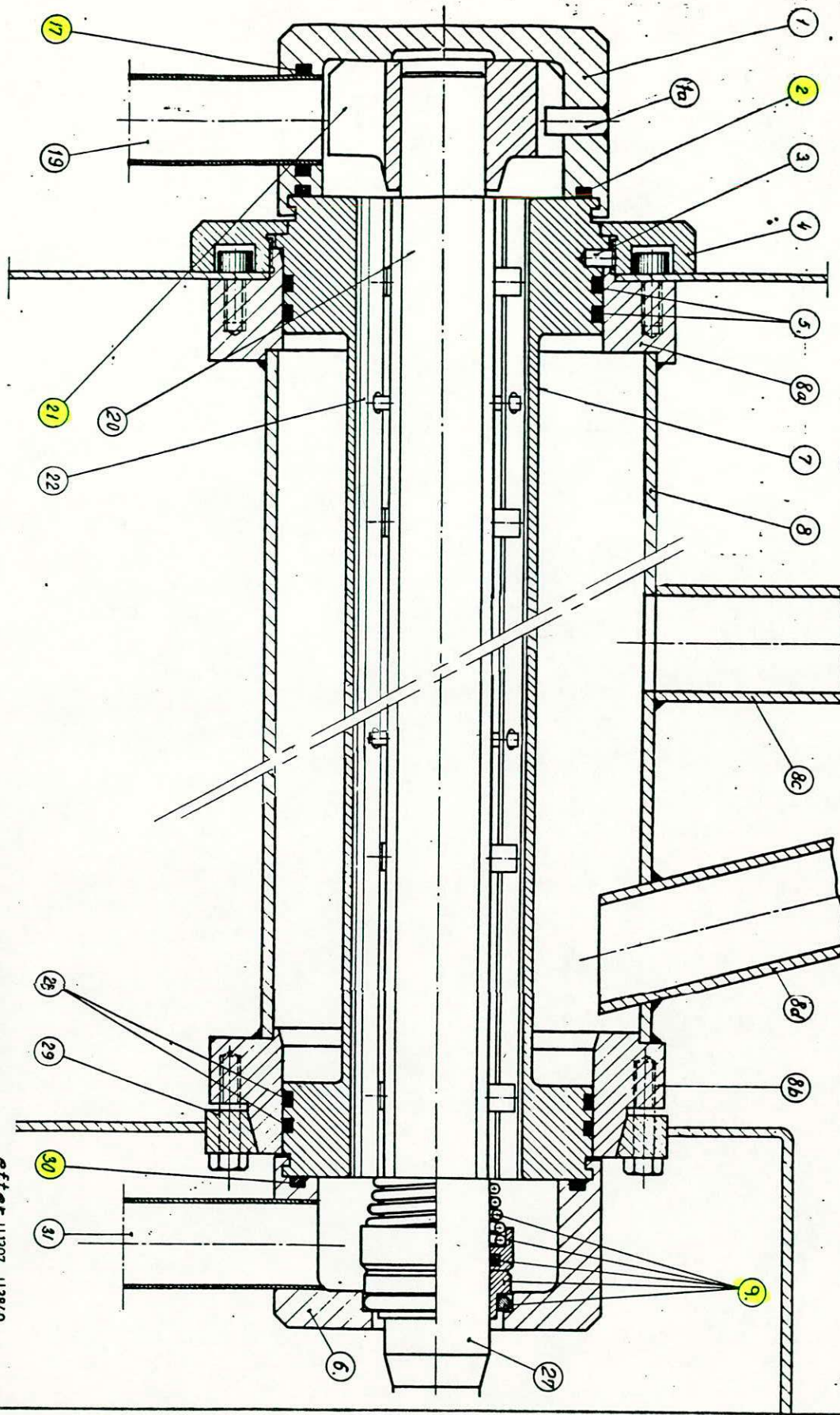

Technohoy
 CIVILINGENIØR OG HØYER
 ÅRHUS · DANMARK

efter U 1307 U 3840
 Mål: Tegning 30.10 mg
 1:1 Høkkeringstype MF 50
 erstatter U 1307 U 5437

Frysacylinder med hovedtrek

LIBELLE:	FAMILLE	SOUS FAMILLE	SCHEMA
Cylindre 1. Bøjer	57	13	A.
ORIGINE:	N° PLAN:		

Rep 2/30

Rep 17

Joint torique 79,5x3

Joint torique 24x3,5

0201142

0201140

Rep -

Manomètre

2874017.

firma: **TechnoHoy**
 CIVILINGENIØR D.G.HØYER
 AARHUS - DANMARK

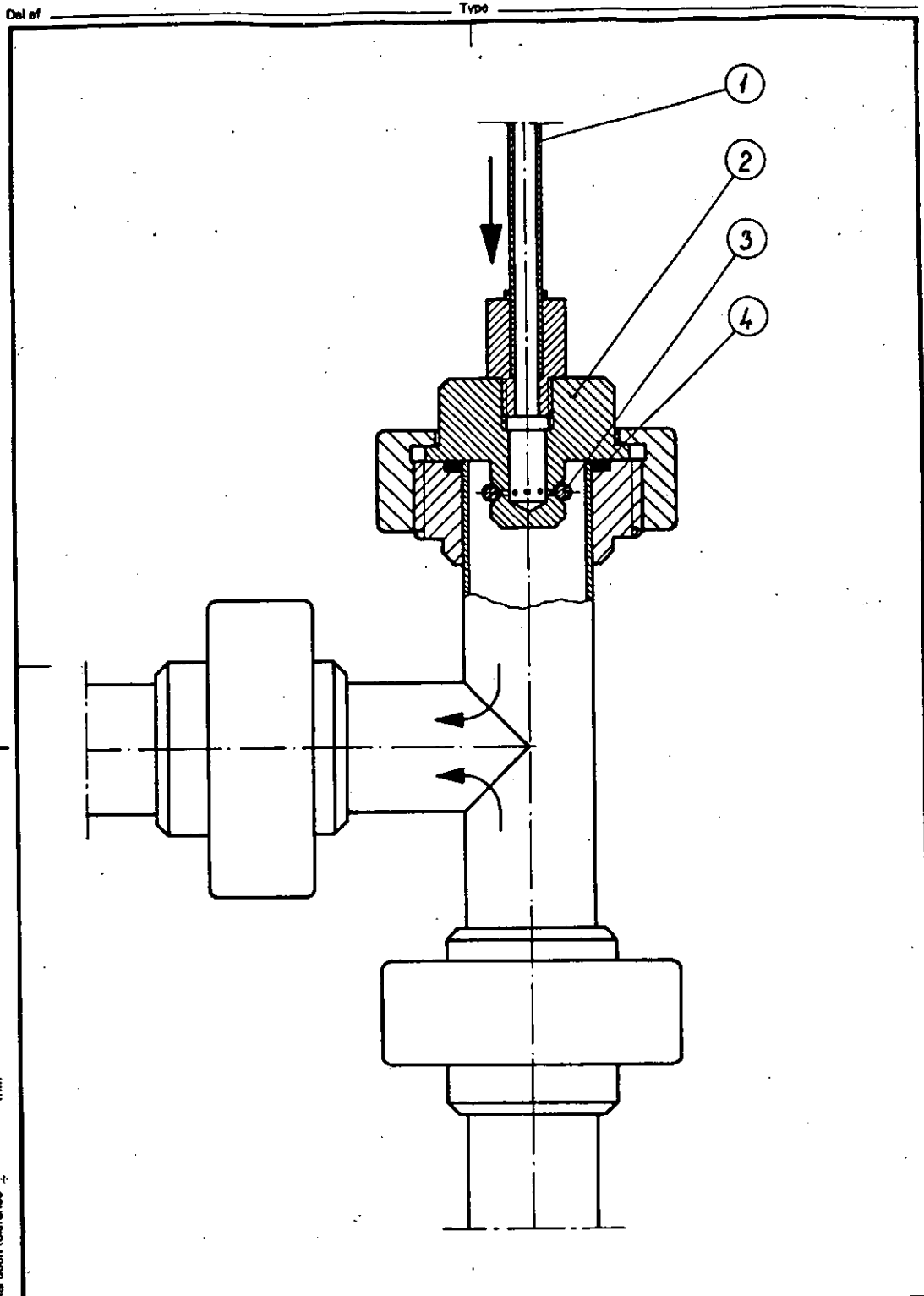

Alle mål uden tolerance ±
 mm

	Materiale	Model nr.	Lager nr.	Måstørhold	Tegn.	78.06.15.
				1:1	Kont.	R
Genstand:				Tg. nr. D 3141		
T-stykke m/kontraventil						

HM 1091 16 27 27

LIBELLE:	Système de forsonnement.		
	FAMILLE	SOUS FAMILLE	SCHEMA
ORIGINE:	57	15	A.
N° PLAN:			

31-MAR-93 01:14 PM

EUROPEAN MAINTENANCE SYSTEM
SYSTEME DE GESTION DU MATERIEL

CONSULTATI
COMPTE

OPTION

==> INTERROGATION PAR FAMILLE = 5715 Freezer Technohoy LABO PILOT - Syst

NUMERO	ARTICLE	DESCRIPTION DE L'ARTICLE	LOCAL.	STOCK REEL
57-15-001	DIFFUSEUR D'AIR	PLAN D 3141 REP.2A	NPDS	0
57-15-002	JOINT TORIQUE	PLAN D 3141 REP.3A	NPDS	0
02-11-006	JOINT DE CLAMP DN 51	EPDM 9611-99-1360	139131	84
02-10-002	JOINT DE RACCORD SMS DN25	EPDM 31317-0375-3	138181	55
02-12-001	JOINT DIN DN-20 23X33X4	PERBUNAN	141251	75
02-12-005	JOINT DIN DN-25 30X40X5	PERBUNAN	NP	10
23-74-017	MANOMETRE D106 RACCORD TRICLAMP 0-16BARS		044011	3
-	-			
-	-			
-	-			
-	-			
-	-			
-	-			
-	-			
-	-			
-	-			

UTILISER LES FLECHES, [FENET_SUITE] [FENET_PREC], [PLUS_DETAIL], [ALARM] OU [SAUV
UTILISER [CHANGE_MODE] POUR LE MODE EDITION

[Handwritten signature]

31-MAR-93 01:13 PM

EUROPEAN MAINTENANCE SYSTEM
SYSTEME DE GESTION DU MATERIEL

CONSULTATI
COMPTE

OPTION

===> INTERROGATION PAR FAMILLE = 5714 Freezer Technohoy LABO PILOT - Pomp
NUMERO STOCK
ARTICLE DESCRIPTION DE L'ARTICLE LOCAL. REEL
44-21-001 POMPE HOYER FP1 0
44-22-001 POMPE HOYER TECHNOHOY 0
- -
- -
- -
- -
- -
- -
- -
- -
- -
- -

UTILISER LES FLECHES, [FENET_SUITE] [FENET_PREC], [PLUS_DETAIL], [ALARM] OU [SAUV
UTILISER [CHANGE_MODE] POUR LE MODE EDITION

POMPES

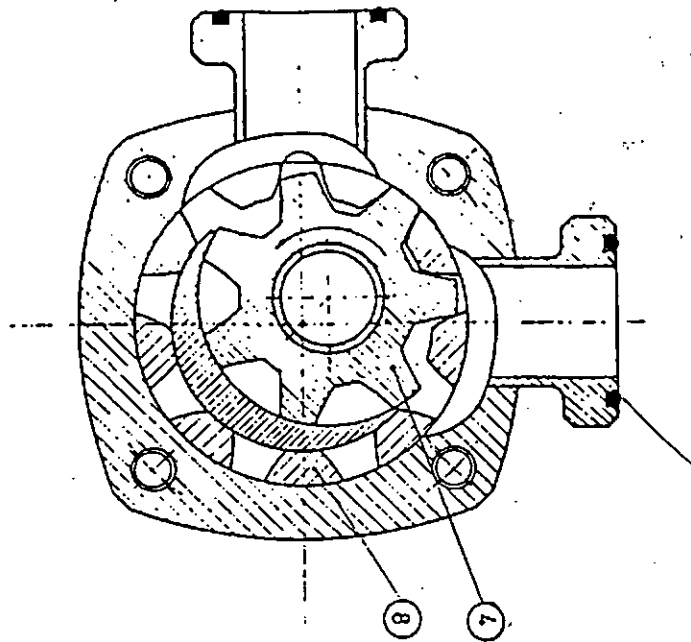

Snit A-A

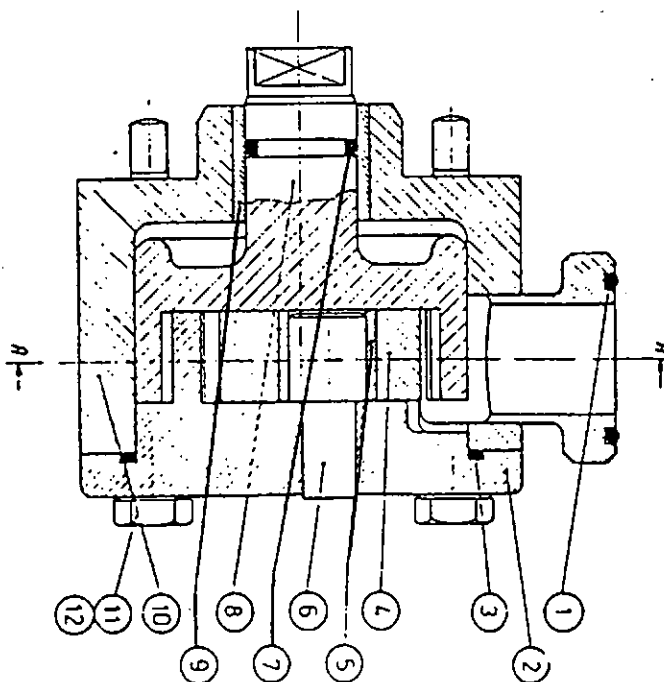

Technohoy
 CARL HOYER AS
 Axel Kiess Vej 30
 DK-8270 Århus - Høbjerg

LIBELLE:	FAMILLE	SOUS FAMILLE	SCHEMA
POMPE HOYER FP 1	44	21	A.
ORIGINE: Freezer-TECHNOHOY.	N° PLAN:		

Rep 1 Joint Dir

0212005

31-MAR-93 01:14 PM

EUROPEAN MAINTENANCE SYSTEM
SYSTEME DE GESTION DU MATERIEL

CONSULTATI
COMPTE

OPTION

==> INTERROGATION PAR FAMILLE = 4422 HOYER Technohoy

NUMERO	ARTICLE	DESCRIPTION DE L'ARTICLE	LOCAL.	STOCK REEL
44-22-001	POMPE HOYER TECHNOHOY			0
44-99-048	BAGUE DE GUIDAGE	PLAN D 9406	REP.31A NPDS	0
44-99-051	BILLE INOX DIA.10	PLAN D 9406	REP.8A NPDS	1
44-99-047	GALET DE TRANSMISSION	PLAN D 9406	REP.15A NPDS	2
02-01-139	JOINT TORIQUE 19,50X3,00	EPDM	NP	2
02-01-141	JOINT TORIQUE 29,50X3,00	EPDM	NP	5
44-99-049	PISTON COMPLET	PLAN D 9406	REP.17A NPDS	1
44-99-050	SIEGE CLAPET	PLAN D 9406	REP.7A NPDS	2

UTILISER LES FLECHES, [FENET_SUITE] [FENET_PREC], [PLUS_DETAIL], [ALARM] OU [SAUV
UTILISER [CHANGE_MODE] POUR LE MODE EDITION

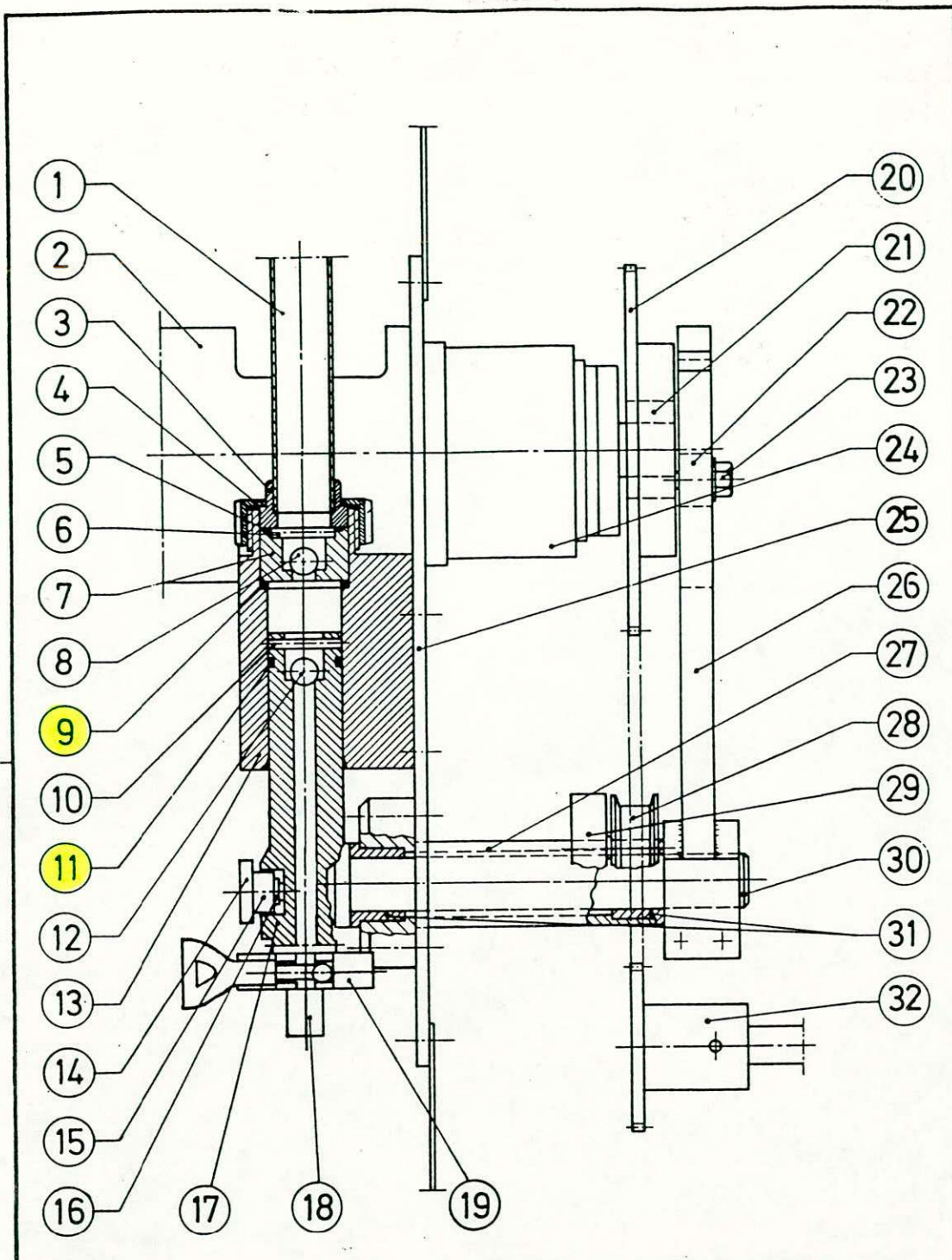

Tolerancer, der ikke angives ved spåntegende bearbejdn. stigning eller stansning		Målestok 1:2,5	TECHNOHOY		Dato 13.01.87.
		First angle projection ISO method E	AARHUS	DENMARK	Tegn: S.K.
			Driving arrangements for pumps Antrieb für Pumpen		Godk:
Basismål	Tol				
(1)	6 ±0.1				
(6)	30 ±0.2				
(30)	120 ±0.3				
(120)	315 ±0.5				
(315)	1000 ±0.8	T. Kort	Rett.		
(1000)	2000 ±1.2	Materiale	Rett.		
(2000)	4000 ±2.0	Maskinlyse MF	Rett.		

H. M. (09) 1627 27

LIBELLE:	POMPE HOYER TECHNOHOY.	FAMILLE	SOUS FAMILLE	SCHEMA
		44	22	A.
ORIGINE:	Greener TECHNOHOY.	N° PLAN:		

Rep 11

Joint torque

0201 139

Rep 9

Joint torque

0201 141

Expéditeur : DOVEUROPE route de Saverne B.P. 3
67790 STEINBOURG

Destinataire : _____

LOCATION FREEZER MF100

POUR RUN TWIX

Poids brut : _____

Poids net : _____

**FØLGESEDDER
DELIVERY NOTE**

Technohoy
CARL HOYER A/S

Axel Kiers Vej 30
DK-8270 Aarhus - Højbjerg

Phone national 86 29 21 88
Phone internat. + 45 86 29 21 88
Telefax + 45 86 29 27 80
Carl Hoyer private + 45 86 27 04 45
A/S reg. nr. 65240
Bankers: Den Danske Bank
S.W.I.F.T. Address:
DABA DK KK 4620135909
Postal Account 8 17 12 38

DOVEUROPE S. A.
Route de Saverne
F-67790 Steinbourg

Yourref.: Mr. Eric Hoenen Ourref.: Mrs. G. Simonsen Date: 02.10.92
C1469

TNT fragtbrev 92 64 15 405
1 colli 37x29x5 cm Kg 0,500

Spare parts for MF 100

1 pcs. Bearing D 1941,21
2 pcs. Stuffing box
4 pcs. O-ring
8 pcs. O-ring
8 pcs. O-ring
10 pcs. O-ring
2 pcs. Kugle

- Attention facturation de toutes les pieces
- Remboursement à Teck.

FAX TRANSMISSION**Technohoy**

CARL HOYER A/S

Axel Kiers Vej 28-30
DK-8270 Aarhus-Højbjerg
DENMARK
A/S reg. nr. 201200
Telefax +45 86 29 27 80

YOUR FAX NO:	009 33 8871 1830
NO OF PAGES INCL. THIS ONE:	1
DATE:	09.11.92
TO COMPANY:	Doveurope
ATT.:	M. Olivier Clechet → EH
FROM:	Carl Hoyer
PLEASE CALL US AT +45 86 29 21 88 IF TRANSMISSION IS RECEIVED INCOMPLETE	

Dear Mr Clechat,

Re: MF100 freezer

Thank you for your telephone call this morning.

Please be informed that above freezer will be picked up by the forwarding agents of Danzas, Strassbourg, tomorrow, Tuesday 10 November 1992. The contact person at Danzas is Miss Mattern.

The freezer is to be shipped to Germany, not Denmark.

As per our telefax dated 5 November 1992 to Mme Lagarde, the free must be placed in a wooden box standing on a pallet in order for a fork truck to handle the freezer.

Yours sincerely,

TECHNOHOY CARL HOYER A/S

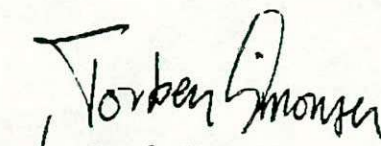
Carl Hoyer

FAX TRANSMISSION**Technohoy**

CARL HOYER A/S

Axel Kiær Vej 28-30
DK-8270 Aarhus-Højbjerg
DENMARK
A/S reg. nr. 201200
Telefax +45 86 29 27 80

YOUR FAX NO: 33 8871 1830

NO OF PAGES INCL. THIS ONE: 1

DATE: 05.11.92

TO COMPANY: Doveurope

ATT.: Mme Lagarde

FROM: Mr Simonsen

PLEASE CALL US AT +45 86 29 21 88 IF TRANSMISSION IS RECEIVED INCOMPLETE

Dear Mme Lagarde,

Re: MF 100 freezer

Thank you for the telephone conversation this morning. As agreed, the freezer will be picked up this coming Tuesday 10 November 1992 by the forwarding agent, Danzas of Strasbourg. Please remember to deliver the Carnet, i.e. the paper for customs clearance, to the agent. Thank you.

Regarding the shipping box in which we dispatched the freezer to you, and which is needed for returning the freezer, in case this box is missing, please see to the following:

Doveurope must, ahead of 10 November 1992, manufacture a new shipping box. In this respect it is necessary to note that the freezer must be placed on a pallet in order that a fork truck can handle the freezer. Once the freezer is situated on the pallet you can start building the box, i.e. the sides and the top. Finally, it is important that the freezer is standing upright, i.e. it must never be put on its side.

Since Doveurope has not been invoiced the manufacturing of the shipping box built by Technohoy it follows that all costs arising from the manufacturing of a new shipping box are to be borne by Doveurope.

Yours sincerely,

TECHNOHOY CARL HOYER A/S

Torben Simonsen

FAX TRANSMISSION**Technohoy**

YOUR FAX NO:	009 33 88 71 18 30	CARL HOYER A/S Axel Kiers Vej 30 DK-8270 Aarhus-Højbjerg D E N M A R K TELEFAX +45 86 29 27 80
NO. OF PAGES INCLUDING THIS ONE:	1	
DATE:	02.10.92	
TO COMPANY:	Doveurope	
ATT.:	Mr. Eric Hoenen	
FROM:	Mrs. Gitte Simonsen	
PLEASE CALL US AT +45 86 29 21 88 IF TRANSMISSION IS RECEIVED INCOMPLETE		

Dear Mr. Hoenen

Referring to our telephone conversation Wednesday I can inform you that the bearing and the O-rings you need for the MF100, you have rented, are shipped from Technohoy today, so that you have the parts Monday.

I also ship some extra spare parts as promised in my telefax of the 29.09.92 to Mrs. Lagarde.

Unfortunately we do not have any knives in stock, but if you need some new ones, please let me know. Then we will produce some.

Best regards,

TECHNOHOY CARL HOYER A/S

Gitte Simonsen

Gitte Simonsen

FAX TRANSMISSION**Technohoy**

YOUR FAX NO:	009 33 88 71 18 30
NO. OF PAGES INCLUDING THIS ONE:	1
DATE:	29.09.92
TO COMPANY:	Doveurope
ATT.:	Mrs. D. Lagarde
FROM:	Mrs. G. Simonsen
PLEASE CALL US AT +45 86 29 21 88 IF TRANSMISSION IS RECEIVED INCOMPLETE	

CARL HOYER A/S
Axel Kiær Vej 30
DK-8270 Aarhus-Højbjerg
D E N M A R K
TELEFAX +45 86 29 27 80

Dear Mrs. Lagarde,

According to your agreement with our Mr. Carl Hoyer, we shall as soon as possible forward you a complete set of spare parts for the MF 100 freezer, which you have rented.

You will receive an invoice for these spare parts. However, at time of expiry of the rent agreement you may return the parts not used, and you will be credited accordingly.

Yours sincerely,

TECHNOHOY CARL HOYER A/S

Gitte Simonsen

Gitte Simonsen

Technohoy product description

April 1990..	MF 50	MF 75	MF 100	MF 100 L	MF 200	MF 300
TECHNICAL DATA for standard models	Laboratory freezer	Spec. production f.limited output	Production freezer	Production freezer	Production freezer	Production freezer
Nominal output	20 - 100	30 - 160	60 - 300	84 - 420	100 - 550	150 - 650
Imp. Gall	4.5 - 22	7 - 35	13 - 66	19 - 92	22 - 121	33 - 154
U.S. Gall	5.5 - 27	8 - 42	16 - 79	22 - 111	27 - 145	40 - 185
Evap./condensing temperature	-25 / + 40	-25 / + 40	-25 / + 40	-25 / + 40	-25 / + 40	-25 / + 40
°C	-25 / + 40	-25 / + 40	-25 / + 40	-25 / + 40	-25 / + 40	-25 / + 40
°F	-13 / + 104	-13 / + 104	-13 / + 104	-13 / + 104	-13 / + 104	-13 / + 104
Refrigerating effect	6000	10700	13440	16000	16000	20600
W	6000	10700	13440	16000	16000	20600
kcal/h	5160	9202	11558	13760	13760	17700
Surface freezing tube	628	942	1885	2639	3769	4882
cm ²	628	942	1885	2639	3769	4882
Compressor motor	2.2	5.5	7.5	9.2	9.2	11.0
kW	2.2	5.5	7.5	9.2	9.2	11.0
Electric main motor	2.2	3.0	5.5	7.5	7.5	7.5
kW	2.2	3.0	5.5	7.5	7.5	7.5
Electric pump motor	0.37	0.37	0.55	0.55	0.55	0.75
kW	0.37	0.37	0.55	0.55	0.55	0.75
Power connection (standard)	3 x 380V, 50 c/s	3 x 380V, 50 c/s	3 x 380V, 50 c/s	3 x 380V, 50 c/s	3 x 380V, 50 c/s	3 x 380V, 50 c/s
Mix - inlet piping	10.0	10.0	16.0	16.0	16.0	25.0
øi mm	10.0	10.0	16.0	16.0	16.0	25.0
Ice cream outlet piping	25.0	25.0	38.0	38.0	38.0	38.0
ø mm	25.0	25.0	38.0	38.0	38.0	38.0
Air connection	3/8	3/8	3/8	3/8	3/8	3/8
ø inch	3/8	3/8	3/8	3/8	3/8	3/8
Air consumption	50	80	150	210	275	350
l/h	50	80	150	210	275	350
Required air pressure	7	7	7	7	7	7
bar	7	7	7	7	7	7
Water req. app. (max. +25°C)	350	600	1100	1550	1725	1800
l/h	350	600	1100	1550	1725	1800
Required water pressure	3 - 4	3 - 4	3 - 4	3 - 4	3 - 4	3 - 4
bar	3 - 4	3 - 4	3 - 4	3 - 4	3 - 4	3 - 4
Water inlet connection	1/2	1/2	3/4	3/4	3/4	3/4
ø inch	1/2	1/2	3/4	3/4	3/4	3/4
Water outlet connection	1/2	1/2	3/4	3/4	3/4	3/4
ø inch	1/2	1/2	3/4	3/4	3/4	3/4
Mutator speed, 50 c/s	400 - 1000	600	430	430	300	300
rpm	400 - 1000	600	430	430	300	300
OPTIONAL mutator speed		200 - 600	200 - 600	200 - 400	200 - 400	200 - 400
rpm		200 - 600	200 - 600	200 - 400	200 - 400	200 - 400
Standard mutator	Solid mutator	Solid mutator	Open type mutator	Open type mutator	Open type mutator	Open type mutator
	Solid mutator	Solid mutator	Open type mutator	Open type mutator	Open type mutator	Open type mutator
OPTIONAL equipment		Open type mutator	Solid mutator	Solid mutator	Solid mutator	
		Open type mutator	Solid mutator	Solid mutator	Solid mutator	
Mix pump	Piston type	Piston type	Piston type	Piston type	Piston type	Positiv
	Piston type	Piston type	Piston type	Piston type	Piston type	Positiv
Ice cream pump	Rotary piston type	Positiv	Positiv	Positiv	Positiv	Positiv
	Rotary piston type	Positiv	Positiv	Positiv	Positiv	Positiv

FAX TRANSMISSION**Technohoy**CARL HOYER A/S
Axel Kiers Vej 30
DK-8270 Aarhus-Højbjerg
D E N M A R K
TELEFAX +45 86 29 27 80

YOUR FAX NO:	009 33 88711830
NO. OF PAGES INCLUDING THIS ONE:	1
DATE:	08.10.92
TO COMPANY:	Doyeuropa
ATT.:	Mr. E. Hoenen
FROM:	Mrs. Gitte Simonsen
PLEASE CALL US AT +45 86 29 21 88 IF TRANSMISSION IS RECEIVED INCOMPLETE	

Dear Sir.

Referring to our telephone conversation yesterday, I am very pleased to confirm your order:

ORDER CONFIRMATION NR.: 33-C1476
SPARE PARTS FOR MF 50 NR. 67

Drawing U5437:
1 Bearing (pos. 21)

DKK 480,-

Time of delivery:

I send it today by mail. I hope that we do not get the same trouble as last time we used the Post Office.

Price:

Ex Works Aarhus, DK.

Terms of payment:

30 days net.

we thank you for the order, and in case you have any questions, please do not hesitate to contact us.

Best regards,

TECHNOHOY CARL HOYER A/S

Gitte Simonsen

Gitte Simonsen

1/1

**FØLGESEDEL
DELIVERY NOTE**

Technohoy
CARL HOYER A/S

Axel Kiers Vej 30
DK-8270 Aarhus - Højbjerg

Phone national 86 29 21 88
Phone internat. +45 86 29 21 88
Telefax +45 86 29 27 80
Carl Hoyer private +45 86 27 04 45
A/S reg. nr. 65240
Bankers: Den Danske Bank
S.W.I.F.T. Address:
DABA DK KK 4620135909
Postal Account 8 17 12 38

DOVEUROPE S. A.
Route de Saverne
F-67790 Steinbourg

Your ref.: **Mr. Eric Hoenen**

Our ref.: **Mrs. G. Simonsen**
C1476

Date: **08.10.92**

Spare parts for MF 50

1 pcs. Bearing D 1267, Draw. U5437 Pos 21

Doveurope
Route de Saverne
F - 67790 Steinbourg

Axel Kiers Vej 28-30
DK-8270 Aarhus - Højbjerg

Phone national 86 29 21 88
Phone internat. +45 86 29 21 88
Telefax +45 86 29 27 80
Carl Hoyer private +45 86 27 04 45

A/S reg. nr. 201200
Bankers: Den Danske Bank
S.W.I.F.T. Address:
DABA DK KK 4620135909
Postal Account: 8 17 12 38

Your ref.:

Our ref.: GS

Date: 07.10.92

Dear Mr. Hoenen

As promised in our telephone conversation today I hereby send you the drawing of the outlet pump at your MF 50.

Order confirmation for the star-bearing follows.

Best regards,

TECHNOHOY CARL HOYER A/S

Gitte Simonsen

Gitte Simonsen

Spareparts manager

TECHNOHOY

MIX PUMPE
MIX MPUMP
MIX PUMPE
POMPE DE MIX

FPJ

MF 50

Fig No.	Pos No	Qty	Part No.	Description			
3	1*	2		Pakning	Gasket	Packung	Joint
3	2	1		Dæksel	Cover	Deckel	Couvercle
3	3*	1		O-ring	O-ring	O-Ring	Anneau en O
3	4	1		Stjernehjul	Star wheel	Sternrad	Etoile à arrêtoire
3	5	1		Lejebøsning	Bush	Lagerbuchse	Bague
3	6	1		Aksel	Shaft	Welle	Essieu
3	7*	1		O-ring	O-ring	O-Ring	Anneau en O
3	8	1		Løbehjul	Impeller	Laufgrad	Impulseur
3	9	1		Lejebøsning	Bush	Lagerbuchse	Bague
3	10	1		Hus	Housing	Gehäuse	Carter de pompe
3	11	3		Skrue	Screw	Schraube	Vis
3	12	1		Skrue	Screw	Schraube	Vis
3	14	1		Spillerumsføler	Clearance-feeler	Spielraumfühler	Toucheer de Jeu
3	*	-		Pakningsæt	Gasket set	Packungssatz	Jeu de garnitures

Carter de la pompe

Snit A-A

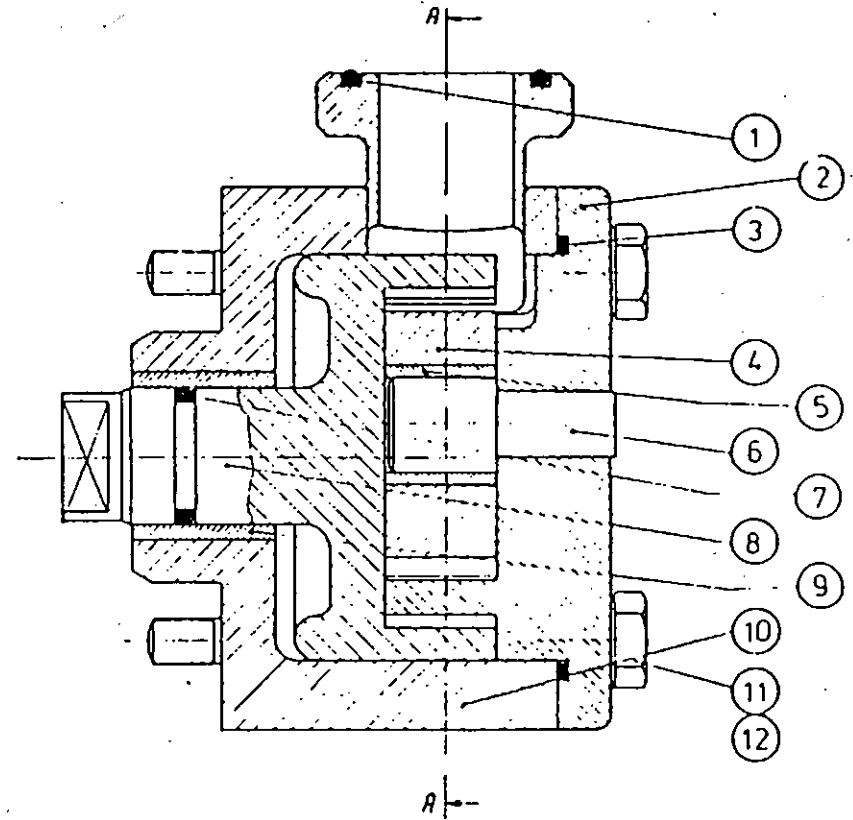
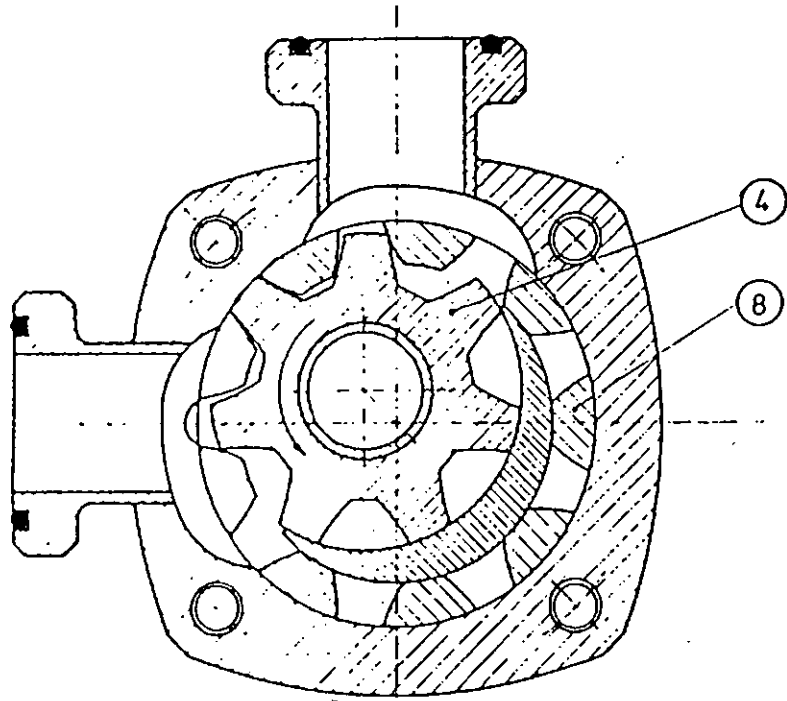

Technohoy
CARL HOYER A/S

Axel Kiers Vej 30
DK-8270 Aarhus - Højbjerg

FAX TRANSMISSION**Technohoy**

YOUR FAX NO:	00933 88 71 18 30
NO. OF PAGES INCLUDING THIS ONE:	1
DATE:	22.05.92
TO COMPANY:	Doveurope
ATT.:	Mr. Eric Hoenen
FROM:	Mrs. Gitte Simonsen
PLEASE CALL US AT +4586292188 IF TRANSMISSION IS RECEIVED INCOMPLETE	

CARL HOYER A/S
Axel Kiørs Vej 30
DK-8270 Aarhus-Højbjerg
D E N M A R K
TELEFAX +45 86 29 27 80

Dear Mr. Hoenen

Referring to our telephone conversation yesterday I can tell you that the parcel with the spare parts for your MF50 freezer already has arrived to France. Therefore I am sure that you will receive it shortly. - BUT if you have not received it on Tuesday, (the 26. may), please let me know. Then the post office must make a search for the parcel.

Best regards,

TECHNOHOY CARL HOYER A/S

Gitte Simonsen

Gitte Simonsen

Ces pièces sont à relancer!

11.05.92

Départ permis pour fin semaine ^{il leur} (manque une des pièces)

↳ arrivée fin semaine prochaine
ou alors il faut qu'on leur demande
un transport urgent...

CDE N° 81604

SAISIE LE: 07.04.92 PAR: JFB

DE PRIX (2) COMMANDE (2) APPROVISIONNEMENT

FOURNISSEUR (5)	ARTICLE: DESIGNATION ET SPECIFICATIONS	Type	REFERENCE ARTICLE CODE MARS	QUANTITE (3)	UNITE	PRIX UNITAIRE H.T. DEVISE =	LIVRAISON DATE (6)	IMPUTATION ANALYT. TYPE (7) N° DEST. (Budget) (1)
NOHOY 1404ER A/S.	SIV 10 DOK			1		535 DKK	17.04.92	62 02 03 02 VISA (4):
				1		585 DKK		VISA (4):
	2000 15 100000			3		22 DKK		VISA (4):
	100000			1		32 DKK		VISA (4):
	100000			1		9 DKK		VISA (4):
	U-200005			1		885 DKK		VISA (4):
	FASSITE VATIVE CASING			2		254 DKK		VISA (4):
	JOINTS FOR ALL THE TIRE 200L			1		2871 DKK		2871 3769 VISA (4):
	TOTAL			0				

EXPEDITION: PAIEMENT: DEMANDEUR: M. GRENZ AUC RESPONS. BUDGET (4): ACHETEUR: [Signature] 07.04.92

INS GRES MANDE A CONFIRMER: OUI NON

FAX TRANSMISSION

Technohoy

CARL HOYER A/S
 Axel Kiars Vej 30
 DK-8270 Aarhus-Holbjerg
 DENMARK
 TELEFAX +45 86 29 27 80

YOUR FAX NO:	009 33 88711830
NO. OF PAGES INCLUDING THIS ONE:	2
DATE:	06.04.92
TO COMPANY:	Doveurope
ATT:	Mr. E. Hoener
FROM:	Mrs. Gitte Simonsen
PLEASE CALL US AT +45 86 29 21 88 IF TRANSMISSION IS RECEIVED INCOMPLETE	

Dear Sir,

Referring to our telephone conversation and telefax, I am very pleased to confirm your order:

ORDER CONFIRMATION NR.: C-1323E
SPARE PARTS FOR MF 50 NR. 67

Drawing		Price each:	Total:
Drawing U5437:			
1 Stuffing-box (pos. 9)	<i>spring + padding resort +</i>	DKK 535,-	DKK 535,-
1 Pair of knives (pos. 22)		DKK 585,-	DKK 585,-
Drawing D9406:			
3 Roller (pos. 15)	<i>pieces at the ppe a nice</i>	DKK 24,-	DKK 72,-
1 Ball (pos. 8)		DKK 32,-	DKK 32,-
1 O-ring (pos. 6)		DKK 8,-	DKK 8,-
1 Pressure valve casing (pos. 7)		DKK 565,-	DKK 565,-
2 Set of joints for all the freezer		DKK 277,-	DKK 754,-

Total price.....DKK 2871,-

x 0,88

I suppose the joints you are ordering are the total number of packages (O-rings f.ex).

Technohoy
CARL HOYER A/S

DOVEUROPE

06.04.92

Time of delivery: About one week.

Price: EX Works Aarhus, DK.

Terms of payment: 10 days net.

We thank you for the order, and in case you have any questions,
please do not hesitate to contact us.

Best regards,

TECHNOHOY CARL HOYER A/S

Gitte Simonsen

Gitte Simonsen

GENERAL INFORMATION

- I-01 Spare parts
- I-02 General information
- I-02 Working principle
- I-03 Optional Equipment
- I-04 Technohoy product description

INSTALLATION

- II-01 Drawing MF 50
- II-03 Electric connection
- II-03 Air connection
- II-04 Water connections
- II-04 Connection for mix
- II-04 Connection for ice cream
- II-04 The built-in refrigerating system
- II-05 Preparations before the first start
- II-06 Adjusting of digital thermometer

OPERATION

- III-01 Starting the freezer
- III-03 Stopping the freezer
- III-04 Day to day running of the freezer
- III-06 Trouble shooting
- III-07 Trouble shooting
- III-08 Cleaning programme

DESCRIPTION AND MAINTENANCE

- IV-01 The ice cream and air system
- IV-03 Non-return valve
- IV-03 Maintenance
- IV-04 The mix pump and driving arrangement
- IV-05 The ice cream pump
- IV-05 Adjusting the pump ratio
- IV-07 The refrigerating system and refr. components
- IV-10 The freezing cylinder assembly and main drive
- IV-11 Maintenance
- IV-13 Speed adjusting of the pumps
- IV-14 Reconditioning of worn scraper blades
- IV-15 The electrical installation

TECHNOHOY

GENERAL INFORMATION

MF 50

I-01

2

A

SPARE PARTS

When ordering spare parts for your Technohoy Continuous Ice Cream Freezer, please always state Machine Type, Machine Serial Number, Drawing Number and Figure Number.

EXAMPLE:

MF 50 Number 42, Drawing C 3100. Position Number 7.

T E C H N O H O Y

Carl Hoyer A/S

30 Axel Kiersvej,

DK-8270 ARHUS-HOJBJERG

DENMARK

PHONE +45 86 29 21 88

TELEFAX +45 86 29 27 80

TECHNOHOY

GENERAL INFORMATION

MF 50

I-02

3

A

GENERAL INFORMATION

The TECHNOHOY Ice Cream Freezers MF 50, MF 75, MF 100, MF 100L, MF 200 and MF 300 are self-contained, units with built-in refrigerating systems. The MF 300 Twin-Freezer functions as two self-contained MF 300 single freezers in one frame.

WORKING PRINCIPLE

The ice cream mix is metered into the freezing cylinder by a positive pump, and a constant flow of air is fed in together with the mix. During the passage through the cylinder the air is whipped into the mix by the action of a rotating mutator. Liquid Freon 502, evaporating in the cooling jacket, surrounding the freezing cylinder, supplies the refrigeration. Hardened scraper blades of the best quality, hinged to the mutator, scrapes off the ice cream, continuously as it freezes on to the inside cylinder wall. Whipping and freezing takes place under air pressure, which can be regulated to obtain the desired overrun. A second pump forwards the finished product from the outlet of the cylinder to the discharge piping. The flow of liquid Freon is regulated by an automatic thermovalve, and the evaporating pressure and temperature is regulated by an automatic back pressure regulator.

The smallest model, MF 50, which is designed primarily for laboratory purposes, has a variable speed drive for the mutator, allowing any speed between app. 400 and 1000 r.p.m.

TECHNOHOY

GENERAL INFORMATION

MF 50

I-03

4

A

OPTIONAL EQUIPMENT

The mutator in the MF 50 is of a special flat and solid design. The freezer has a flowmeter with flowcontroller, which makes it possible to check the constancy of the airflow.

AS AN OPTIONAL, all MF Freezers can be delivered with a frequency converter for regulation of the mutator speed.

DRAWING C 16440

1. Start and stop of pump motor
2. " " " " main driving motor
3. " " " " CIP or air compressor
(IF ANY)
4. " " " " refr. compressor
5. Air connection to cylinder
6. Compound pressure and temperature gauge
for Freon
7. Back pressure regulating valve
8. Tee in mix line with non-return valve
9. Pump speed regulator
10. Mix line
11. Mix inlet pump
12. Suction pressure gauge
13. Pressure control
14. Condensing pressure gauge
15. Mix connection
16. Ice cream outlet pipe
17. Ice cream outlet pump
18. Vertical ice cream pipe
19. Front cover of freezing cylinder
20. Speed regulation of mutator
21. Air pressure regulating valve (IF ANY)
22. Air pressure gauge
23. Amperemeter for main driving motor
24. Rear end cylinder cover with rotary shaft
seal
25. Water regulating valve
26. Screwed connection for electrical cable
27. Air inlet
28. Water outlet
29. Water inlet
30. Main current cabinet
31. Digital thermometer
32. Sensor for digital thermometer
33. Flowmeter/Control and read out equipment
34. Tachometer

TECHNOHOY

INSTALLATION

MF 50

II-02

6

TN

35. Main switch / Circuit interrupter
36. Pressure gauge for measuring the cylinder pressure
37. Encoder
38. VLT - Frequency converter for regulation of mutator

14

13

12

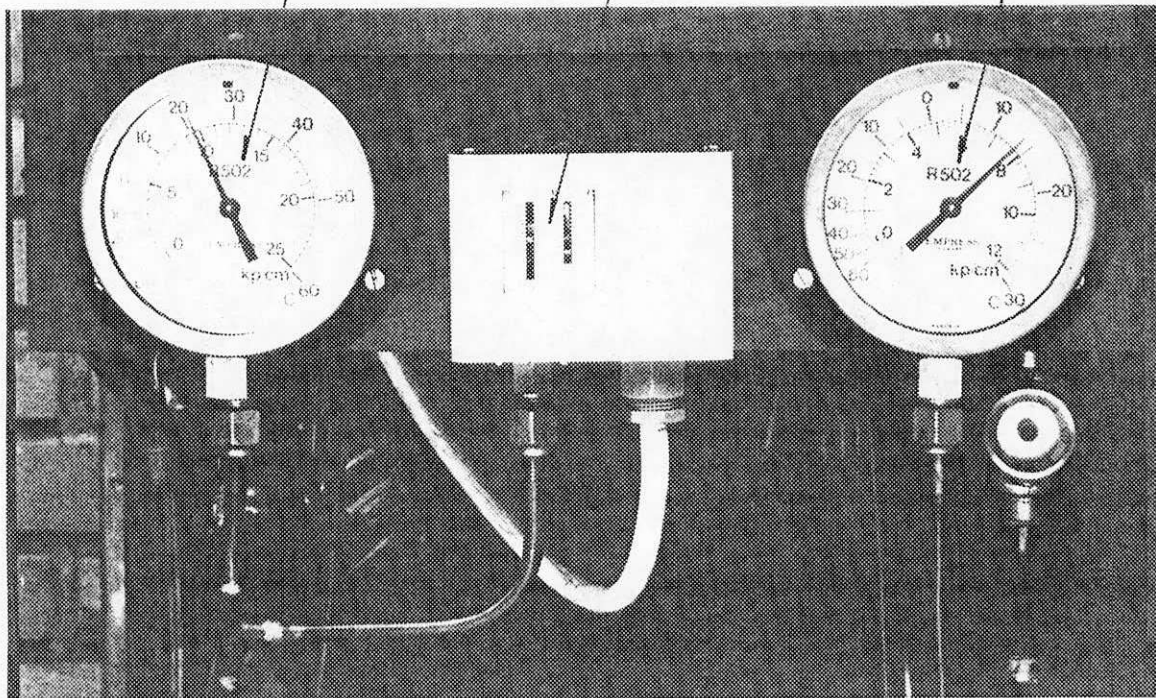

mm

Alle mål uden tolerance

Målestok:

Materiale:

Technohoy
 CIVILINGENIØR OG HØYER
 AARHUS - DANMARK

Konstr. 09.12.1982.

Tegn. *C. Hoyer*

Godk.

Tegning nr.:

Temperature gauges F-502

D 5431

TECHNOHOY

INSTALLATION

MF 50

II-03

7

TN, -200

INSTALLATION

The freezer is completely self-contained and needs only connections for electricity, cooling water, compressed air and ice cream mix, to be ready for operation. To take full advantage of this system, the freezer is equipped with transport wheels and can easily be moved from one location to another in the factory.

ELECTRIC CONNECTION

The freezer - standard model is built with a three phase ac system for 380V, 50 c/s with earth connection, BUT NO O-CONDUCTOR. For safety reasons all control circuits are fed from a transformer to 24 volts.

AS AN OPTIONAL, all MF Freezers can be delivered with the required voltage and frequency.

A main current cabinet contains fuses and starters with overload protection. A flexible cable, with four cores of ample size to comply with local regulations, should be drawn through the screwed connection 26 on drawing C 16440, and from there to another screwed connection in the bottom of the cabinet. The three phases in the cable should be connected to the main switch / circuit interrupter L1, L2, L3 and ground terminals.

AIR CONNECTION

A supply of clean, dry air under a pressure of 7 bar should be provided. Normally the air is taken from an existing supply system but, as an alternative, the freezer can be supplied with an oil-free, built-in air compressor of the diaphragm type.

An air filter and a water filter can be supplied as optional extra.

TECHNOHOY

INSTALLATION

MF 50

II-04

8

50,1TP

WATER CONNECTIONS

The inlet and outlet for cooling water have adaptors for rubber water hoses. A water pressure of 3-4 bar is required.

CONNECTION FOR MIX

This connection must be made with utmost care to obtain trouble free operation. It is essential, that the mix is fed to the inlet of the mix pump under positive pressure. This can be obtained by placing the mix tank at a higher level than the inlet of the mix pump, so that the mix can flow to the pump by gravity alone. Should this not be possible, it is recommended to install a centrifugal booster pump, which then can be used for CIP-cleaning also. The important thing is to avoid sub-atmospheric pressure in the mix line AND THEREBY TO PREVENT THE INTAKE OF AIR THROUGH POSSIBLE LEAKS, which would make accurate control of the over-run impossible.

CONNECTION FOR ICE CREAM

It is important to keep the outlet piping as short as possible and to avoid to make reductions in diameter relative to the size of the outlet of the discharge pump. Never use insulated ice cream pipes.

Concerning the working conditions for the outlet pump, please see the enclosed pump manual.

THE BUILT-IN REFRIGERATING SYSTEM

Is charged with the proper amount of refrigerant, Freon, and compressor oil. Normally no adjustment are required before initial starting up. The Freon pressure gauges 12 and 14 should, by standstill, show a temperature close to the temperature of the surroundings.

TECHNOHOY

INSTALLATION

MF 50

II-05
TN, 50,

9

VLT, HM

PREPARATIONS BEFORE THE FIRST START

If however the gauges show zero pressure, it is an indication, that the freezer has been damaged during transport with loss of the Freon charge as consequence.

If that is the case, a competent refrigerating engineer should be called to find and repair the leak, and recharge the system with Freon. Freon type indication is stated in "Refrigeration components IV-07".

NO OTHER REFRIGERANT MUST EVER BE USED.

BEFORE ATTEMPTING TO START ANY OF THE ELECTRIC MOTORS THE FIRST TIME, THE MUTATOR SHOULD BE REMOVED FROM THE FREEZING TUBE. To do this, remove the connecting pipe, 18 on C 16440. Then turn the cylinder head 1/12 of a revolution anti-clock-wise, by hand. NEVER USE THE CONNECTING PIPE AS A HANDLE ! It could very easily be damaged, with leaking o-ring joints as consequence. The head of the freezing cylinder can now easily be removed and the mutator be pulled out.

Now start the pump motor. The direction of rotation according to the arrow on the pumpgear, should be checked. THE ROTATION SHOULD BE CLOCKWISE.

The direction of rotation can be changed by interchanging the cable connections at the terminals L1 and L2.

Please see enclosed Wiring Diagram

TECHNOHOY

INSTALLATION

MF 50

II-06

10

TN,DF

The main motor rotation can only be changed in the motor connecting box or in the output terminal in the VLT. The rotation of the main shaft must be ANTICLOCKWISE, when seen through the freezing cylinder.

Remove the piston from the mix pump by removing the pin and pushing back the yoke. Reinsert the pin in the next hole in the yoke. Remove the mix pipe between mix pump and tee, 10 on drawing C 16440. Unscrew the other two connections of the tee. The rear end cylinder cover with rotary shaft seal can now be removed.

Leave the non-return valve connected to the air hose and make a preliminary test of the air system by turning the knob CHANNEL-1 on the flowmeter clockwise, until the air pressure gauge responds. At about 0.5 - 1 bar, the non-return valve should start to blow. Clean all the parts and reinstall them.

An edible lubricating grease should be used for the shaft seal, the bearings and wherever parts move one against the other.

The spring should be able to move the seal ring on the shaft, after having been compressed. Also use this lubricant to keep the O-rings in place in their grooves. It facilitates assembly and avoids damage to the O-rings.

ADJUSTING OF DIGITAL THERMOMETER

The digital thermometer is adjusted (by an adjusting screw, please see enclosed wiring diagram) by comparing it to a reference thermometer of a known liability. This is done in an ice water solution at 0°C. The display must at this temperature show 0.0°C.

TECHNOHOY

OPERATION

MF 50

III-01

11

VLT, HM

STARTING THE FREEZER

1. The VLT regulator should be placed more than 60% before starting the main motor in order to have sufficient torque.
2. Make sure that there is an adequate amount of mix in the mix supply tank.
3. Start the pumps and set the pump speed regulator at a low capacity.
4. Wait until mix comes out of the discharge pipe. Then start the main motor.
5. Start the refrigerating compressor and set the evaporating temperature at about -15o to -20o C. Wait for about 2 minutes to cool down the cylinder.
6. Raise the air pressure slowly from 0 to about 4 bar.

The freezer is now in operation. Wait until the product comes out in a constant flow before making further adjustments.

First considerations are overrun and stiffness.

Check the overrun by weighing a known volume, for instance 1.0 l. For ice cream of normal composition the liter weight should be around 550 g. The overrun is increased by increasing the air pressure, and vice versa. Stiffness is depending on the Freon evaporating temperature and the throughput of ice cream. The lower the evaporating temperature and the lower the throughput, the stiffer the product will be.

TECHNOHOY

OPERATION

MF 50

III-02

12

TN

When stiffness is increased, the load on the main motor is also increased, which is reflected by a higher reading of the motor amperemeter.

When increasing stiffness, the motor amperemeter should therefore always be under careful observation to avoid overloading the motor, which eventually might result in so called freeze-up. See later.

Now increase pump speed to obtain higher output, if so desired. This will have a negative effect on stiffness, which must be compensated for by lowering the evaporating temperature. By repeating these alternating adjustments, the desired output and overrun can be reached within the capacity of the freezer. Overrun will vary simultaneously with variations in output and stiffness. Check the overrun and adjust the air pressure accordingly. Output cannot be increased beyond a certain point determined by mix recipe, and the capacity of the refrigerating compressor. This point has been reached, when the evaporating temperature cannot be driven further down. The back pressure regulating valve in the refrigerating system is then wide open. The Freon pressure gauges 6 and 12 on drawing C 16440 will then show nearly the same evaporating temperature.

Adjustments should always be made one at a time, and sufficient time should be allowed for observation of the effect, before the next adjustment is made.

When ice cream outlet temperature goes lower than -60 C to -70 C, be careful not to have a "freeze-up".

TECHNOHOY

OPERATION

MF 50

III-03

13

DF

STOPPING THE FREEZER

To stop the freezer proceed as follows:

1. Stop the refrigerating compressor.
2. Turn the knob CHANNEL-1 on the flowmeter slowly until the air pressure gauge reads zero.
3. Wait until the product becomes liquid and the amperemeter shows no-load current.
4. Stop the main driving motor.
5. Stop the pumps.

IT IS IMPORTANT, THAT THIS SEQUENCE IS FOLLOWED CLOSELY

TECHNOHOY

OPERATION

MF 50

III-04

14

50STMP

DAY TO DAY RUNNING OF THE FREEZER

The freezer should produce ice cream with uniform stiffness and overrun. It should be possible to obtain the desired values by using the controls on the freezer correctly. It is essential for close overrun control, that the pressure in the inlet of the mix pump is constant and positive. In this way intake of false air is avoided, through possible leaks in the mix line. See page II-05

The experienced operator always keeps a keen eye on his instruments, because they reflect the inner life of the freezer. The air pressure gauge response to adjustments of the air pressure must be immediate. If also the non-return valve is in good condition, one can be reasonably sure, that the air system is in order.

The amperemeter shows the load condition of the main driving motor. The motor load depends on, how hard freezing is, i.e. how low the Freon evaporating temperature is, and how high the throughput is. When adjusting the Freon temperature, or the throughput, downwards, follow the increase of the ampere reading. THERE IS ALWAYS A POTENTIAL RISK OF OVERLOADING THE MOTOR. Eventually the V-belts may slip or the thermal overload protection may stop the motor. In either case a "freeze-up" is a reality.

The amperemeter has one more important function. Besides the slow, smooth movement of the needle, caused by changes in the evaporating temperature, fluctuations of the mix temperature, varying throughput etc. the needle can also show quick and abrupt movements.

TECHNOHOY

OPERATION

MF 50

III-05

15

STMP

They are an indication, that the scraper blades do not function properly. They do not scrape to the bottom all the time, but slide over a thin film of ice cream, frozen to the cylinder wall, especially if the evaporating temperature is very low, until they suddenly cut through to the cylinder wall again, which causes a jump in the motor current. If these jumps get very pronounced, the scraper blades should be inspected and reconditioned. See later.

The third instrument is the compound gauge showing both the evaporating pressure and the evaporating temperature. For the operation of the freezer, only the evaporating temperature is of interest. It is not possible to say, what the evaporating temperature should be. The lower throughput, the stiffer the ice cream, the lower freezing point of the mix the lower the evaporating temperature has to be.

On the following two pages some typical questions and answers are tabulated.

<u>OPERATION</u>			MF 50	III-06
<u>TROUBLE SHOOTING</u>			16	50
Product too soft	Evaporating temperature too high	Back pressure reg. valve not opened enough	Open valve to lower evaporating temperature	
		Compressor loaded to full capacity	Reduce pump capacity	
		Setting of thermoexpansion valve incorrect	Readjust valve <u>See valve instructions,</u> included	
		Compressor capacity diminished	<u>See maintenance instruction for compressor,</u> included	
	Scraper blades worn		Recondition blades. <u>See IV-14</u>	
	Mix temperature too high		Reduce mix temperature	
	Freon charge insufficient		Replenish Freon charge Freon type indication is stated in refrigeration components IV-07. <u>Freon charge: See label attached to the condenser</u>	
	Freezing point of mix too low			

OPERATION TROUBLE SHOOTING		MF 50	III-07
		17	TP DF
Overrun too low	Air pressure too low		Adjust flowmeter
	Pump ratio not correct		Adjust pump ratio IV-05 or contact Technohoy
	Finished product too cold or too warm		Try with different product outlet temperatures
	Lack of correct overrun additives		
Overrun too high	Air pressure too high		Adjust flowmeter
	Air leaks in the mix line		<u>See II-04</u>
	Too much rework in the mix tank		Use only freshly prepared mix
Overrun unsteady	Air leaks in the mix line		
	Too much rework in the mix tank		Use only freshly prepared mix
Air slugs in the finished product	Too much rework in the mix tank		Use only freshly prepared mix
	Poor air holding ability of the mix		
	Entering mix too cold		
	Pump ratio not correct		Adjust pump ratio IV-05 or contact Technohoy

CLEANING PROGRAMME

MF 50

III-08

EXAMPLE

18

A

Stage	Approx. time min.	Approx. temp. oC
1. Pre-rinse with water. Outgoing water to drain.	7	10 - 15
2. Lye wash - 1% caustic soda solution with wetting agent and phosphate additives. Is returned to tank after use.	12	65 - 70
3. Hot water sterilisation. Water dis- places lye and goes to drain after regenerative cooling.	12	90 - 95
4. Water goes to drain and graduate cooling.	--	---

The times mentioned above are normative and the programme is effective from a bacteriological point of view, but it does not prevent hard rinsing water from depositing lime salts.

These can be removed once or twice every season by means of acetic acid or citric acid (PH 3.5 - 4.5) according to the following procedure:

The freezer and the pumps are disassembled and the individual parts are washed in the above mentioned weak acid (max. 100 ppm), and are then immediately after carefully rinsed in clean, cold water and dried.

WARNING! Do not use acidiferous or chlorine-containing detergent apart from the exception referred to.

Chlorine pits and makes mutator and scraperblades rust and pits chrome.

Acid attacks chrome!

OVERRUN TABLE - Met. c

Weight in grams of Finished Product in various sized containers (x)			Overrun percent shown for various weights of Mix or Product Input (indicated in grams per liter) (x)			
1/4 Liter	1/2 Liter	1 Liter	1080 grams % overrun	1092 grams % overrun	1104 grams % overrun	1116 grams % overrun
120 gr	240 gr	480 gr	125 %	127 %	130 %	133 %
122 gr	243 gr	485 gr	122 %	125 %	127 %	130 %
123 gr	246 gr	492 gr	120 %	122 %	124 %	127 %
124 gr	249 gr	498 gr	117 %	119 %	121 %	124 %
126 gr	252 gr	504 gr	114 %	117 %	119 %	121 %
128 gr	255 gr	510 gr	112 %	114 %	116 %	119 %
129 gr	258 gr	516 gr	110 %	112 %	114 %	116 %
130 gr	261 gr	522 gr	107 %	109 %	111 %	114 %
132 gr	264 gr	528 gr	105 %	106 %	109 %	111 %
134 gr	267 gr	534 gr	102 %	104 %	106 %	109 %
135 gr	270 gr	540 gr	100 %	102 %	104 %	107 %
136 gr	273 gr	546 gr	97 %	100 %	102 %	104 %
138 gr	276 gr	552 gr	96 %	98 %	100 %	102 %
139 gr	279 gr	558 gr	94 %	96 %	97 %	100 %
141 gr	282 gr	564 gr	91 %	94 %	95 %	98 %
143 gr	285 gr	570 gr	89 %	92 %	93 %	96 %
144 gr	288 gr	576 gr	88 %	90 %	91 %	94 %
146 gr	291 gr	582 gr	86 %	88 %	89 %	92 %
147 gr	294 gr	588 gr	84 %	86 %	87 %	90 %
148 gr	297 gr	594 gr	82 %	84 %	85 %	88 %
150 gr	300 gr	600 gr	80 %	82 %	84 %	86 %
151 gr	302 gr	604 gr	78 %	80 %	82 %	84 %
153 gr	306 gr	612 gr	76 %	78 %	80 %	82 %
154 gr	309 gr	618 gr	75 %	77 %	78 %	80 %
156 gr	312 gr	624 gr	73 %	75 %	76 %	79 %
157 gr	315 gr	630 gr	71 %	73 %	75 %	77 %
159 gr	318 gr	636 gr	70 %	72 %	73 %	75 %
160 gr	321 gr	642 gr	68 %	70 %	71 %	74 %
162 gr	324 gr	648 gr	67 %	68 %	70 %	72 %
164 gr	328 gr	654 gr	65 %	67 %	68 %	70 %
165 gr	330 gr	660 gr	64 %	65 %	67 %	69 %
166 gr	333 gr	666 gr	62 %	63 %	66 %	67 %

(x) Before calculating weights, make certain that weight of container is subtracted.

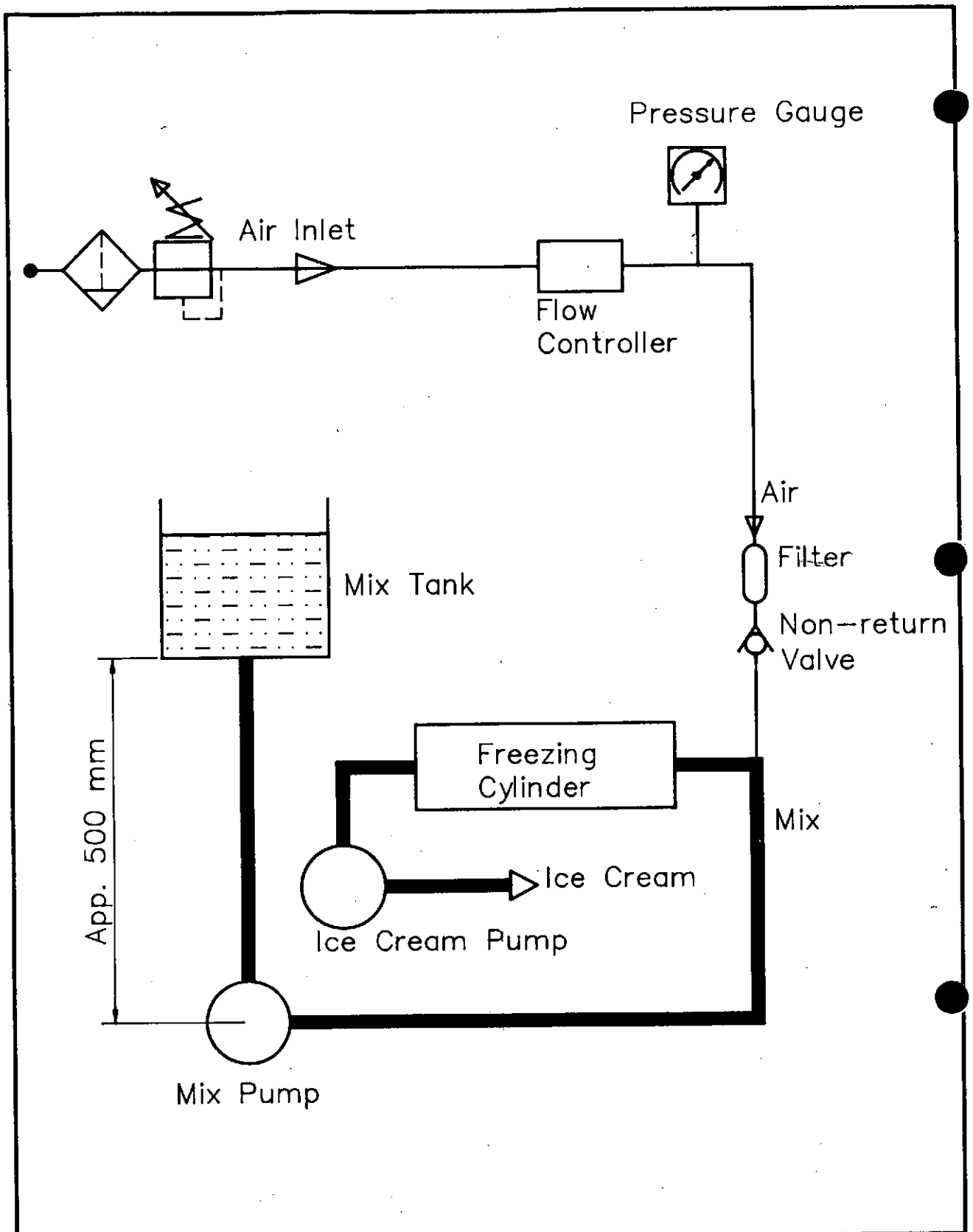

Tolerancer ifølge DS 2075, hvor intet andet er angivet.		Antal	Stykketegn.	Mærke	Evt. bem.	
Afkortningsmål:		TECHNOHOY CARL HOYER A/S AARHUS - DENMARK			Skala	Tegn. sc
Antal	Dimension				1:1	Dato
		Ice Cream/Air System				
					D16442	

TECHNOHOY

DESCRIPTION AND MAINTENANCE

MF 50

IV-01

19

TN, DF

THE ICE CREAM- AND AIR SYSTEM

The TECHNOHOY freezers are continuous freezers, which means that they, unlike batch freezers, have two pumps to supply a continuous and constant flow of ice cream mix to the freezer and to meter the finished product out of the freezer. The air, necessary to obtain the desired overrun, is fed to the inlet end of the freezing cylinder, together with the ice cream mix.

D 16442 shows a schematic diagram of the ice cream- and airtsystem. Mix from the supply tank is taken by the mix pump and is pumped to the inlet end of the freezing cylinder.

A build in flowmeter measures the flow of air mixed into the ice cream. An air pressure gauge shows the actual air pressure. The air passes a disposable filter and a non-return valve, and is mixed into the ice cream mix.

In the freezing cylinder air and mix are whipped thoroughly together by the action of the mutator, to form an emulsion with finely divided air bubbles. Simultaneously the mix is cooled down and partly frozen by the contact with the refrigerated cylinder wall. The mutator, which rotates in the cylinder, at a comparatively high speed, serves two purposes. First it performs the just mentioned whipping. Secondly it constantly scrapes off the ice cream, which freezes on to the cylinder wall. For this purpose the mutator is equipped with a set of two scraper blades, hinged in such a way that they can swing out and contact the cylinder wall under the influence of centrifugal force.

TECHNOHOY

DESCRIPTION AND MAINTENANCE

MF 50

IV-02

20

50,75

The freezing tube is hard chromium plated on the interior surface, to minimize wear of the scrapers.

The finished product passes to the ice cream pump and to the outlet.

Control of overrun is accomplished as an interplay between the capacities of these two pumps and the air pressure, as set by the flowmeter. It is obvious, that the ice cream pump must have a higher capacity than the mix pump. The difference in capacity is made up for by the air, the volume of which is reduced because of the prevailing pressure.

After passage of the second pump the air in the product re-expands to normal volume and gives the product the desired overrun, provided that the air pressure and the difference in pump capacities, pump ratio, were right. . These are the two factors by which the overrun can be controlled.

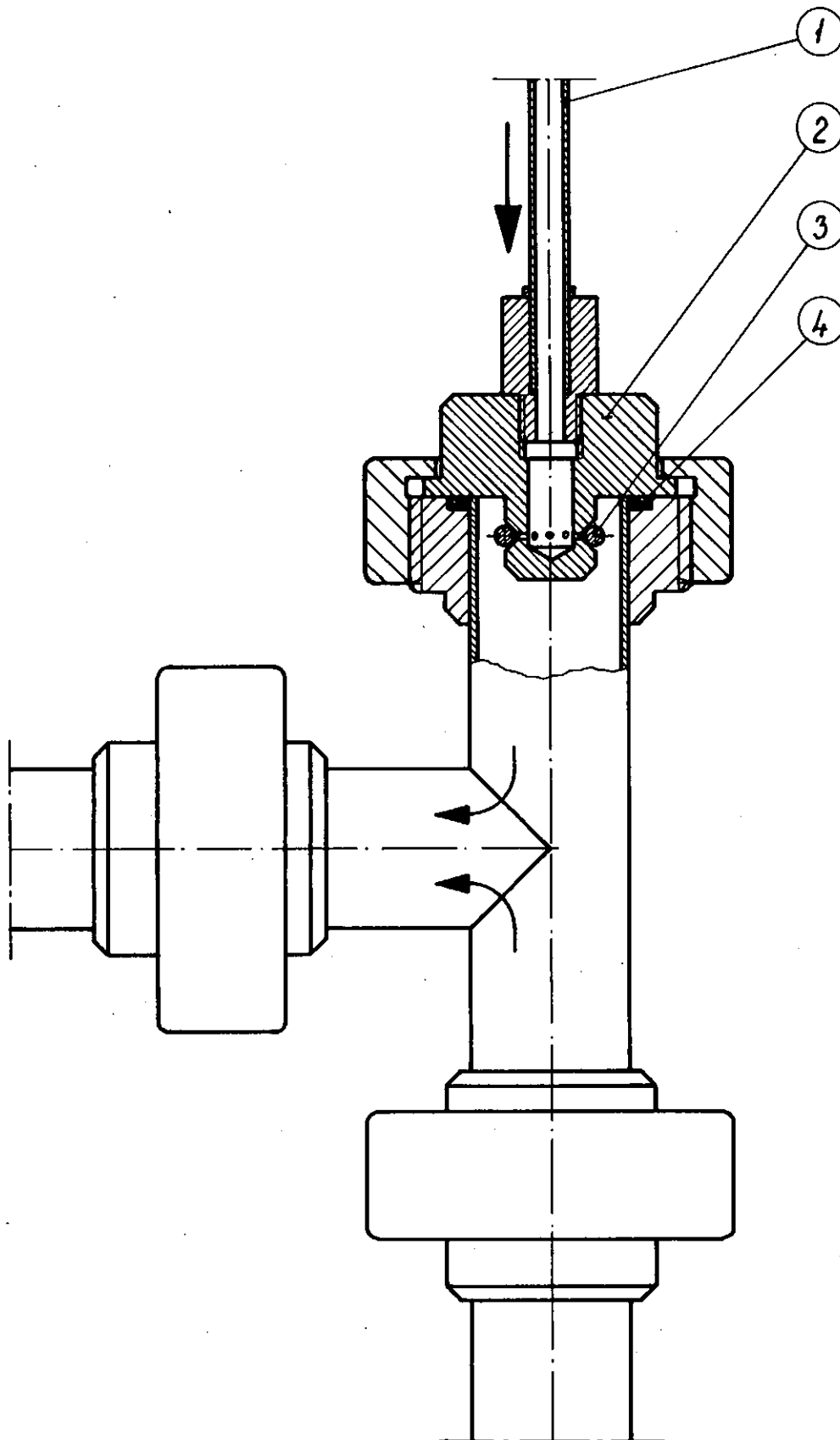

mm

Alle mål uden tolerance ±

	Materiale	Model nr.	Lager nr.	Målforhold	Tegn.	78.06.15.
				1:1	Kont.	R
Genstand:				Tg. nr.		
T-stykke m/kontraventil.				D 3141		

TECHNOHOY

DESCRIPTION AND MAINTENANCE

MF 50

IV-03

21

-300

NON-RETURN VALVE

D 3141 shows a section through the non-return valve, which is placed in the top of the sanitary tee in the mix pipe from the mix pump.

Air under constant pressure enters the valve body 2 through the tube 1, the other end of which is connected to the air control system. The valve body 2 carries an O-ring 3 in a V-groove, the bottom of which is connected to the inlet port of the valve body through a number of radial holes. The valve body is sealed against the tee by means of an O-ring 4.

It takes about 1.2 to 1.5 bar air pressure to lift the O-ring 3 from the seat and thereby to open the valve. THE ACTUAL PRESSURE IN THE FREEZING CYLINDER IS THEREFORE 1,2 TO 1,5 BAR LOWER THAN THE VALUE SHOWN BY THE AIR PRESSURE GAUGE.

MAINTENANCE

IT IS VERY IMPORTANT, that the two O-rings 3 and 4 are in perfect condition to avoid counter flow through the valve. For the same reason the valve should be kept clean.

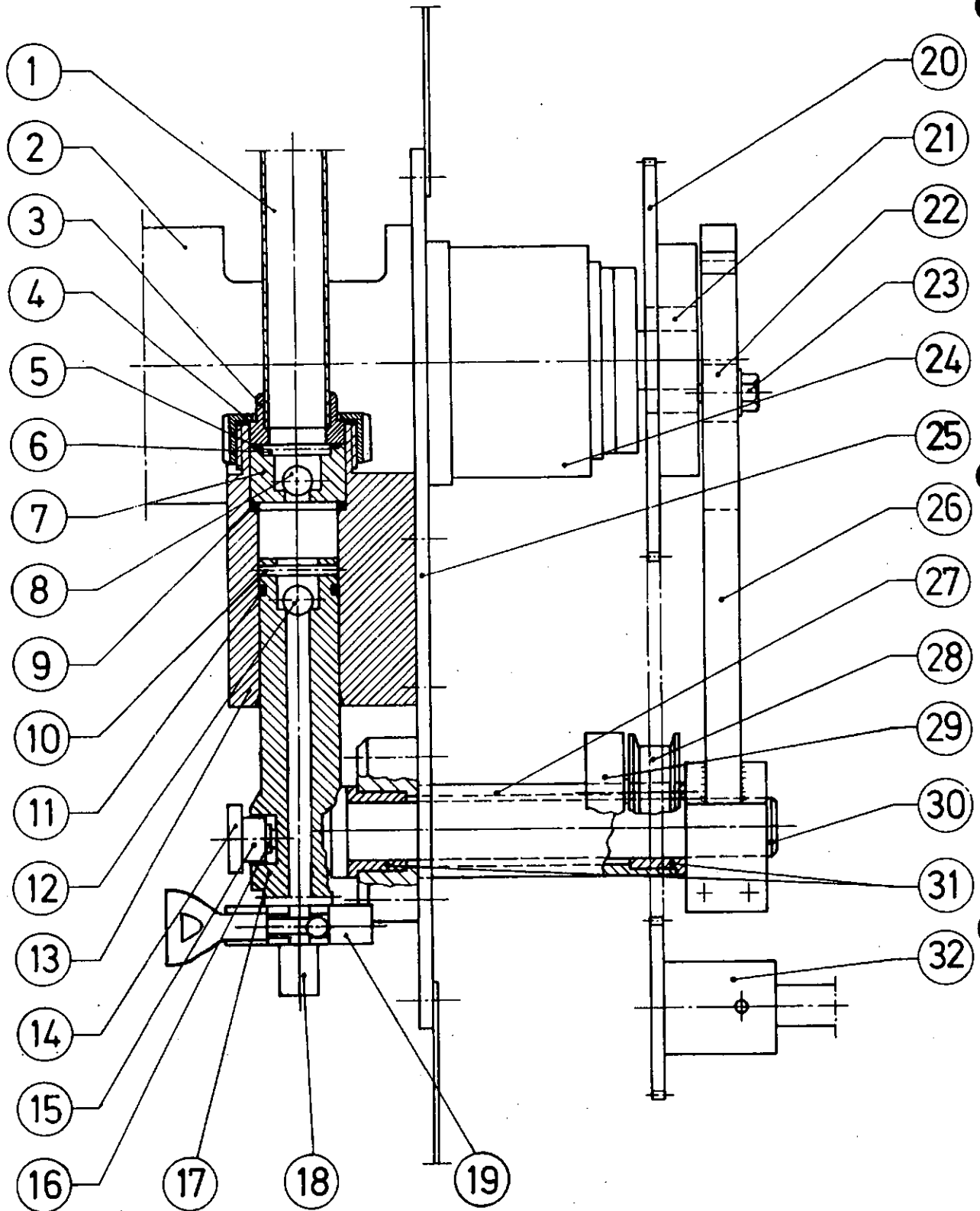

Tolerancer, der ikke angives ved spåntegende bearbejdn. klipping eller stansning		Målestok 1:2,5	TECHNOHOY		Date 13.01.87.
		First angle projection ISO method E	AARHUS	DENMARK	Tegn S.K.
			Driving arrangements for pumps Antrieb für Pumpen		Godk.
					D 5984
Basismål	Tol.	T. Kori	Rett.		D 9406
(1)	6 ±0.1		Rett.		
(6)	30 ±0.2		Rett.		
(30)	120 ±0.3		Rett.		
(120)	315 ±0.5		Rett.		
(315)	1000 ±0.8		Rett.		
(1000)	2000 ±1.2		Rett.		
(2000)	4000 ±2.0	Materiale	Maskintype MF	Rett.	

TECHNOHOY

DESCRIPTION AND MAINTENANCE

MF 50

IV-04

22

TN

THE MIX PUMP AND DRIVING ARRANGEMENT. DRAWING D 9406

The function of this pump is straight forward. Power from the oscillating shaft 30 is transmitted to the piston 17 through the yoke 14. The two stainless steel balls 8 and 12 are acting as suction- and discharge valves. The inlet port for mix, is connected to the mix supply tank by means of a rubber or synthetic hose. The tank should be placed higher than the pump, in order to secure positive pressure at the inlet. The outlet port is connected to the sanitary tee 8 through the pipe 10 on C 16440.

To take the pump apart, remove the pin. Push back the yoke 14 AND REINSERT THE PIN. THIS IS IMPORTANT, as the parts could be damaged, if the pump motor should be started accidentally. After the piston has been pulled out, the ball retaining pin 10 and the ball 12 can easily be removed. Then remove the union nut 4, which keeps the cylinder head 7 and the top flange 3 in place.

When reassembling the pump be sure, that both of the synthetic rollers 15 are in place.

The pump ratio is adjustable. See later.

The driving arrangement is of a solid design and straight forward.

The power is transmitted from the rotating chain wheel 32 to the chain wheel 20 attached on the ice cream pump.

The oscillating arm 26 transmits the power to the mix pump according to the preset pump ratio.

The chain is tightened by moving the arm 29.

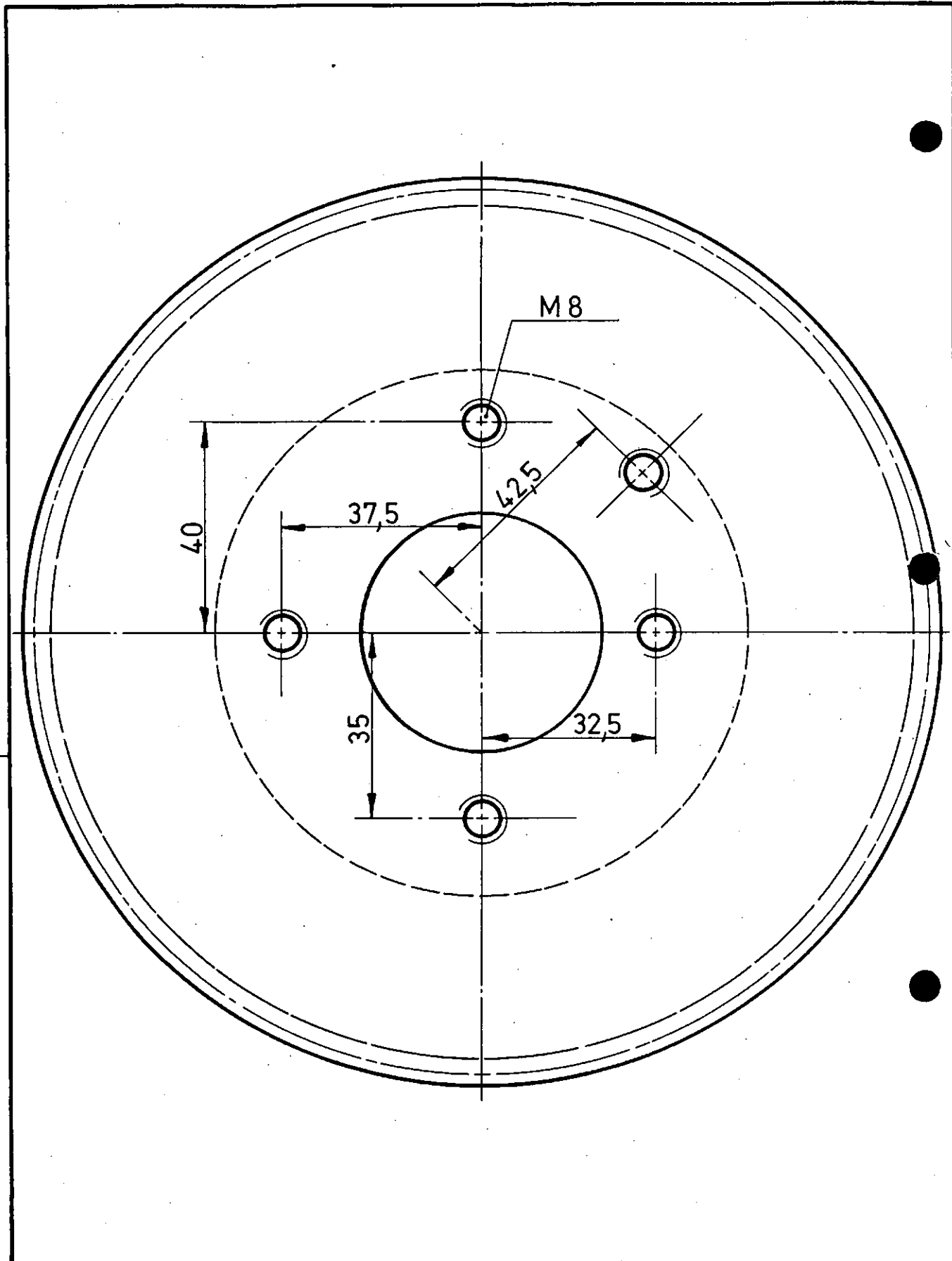

Tolerancer, der ikke angives ved spåntagende bearbejdn., klipping eller stansning

Målestok
1:1

TECHNOHOY

Dato **7.11.83.**

AARHUS

DENMARK

Tegn. **DSM.**

Basismål	Tol.
(1)	6 ±0,1
(6)	30 ±0,2
(30)	120 ±0,3
(120)	315 ±0,5
(315)	1000 ±0,8
(1000)	2000 ±1,2
(2000)	4000 ±2,0

First angle projection
ISO method E



CHAIN WHEEL KETTENRAD

Godk.

T. Kort

Retl.

Retl.

Retl.

Materiale **St. 37.**

Maskintype **MF**

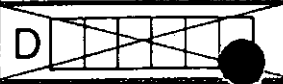

D **6004**

TECHNOHOY

DESCRIPTION AND MAINTENANCE

MF 50

IV-05

23

TN

THE ICE CREAM PUMP

Please read the pump manual for the ice cream pump.

ADJUSTING THE PUMP RATIO, DRAWING D 6004

To get the required overrun of the finished product, there are two possibilities of adjustment. One is already mentioned : Adjusting the air pressure by the knob CHANNEL-1 on the flowmeter. The air pressure is shown on the gauge 22.

If the air pressure is too low or too high to get the required overrun, you can change the pump ratio by unscrewing the INA curve roller and remove it to one of the four other positions, see drawing D 6004.

In this way the pump ratio can be changed between 5 positions.

Equivalent to 42,5 mm distance is pump ratio app. 1:1,15

Equivalent to 40,0 mm distance is pump ratio app. 1:1,25

Equivalent to 37,5 mm distance is pump ratio app. 1:1,35

Equivalent to 35,0 mm distance is pump ratio app. 1:1,45

Equivalent to 32,5 mm distance is pump ratio app. 1:1,60

TECHNOHOY

DESCRIPTION AND MAINTENANCE

MF 50

IV-06

24

50, TP

The accurate value of the pump ratio is depending of the recipe of the mix, pressure in the freezing tube, conditions of the pumps, so within a range of 5 values the desired result can be found.

When the pump ratio is correctly adjusted, further adjustments are unnecessary.

In case of problems with the pump ratio - please contact Technohoy.

REFRIGERATION COMPONENTS for Diagram D 16441

1	Compressor	Pos. 1	Prestcold L 300/0062
1	Evaporator	Pos. 2	Technohoy
1	Condenser	Pos. 3	Roller B3
1	Solenoid Valve	Pos. 4	Danfoss EVR 6
1	Heat Exchanger	Pos. 5	Searle 120 XS
1	Heat Exchanger	Pos. 6	Searle 120 XS
1	Back press.reg.valve	Pos. 7	Danfoss KVP 22
1	Oil Separator	Pos. 8	Danfoss OUB 4
1	Pressure control	Pos. 9	Danfoss KP 5
1	Sight glass	Pos. 10	Danfoss SGI 10
1	Therموالve	Pos. 11	Danfoss TY 2 No.3
1	Closing valve (Freon)	Pos. 12	Danfoss BML 10
1	Solenoid Valve	Pos. 13	Lucifer 121 K 03
1	Filter	Pos. 14	Danfoss DX 165
1	Water regulat. valve	Pos. 15	Danfoss WVFX 15
1	Pressure gauge	Pos. 16	Tempress Ref.No. R 11700
1	Sight glass	Pos. 17	Danfoss SGI 6
1	Pressure gauge HP	Pos. HP	Tempress Ref.No. R 14168
1	Pressure gauge LP	Pos. LP	Tempress Ref.No. R 14364

Refrigerant: Freon R 502

The Condenser Pos. 3 carries a label indicating the Freon charge.

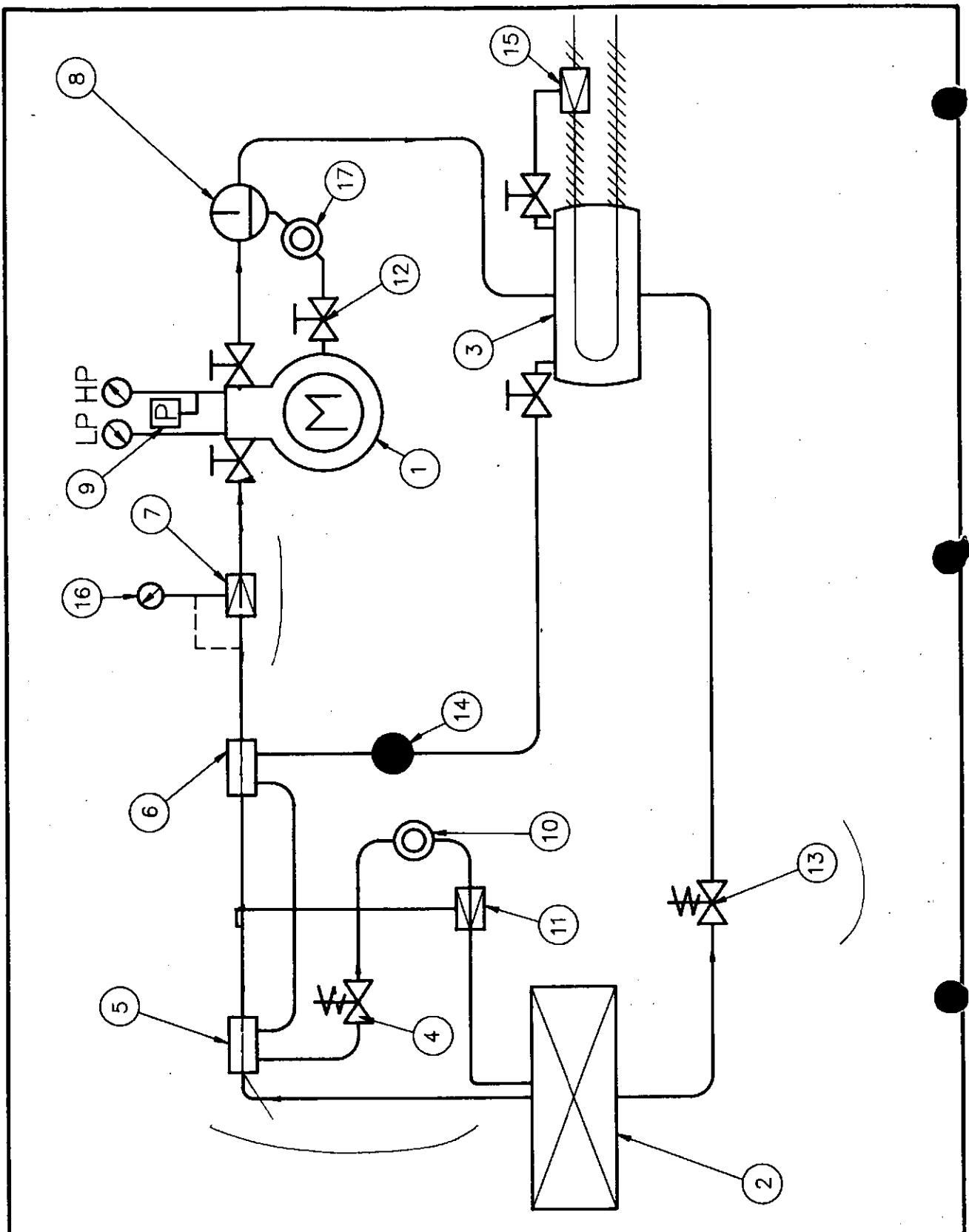

Tolerancer ifølge DS 2075, hvor intet andet er angivet.		Antal	Stykklistenr.	Maskine	Evt. bem.	
Afkortningsmål:		<h1>TECHNOHOY</h1> CARL HOYER A/S AARHUS - DENMARK			Skala	Tegn. sc
Antal	Dimension				1:1	Dato
R-502 Diagram		<div style="border: 1px solid black; width: 100%; height: 100%; display: flex; align-items: center; justify-content: center;"> D16441 </div>				
Materiale						

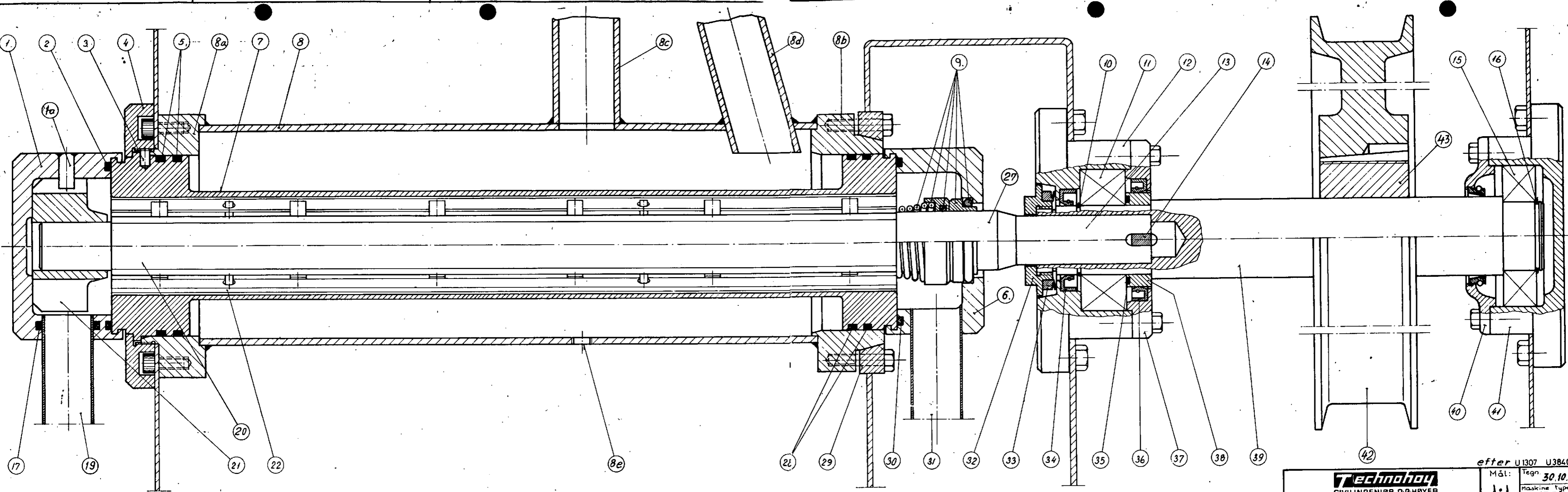

Technohoy CIVILINGENIØR OG HØYER AARHUS - DANMARK	efter U1307 U3840	
	Mål: 1:1	Tegn: 30.10.79 W
Frysecylinder med hovedtræk		erstatter U1307 U 5437

Firma:

Technohoy
 CIVILINGENIØR O.G. HØYER
 AARHUS · DANMARK

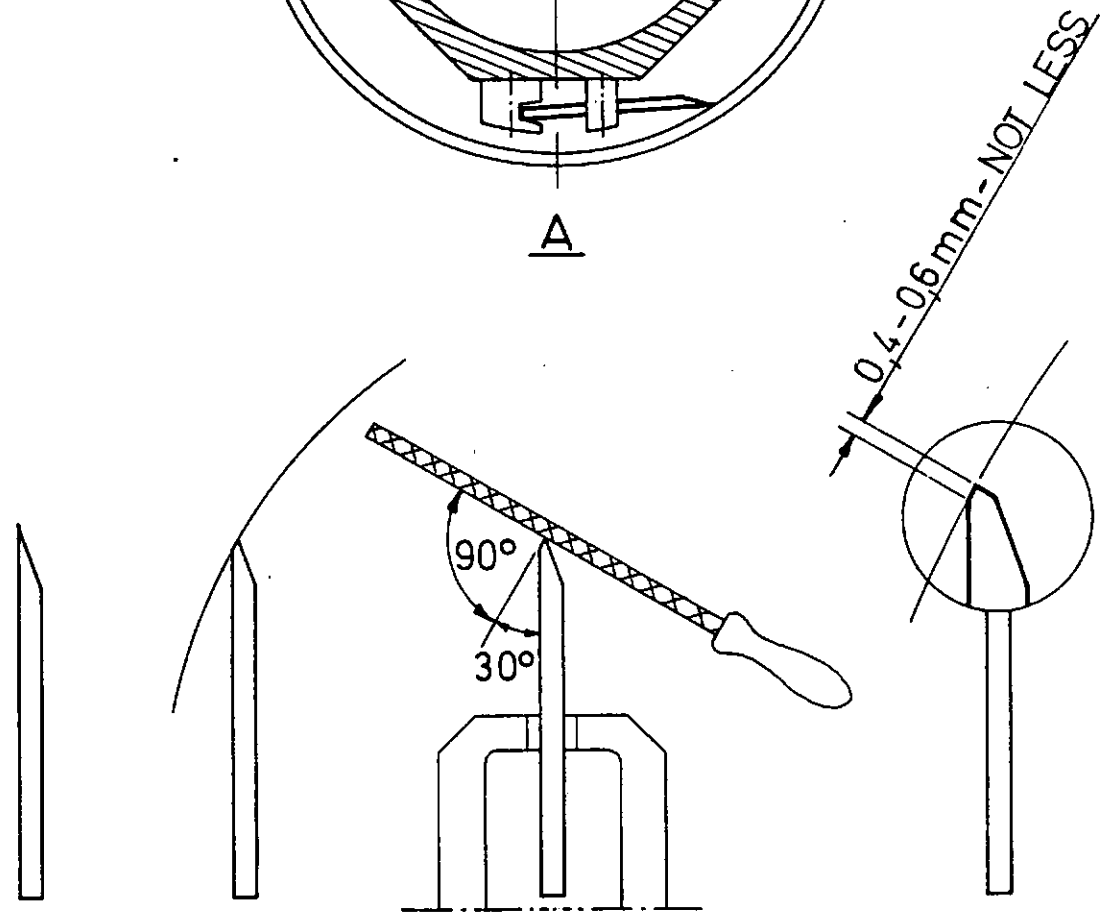
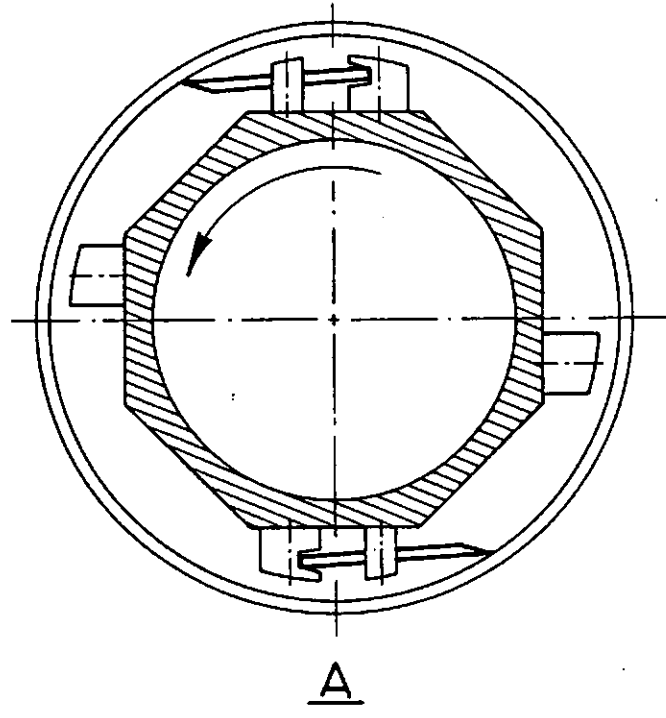

mm

Alle mål uden tolerance ±

NEW WORN-IN RECONDITIONING READY FOR
USE

erst. af D4058	Materiale	Model nr.	Lager nr.	Målforhold	Tegn.	78.06.08.
					Kont.	R
Genstand: RECONDITIONING WORN SCRAPER BLADES					Tg. nr.	D 3140

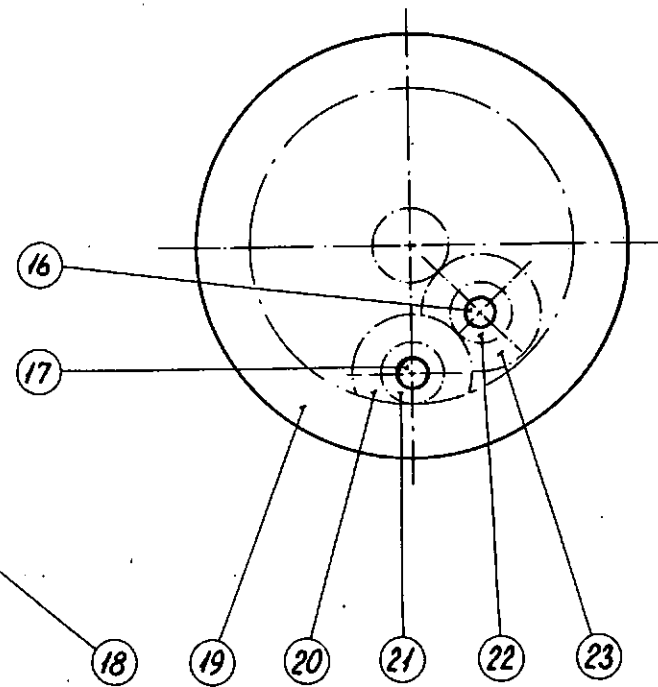
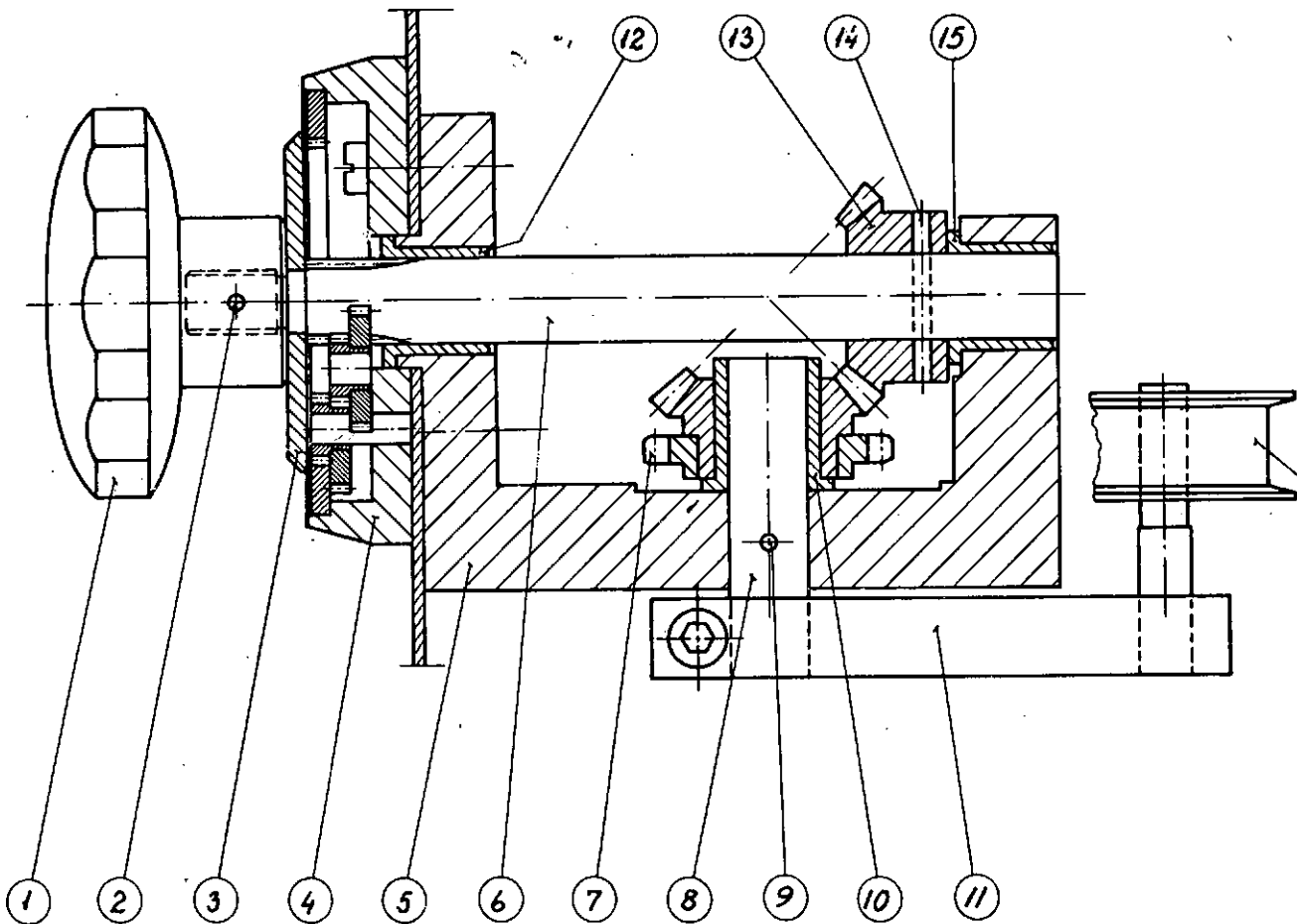

Stk.	Genstand	Mrk. nr.	Tegn. nr.	Materiale	Model nr. Lager nr.	Vægt
TECHNOHOL CIVILINGENIØR OG HØYER AARHUS - DANMARK				Målfarhold	Tegn.	30.1.78
					Kont.	R
					Normpr.	
Hast. regulering af pumper.				(Erstatning for:)		
				C 2954		
				(Erstattet af:)		

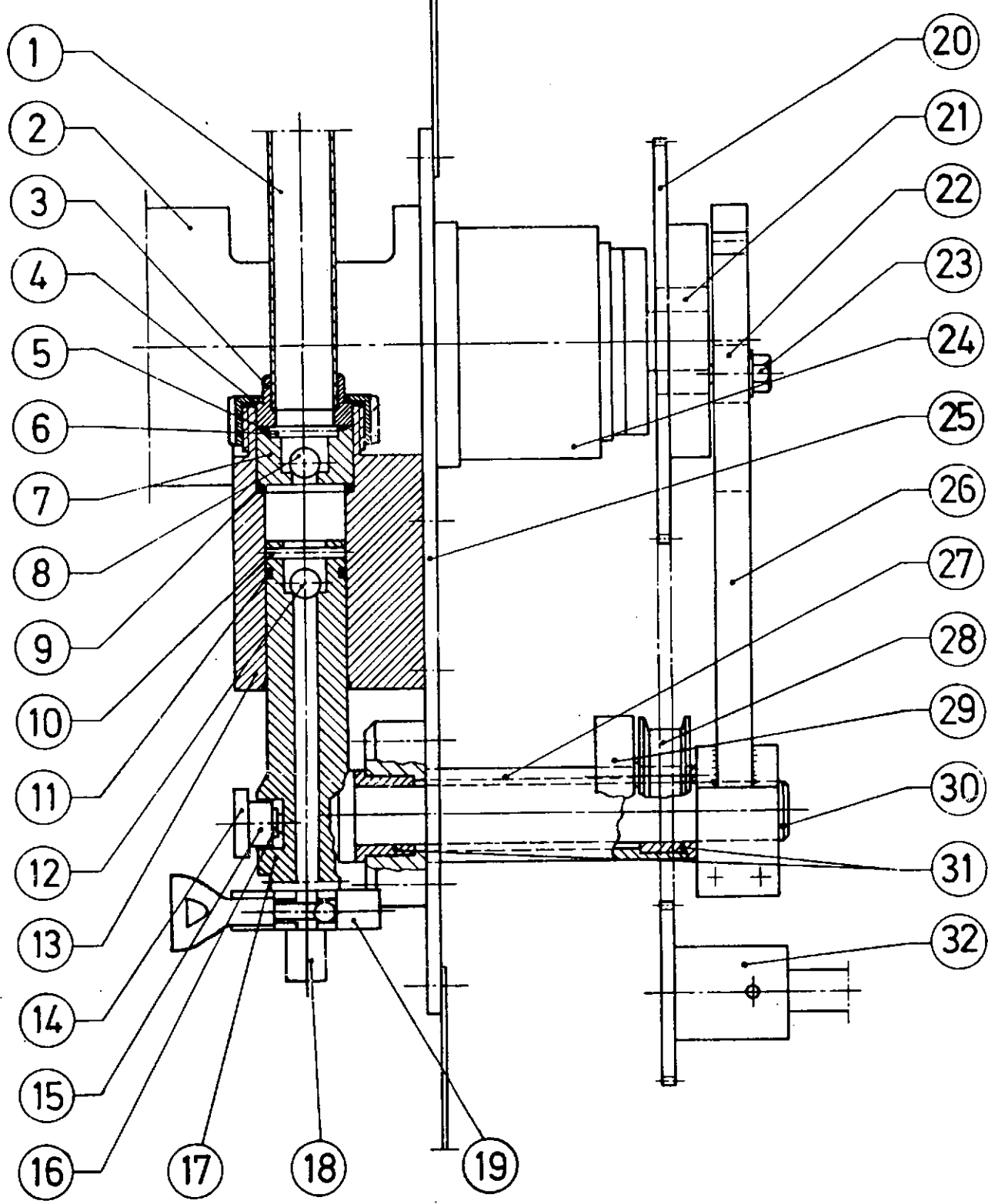

Tolerancer, der ikke angives ved spåntagende bearbejdn, klipping eller slansning		Målestok 1:2,5	TECHNOHOY		Dato 13.01.87.																		
		AARHUS	DENMARK		Tegn: S.K.																		
<table border="1" style="width: 100%; border-collapse: collapse;"> <thead> <tr> <th style="width: 15%;">Basismål</th> <th style="width: 15%;">Tol</th> <th style="width: 15%;">First angle projection ISO method E</th> </tr> </thead> <tbody> <tr> <td>(1)</td> <td>6 ±0.1</td> <td rowspan="6" style="text-align: center;"> </td> </tr> <tr> <td>(6)</td> <td>30 ±0.2</td> </tr> <tr> <td>(30)</td> <td>120 ±0.3</td> </tr> <tr> <td>(120)</td> <td>315 ±0.5</td> </tr> <tr> <td>(315)</td> <td>1000 ±0.8</td> </tr> <tr> <td>(1000)</td> <td>2000 ±1.2</td> </tr> <tr> <td>(2000)</td> <td>4000 ±2.0</td> <td></td> </tr> </tbody> </table>		Basismål	Tol	First angle projection ISO method E	(1)	6 ±0.1		(6)	30 ±0.2	(30)	120 ±0.3	(120)	315 ±0.5	(315)	1000 ±0.8	(1000)	2000 ±1.2	(2000)	4000 ±2.0		Driving arrangements for pumps Antrieb für Pumpen		Godk
Basismål	Tol	First angle projection ISO method E																					
(1)	6 ±0.1																						
(6)	30 ±0.2																						
(30)	120 ±0.3																						
(120)	315 ±0.5																						
(315)	1000 ±0.8																						
(1000)	2000 ±1.2																						
(2000)	4000 ±2.0																						
		T. Kort	Retl.	D 5984																			
Materiale		Maskintype MF	Retl.	D 9406																			
			Retl.																				

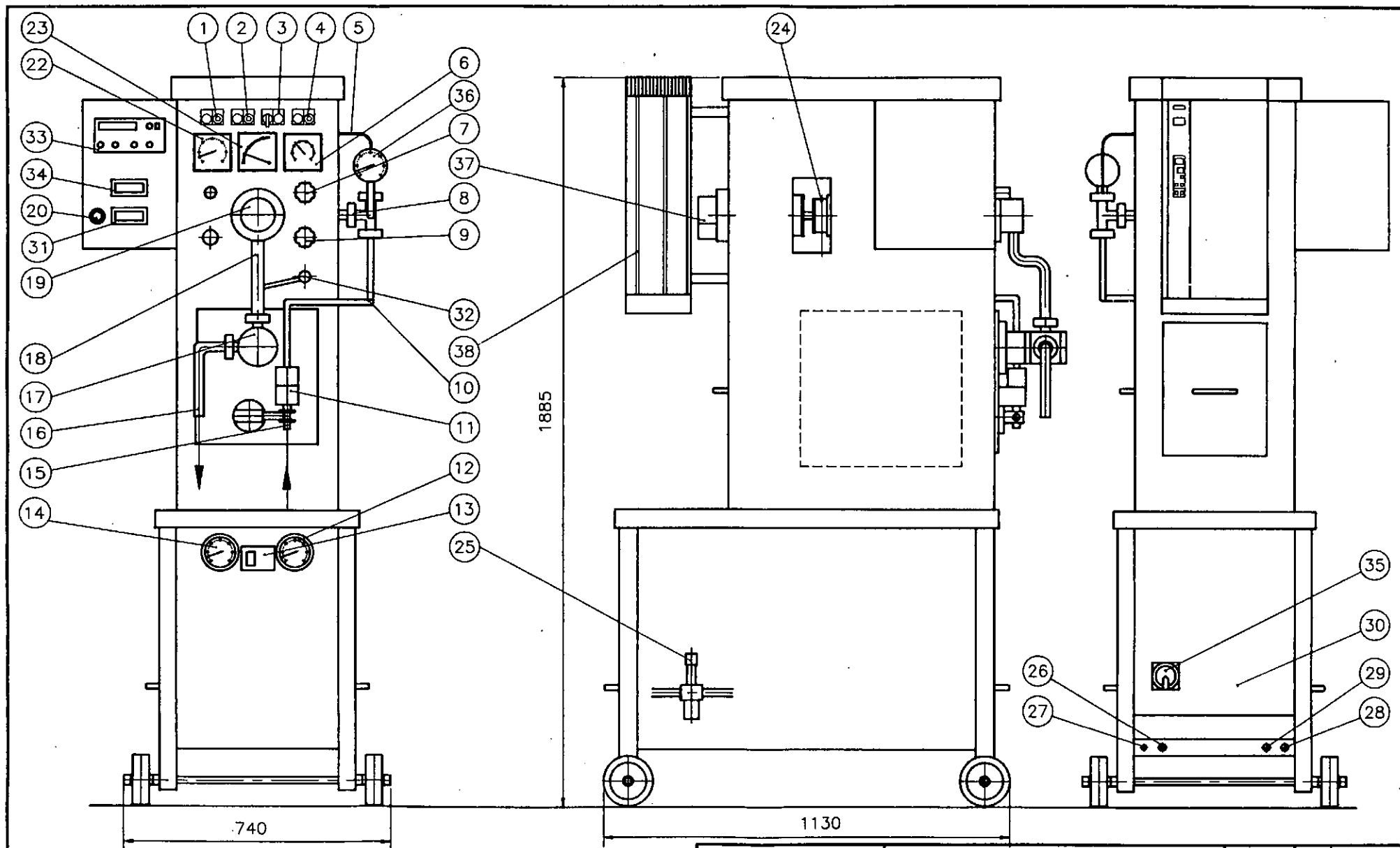

Afkortningsmål:		TECHNOHOY CARL HOYER A/S AARHUS - DENMARK	Skala	Tegn.	JA
Antal	Dimension				
		MF 50			C 10813
		Materiale	Maskestype	MF	C 16440

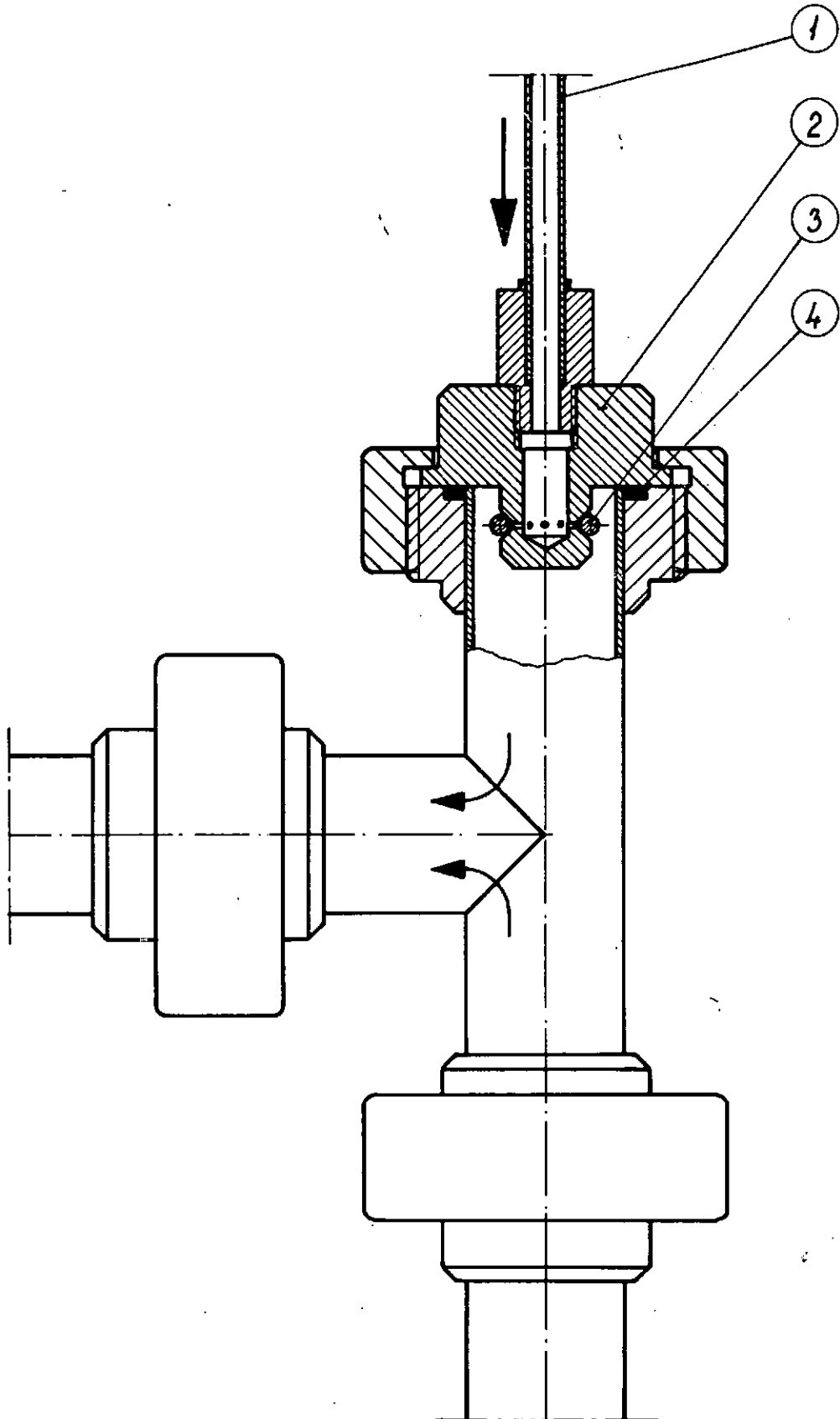

mm

Alle mål uden tolerance ±

	Materiale	Model nr.	Lager nr.	Målforskel	Tegn.	78.06.15.
				1:1	Kont.	R
	Genstand:			Teg. nr.		
	T-stykke m/kontraventil.			D 3141		

(2/8) 2°) Système de régulation pompes (folios 4/8) Suivant plan C2954

Pignon	Rep 7
Engrenage	Rep 13
Engrenage	Rep 13.

3°) Cylindre / Rotor (folios 5/8) Suivant plan U5437

Joint torique	Rep 5
Couteaux	Rep 22
Palier avant	Rep 21
Garniture complète	Rep 9

4°) Système de forçonnement (folios 6/8) Suivant plan D 3141

Joint torique	Rep 3
Buse	Rep 2

5°) Pompe FP1 (folios 7/8)

Joint torique	Rep 7.
Grain carbone	Rep 9.
Grain carbone	Rep 5
Joint	Rep 3

6°) Pompe (folios 8/8) Suivant plan D 9406

Piston complet	Rep 17/12/10
----------------	--------------

AF50

BRAMMER 

318

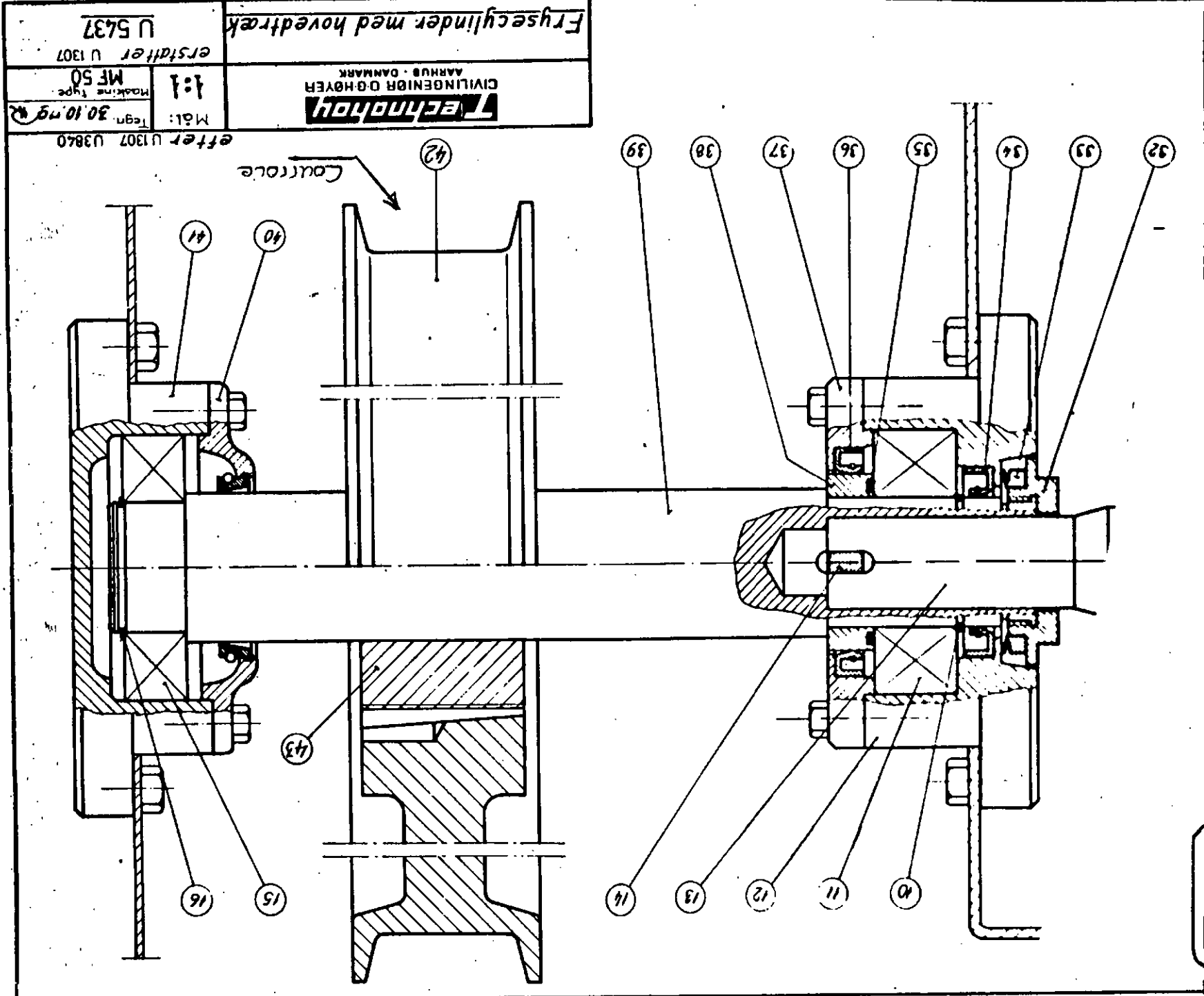

LIBELLE: Entainment roller
ORIGINE: N° PLAN: 57 21 19.
FAMILLE: 57
SOUS FAMILLE: 21
SCHEMA: 19.

4/8

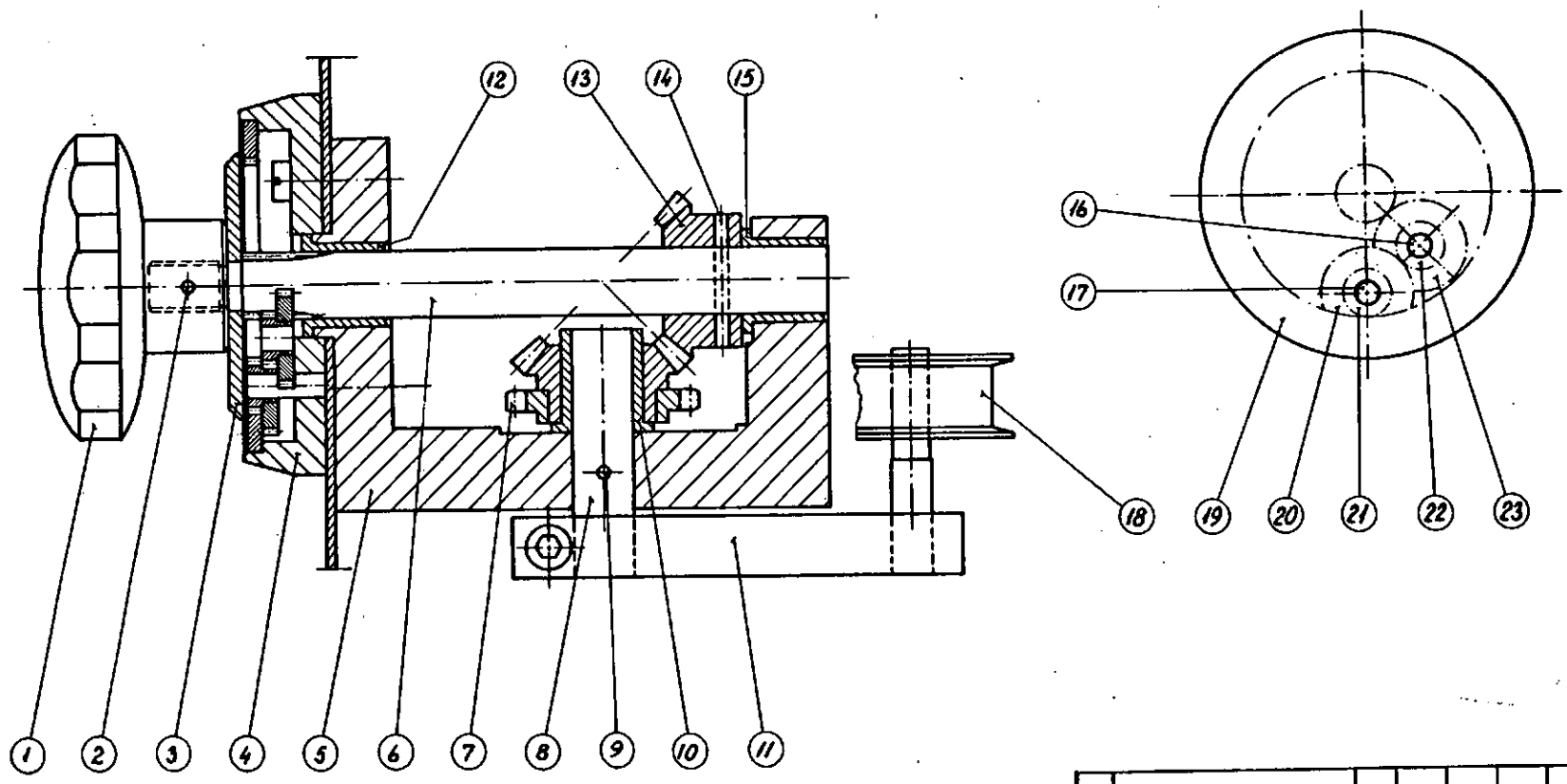

Sch.	Genstand	Arch. nr.	Tegn. nr.	Skæbetele	Inden nr. Lager nr.	Vægt
TECHNOLOY CIVILINGENIØR OG HØYER AARHUS - DANMARK		Målestok	Tegn. 30.1.78			
		1:1	Kont. R			
		(Erstatning for:)				
Hast. regulering af pumper		C 2954				
		(Erstatning af:)				

HAM (00) 16 27 27

LIBELLE: *Systeme regulation pompes.* FAMILLE SOUS FAMILLE 57 12 A. SCHEMA

ORIGINE: *c.* N° PLAN:

58

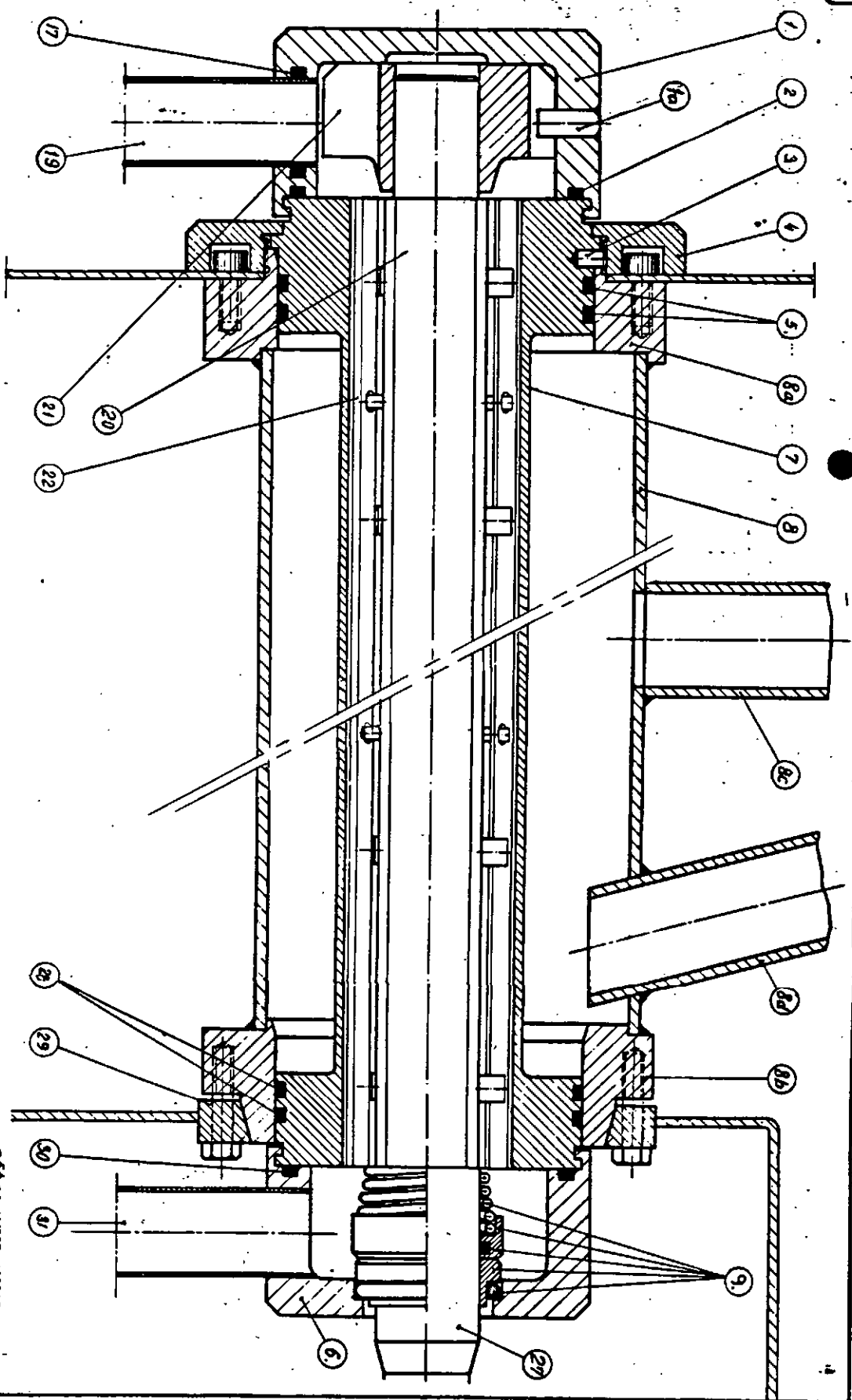

TECHNIPOLY
 CIVILINGENIØR OG HØYER
 ÅRHUS · DANMARK

efter U1307 U3840
 Mål: 1:1
 Tegningstype: MF 50
 erstatter U1307
 U 5437

Frysecylinder med hovedtræk

LIBELLE:	Cylindre / Piston	FAMILLE	SOUS FAMILLE	SCHEMA
		57	13	A.
ORIGINE:	N° PLAN:			

6/8

TECHNOHOL
 CIVILINGENIØR OG HØYER
 AARHUS · DANMARK

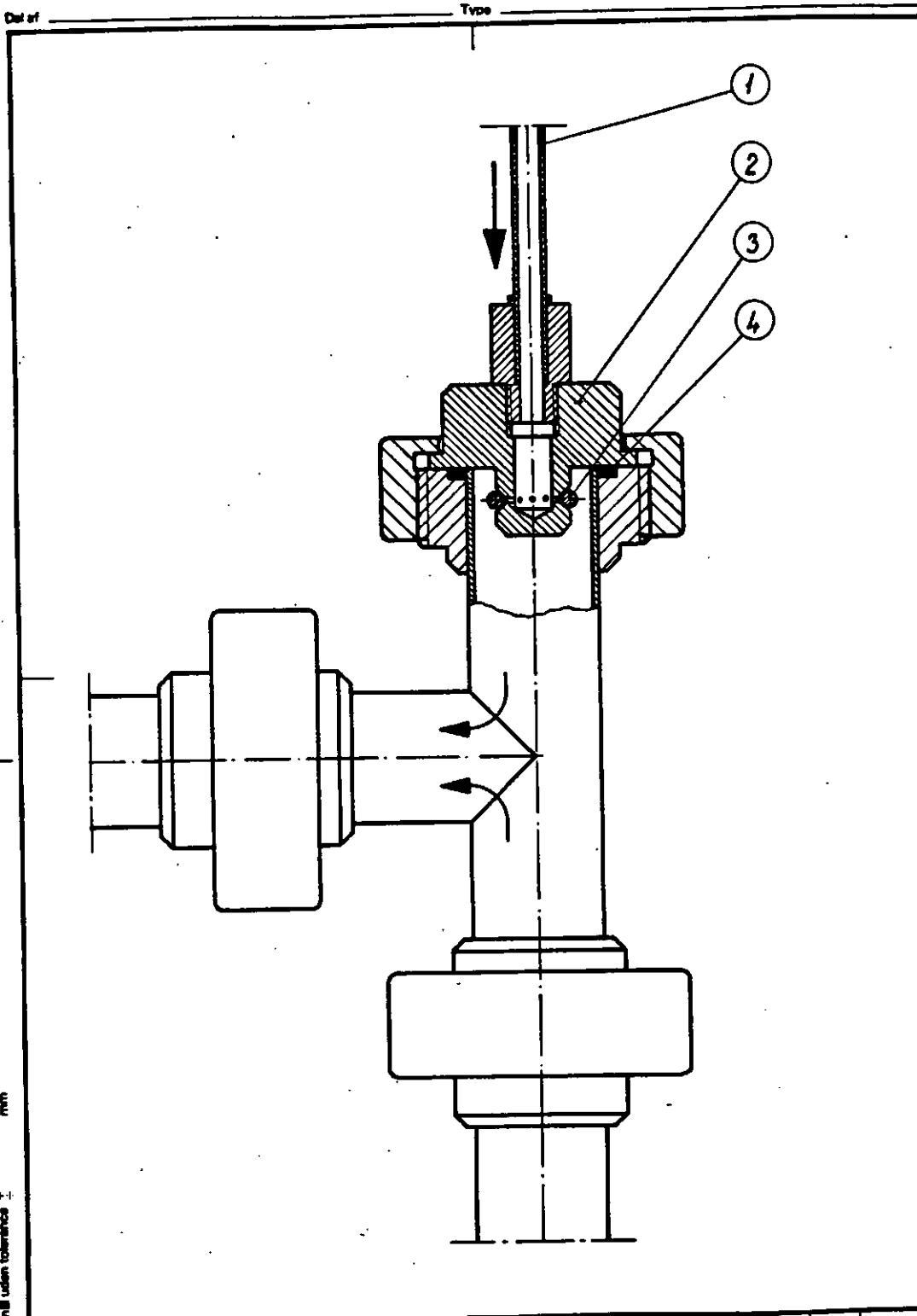

Alle mål uden tolerance ±
 mm

	Materiale	Model nr.	Lager nr.	Målforhold	Tegn.	78.06.15.
				1:1	Kont.	R
Genstand:				Teg. nr. D 3141		
T-stykke m/kontraventil.						

NM 1091 16 27 27

LIBELLE:	Systeme de forsejnement.	FAMILLE	SOUS FAMILLE	SCHEMA
		57	15	A.
ORIGINE:	N° PLAN:			

7/8

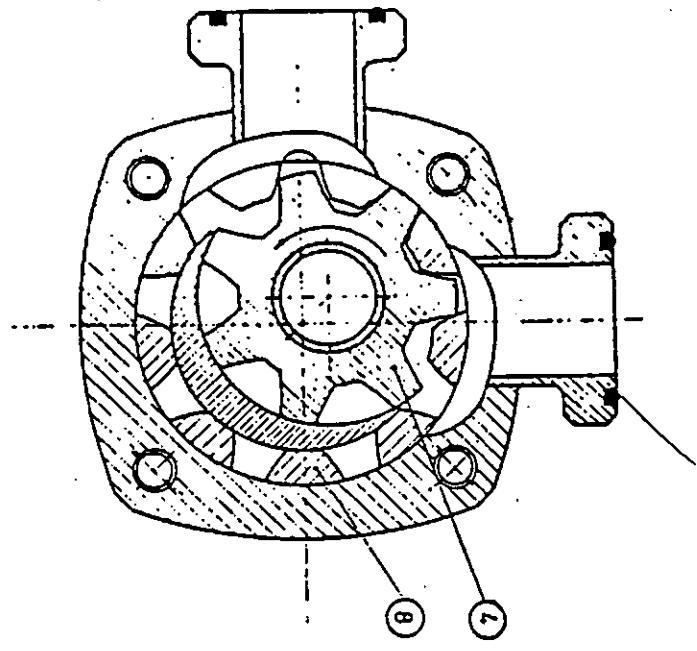

SPLIT R:R

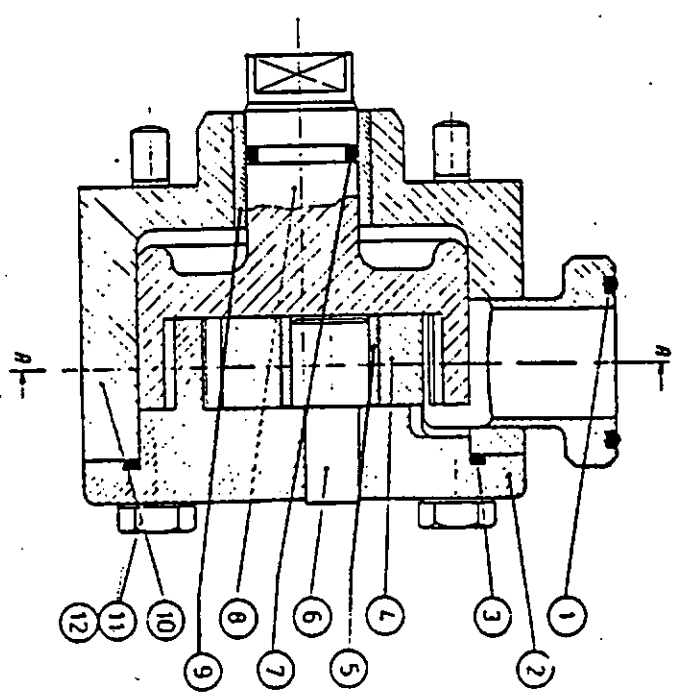

Technohoy
 CARL HOYER AS
 Axel Kiær Vej 30
 DK-8270 Aarhús - Holbæk

LIBELLE:	FAMILLE	SOUS FAMILLE	SCHEMA
POMPE HOYER FP 1	44	21	A.
ORIGINE: FREEZER-TECHNOHOY.	N° PLAN:		

8/8

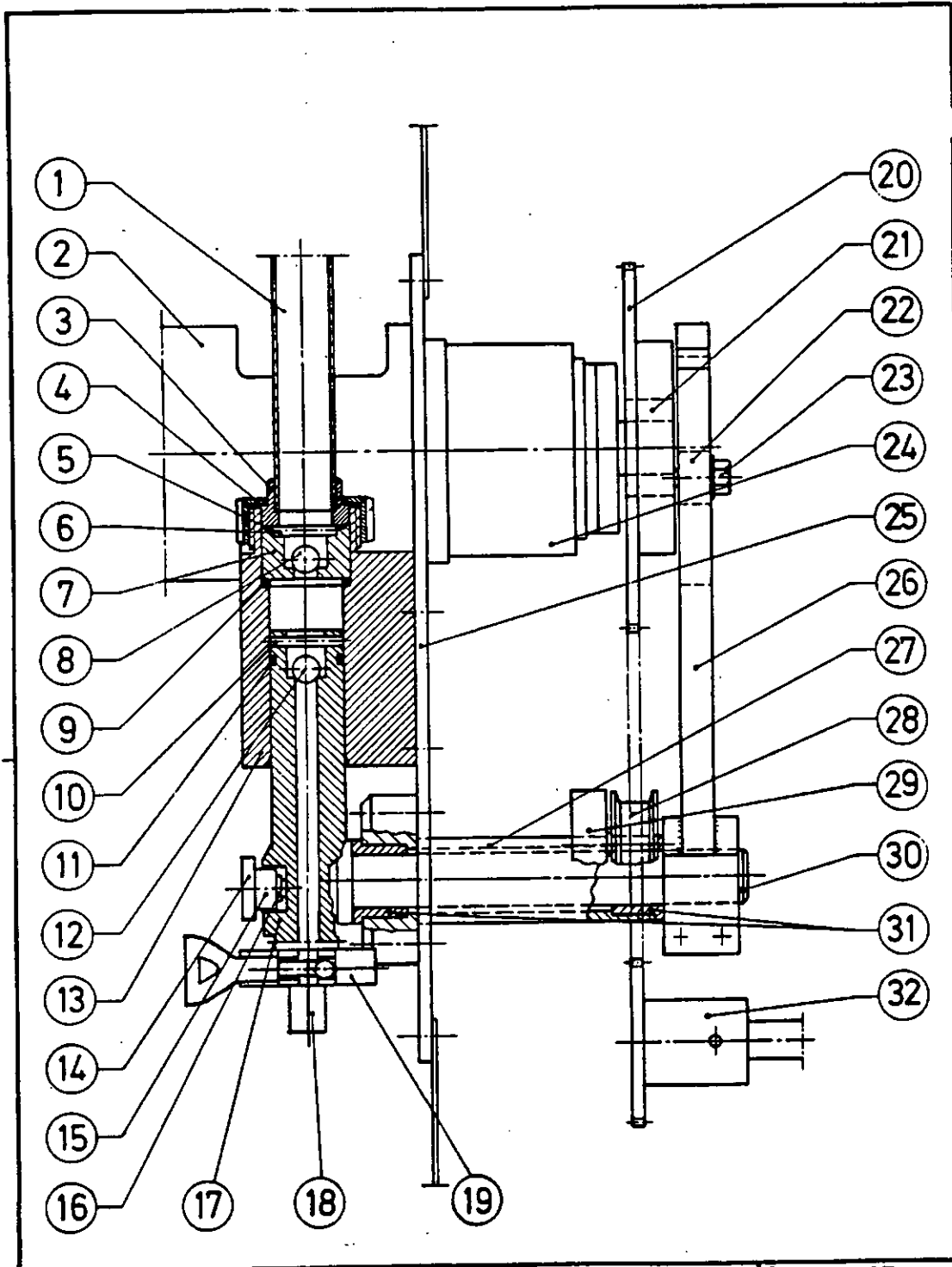

Tolerancer, der ikke angives ved spændende bearbejdning slipning eller stansning		Målestok 1:25	TECHNOHOY		Date 13.01.87
		First angle projection ISO method E	AARHUS	DENMARK	Tegn S.K.
			Driving arrangements for pumps Antrieb für Pumpen		Godk
Basismål	Tol				
(1)	6 ±0.1				
(6)	30 ±0.2				
(30)	120 ±0.3				
(120)	315 ±0.5				
(315)	1000 ±0.8				
(1000)	2000 ±1.2				
(2000)	4000 ±2.0				
		Materiale	Maskestykke MF		

H.M. (09) 162727

LIBELLE:	POMPE HOYER TECHNOHOY.			FAMILLE	SOUS FAMILLE	SCHEMA
				44	22	A.
ORIGINE:	Greener TECHNOHOY.		N° PLAN:			

Contents

Spare parts	2
When you order spare parts.....	2
Pieces de rechange.....	2
Lors du passage de votre commande.....	2
Description of Function, See diagram C T58397	3
Description de Fonctions, Voir plan C T58397	3
The mix pump, Drawing C T33610	4
Pompe à mix, Voir plan N° C T33610.....	5
Ice cream hose valve, Drawing no C T33537	6
Vanne à crème glacée, Voir plan N° C T33537.....	7
Spare parts lists / Liste de pièces de rechange.....	8
T58397	9
T33537	10

Spare parts

When you order spare parts

When ordering spare parts for your machine, please always state:

- Machine type
- Serial number
- Drawing number
- Position number
- Part number.

Pieces de rechange

Lors du passage de votre commande

Lors du passage de votre commande de pièces de rechange, veuillez indiquer :

- Le type de machine
- Le numéro de série
- Le numéro du plan, si possible
- Le numéro de position
- Le numéro de la pièce commandée



**WCB
Ice Cream**
An Alliance Company

Graham Bells Vej 6

DK - 8200 Aarhus N

Denmark

Telephone: + 45 87 41 20 00

Telex: + 45 87 41 20 01

Description of Function, See diagram C T58397

The ice cream mix is metered into the freezing cylinder by a mix pump, and a constant flow of air is fed in together with the mix. During the passage through the cylinder, the air is whipped into the mix by the action of a rotating rotor.

Air/mix in the freezing cylinder will give some of its heat to the refrigerant in the surrounding cooling jacket, with which the air/mix is cooled down to cold ice cream and the refrigerant evaporates to condense later in the condenser.

This change of condition for the refrigerant takes place at a temperature that depends on the actual evaporating pressure in the cooling jacket.

The evaporating pressure and temperature is regulated on the front of the freezer.

Hardened scraper blades of the best quality, hinged to the rotor, scrapes off the ice cream, continuously as it freezes on to the inside cylinder wall. Whipping and freezing takes place under air pressure, which can be regulated to obtain the desired overrun.

The freezer is mounted with a cream pump that will forward the finished product from the outlet of the cylinder to the discharge piping.

Description de Fonctions, Voir plan C T58397

La pompe à mix envoie le mix dans le cylindre de congélation. Un débit constant d'air est envoyé dans le cylindre de réfrigération. Lors du passage dans le cylindre de congélation, l'air est mélangé au mix grâce à un racleur.

Par régénération, le mélange air/mix donne un peu de sa chaleur au réfrigérant circulant dans l'enveloppe du cylindre. Le réfrigérant refroidit le mélange air/mix qui se transforme en crème glacée. Par la suite, le réfrigérant s'évaporerait dans le condenseur.

Les conditions du réfrigérant se modifient à une température qui dépend de la pression réelle d'évaporation dans l'enveloppe de refroidissement.

La pression d'évaporation et la température se règlent sur le panneau avant du freezer.

Des raclettes de la meilleure qualité, montées sur le racleur, raclent continuellement la crème glacée au fur et à mesure qu'elle se congèle sur les parois intérieures du cylindre. Le mélange et la congélation se font sous pression qui peut être réglée pour obtenir le foisonnement voulu.

Le freezer est équipé d'une pompe à crème glacée qui envoie le produit fini de l'orifice de sortie du cylindre au tuyau d'évacuation.

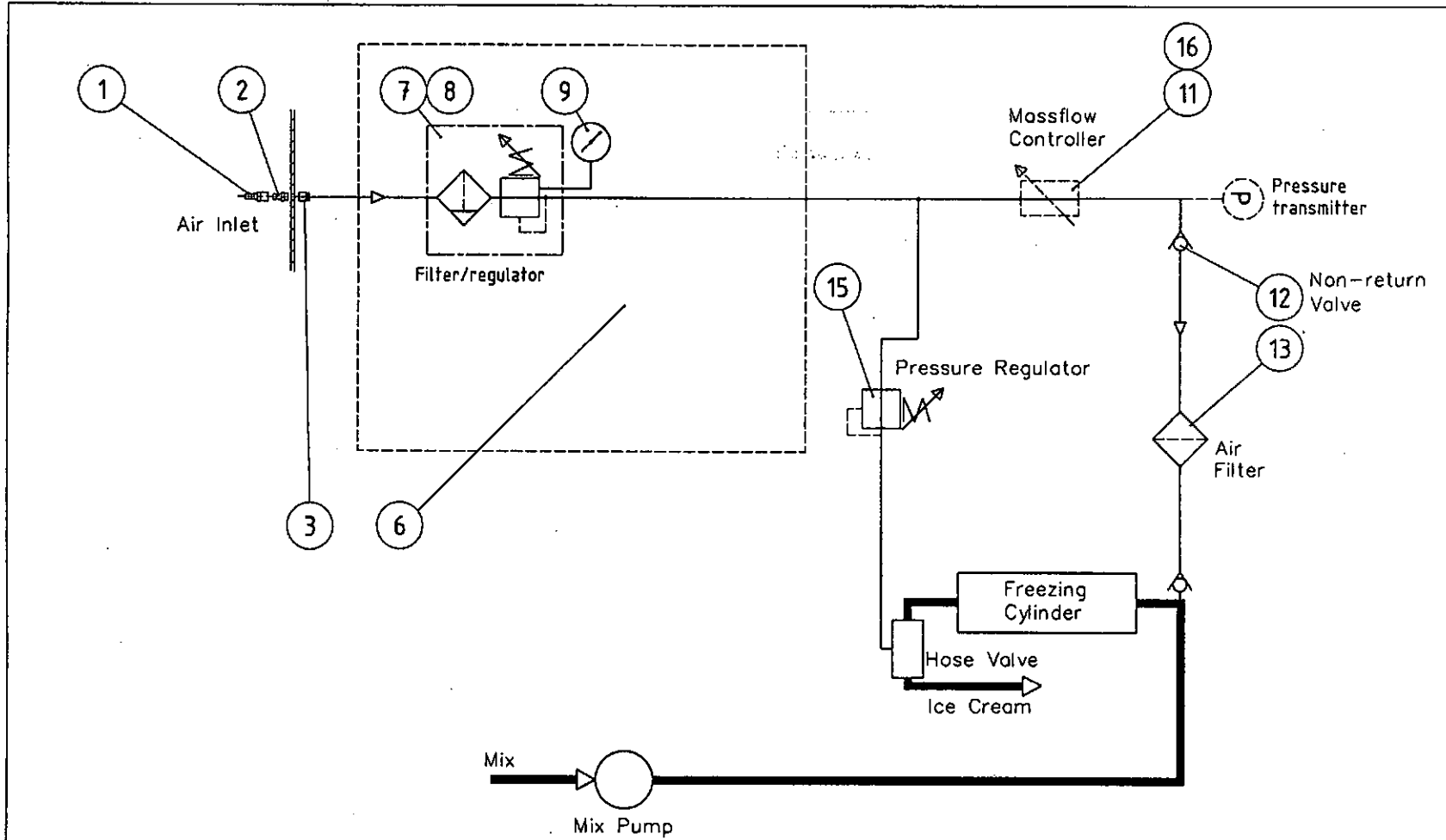

Revision	1	esc	Ändringen Pos. 4 og 5 er fjernet.		Revisionsdato	17.0105
WCB Ice Cream Waukesha Cherry-Burrell					No. of	Drawn by: Esc
					Scale	Date: 15-09-2006
Luftsystem for stempel/slange m massflow. u manomet					Machine:	Approved by:
					Drawing Size: A3	DWG drawing No.: T55302
Do not copy or distribute to third party without approval by WCB Ice Cream A/S, Graham Bølle Vej 8, DK-8200 Århus N					Scale:	1:1
					Drawing No.:	C T58397

The mix pump, Drawing C T33610

The mix pump is a piston pump with a reciprocating piston.

The function of this pump is simple. Power from the oscillating shaft 12 is transmitted to the piston 9 through the yoke 10.

The two stainless steel balls 6 are acting as suction and discharge valves. The inlet port 13 for mix is connected to the mix supply tank by means of a rubber or synthetic hose. The tank should be placed higher than the pump, in order to secure positive pressure at inlet. The outlet port is connected to the sanitary tee through a pipe.

To take the pump apart, remove the pin 11.

Push back the yoke 10 and reinsert the pin. This is important, as the parts could be damaged, if the pump motor should be started accidentally. After the piston has been pulled out, the ball retaining pin 9 and the ball 6 can easily be removed. Then remove the union nut 2, which keeps the cylinder head 4 and the cover 1 in place.

When reassembling the pump, be sure that both synthetic rollers 16 are in place.

Pompe à mix, Voir plan N° C T33610

La pompe à mix est une pompe à piston avec piston à mouvement alternatif.

La fonction de cette pompe est très simple. La force de l'arbre oscillant, Pos. 12, est transmise au piston, Pos. 10, par la chape, Pos. 9.

Les deux billes en acier inoxydable, Pos. 6, fonctionnent comme vannes d'aspiration et de refoulement. L'orifice d'entrée 13, pour le mix est raccordé au tank d'alimentation de mix par un tuyau souple. Le tank doit être placé plus haut que la pompe de façon à assurer une pression positive dans l'orifice d'entrée. L'orifice de sortie est raccordé à la pièce en T par le tuyau.

Pour démontée la pompe, retirer la goupille, Pos. 11.

Pousser la chape, Pos. 10, et remettre la goupille en place. Ceci est très important, car les pièces peuvent être endommagées si la pompe est mise en route accidentellement. Après avoir sorti le piston, la bille retenant la goupille, Pos. 9, et la bille, Pos. 6, peuvent facilement être enlevées. Ensuite, enlever l'écrou-raccord, Pos. 2, qui tient la tête du cylindre, Pos. 4, et la bride, Pos. 1, en place.

En remontant la pompe, s'assurer que les deux rouleaux synthétiques, Pos. 12, sont en place.

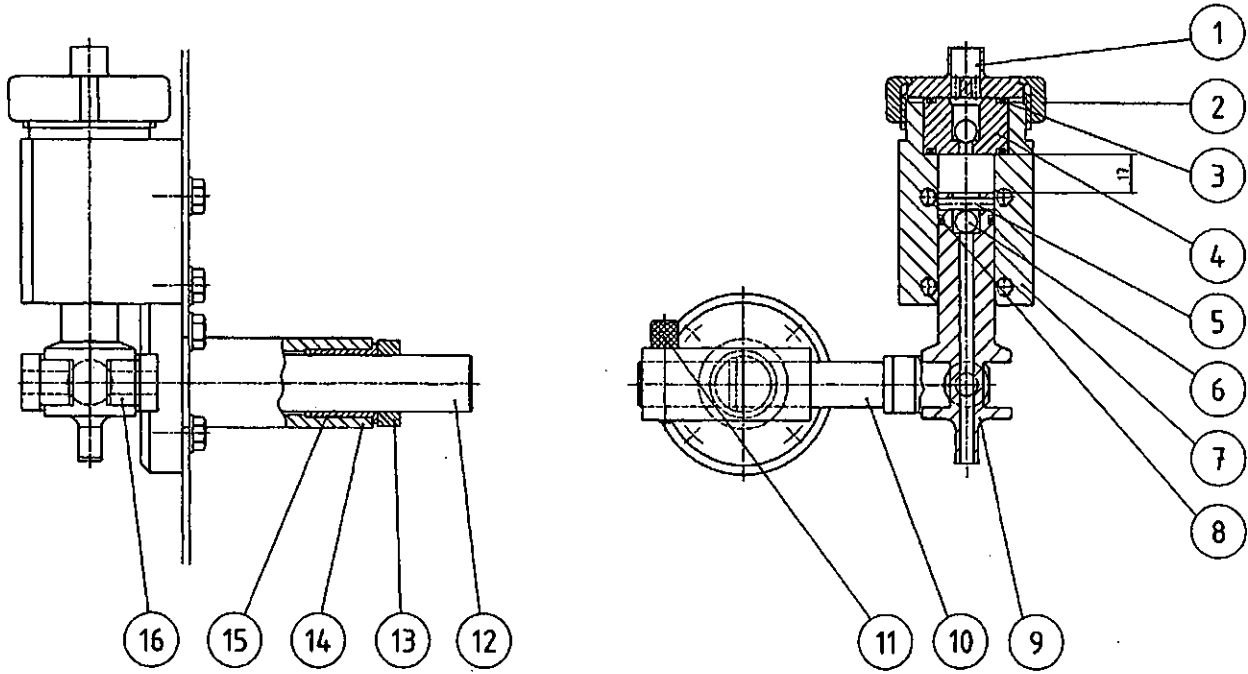

WCB Ice Cream A/S Waukesha Cherry-Burrell Stempelmixpumpe	No. of:	Drawn by:	OKR
	DCM:	Date:	27.08.99
	Machine:	Approved by:	
		Material:	
		Machine type:	MF 50/75
	Drawing Size	A3	Old drawing No.:
Scale:	1:2	Drawing No.:	C T33610
Tolerance according to DIN 2076 unless otherwise specified.			

Ice cream hose valve, Drawing no C T33537

The ice cream hose valve consists of a housing 5, which is closed by the end covers 2 and 7.

A silicone rubber hose 6 is attached between the end covers.

The air chamber between 5 and 7 is connected to the air pressure-regulating valve. The finished product comes from the freezing cylinder, through the ice cream pipe to the ice cream hose valve.

By means of the air pressure-regulating valve the pressure in the air chamber is adjusted, and thereby the silicone rubber hose is pressed. This causes a back-pressure in the freezing cylinder with reading at the air pressure gauge.

The ice cream outlet is connected to the hose valve nipple welded on pos. no. 7.

When using this system it is possible to work with a large range of overrun and cylinder pressure.

Vanne à crème glacée, Voir plan N° C T33537

La vanne consiste en un boîtier, Pos. 7, qui est fermé par les couvercles, Pos. 2 et 7.

Un tuyau en silicone, Pos. 6, est attaché entre les couvercles.

La chambre à air, entre les Pos. 5 et 7, est raccordée à la soupape de contrôle de la pression. Le produit fini arrive du cylindre de congélation, passe par le tuyau à crème glacée, et continue dans la vanne à crème glacée.

La pression de la chambre à air peut être réglée grâce à la soupape de contrôle de la pression. De cette façon le tuyau en silicone est contracté. Ceci cause une contre-pression dans le cylindre de congélation. La lecture se fait sur le manomètre.

L'orifice de sortie de crème glacée est raccordé au raccord soudé de la vanne, Pos. 7.

L'utilisation de ce système permet une grande variation du foisonnement du produit.

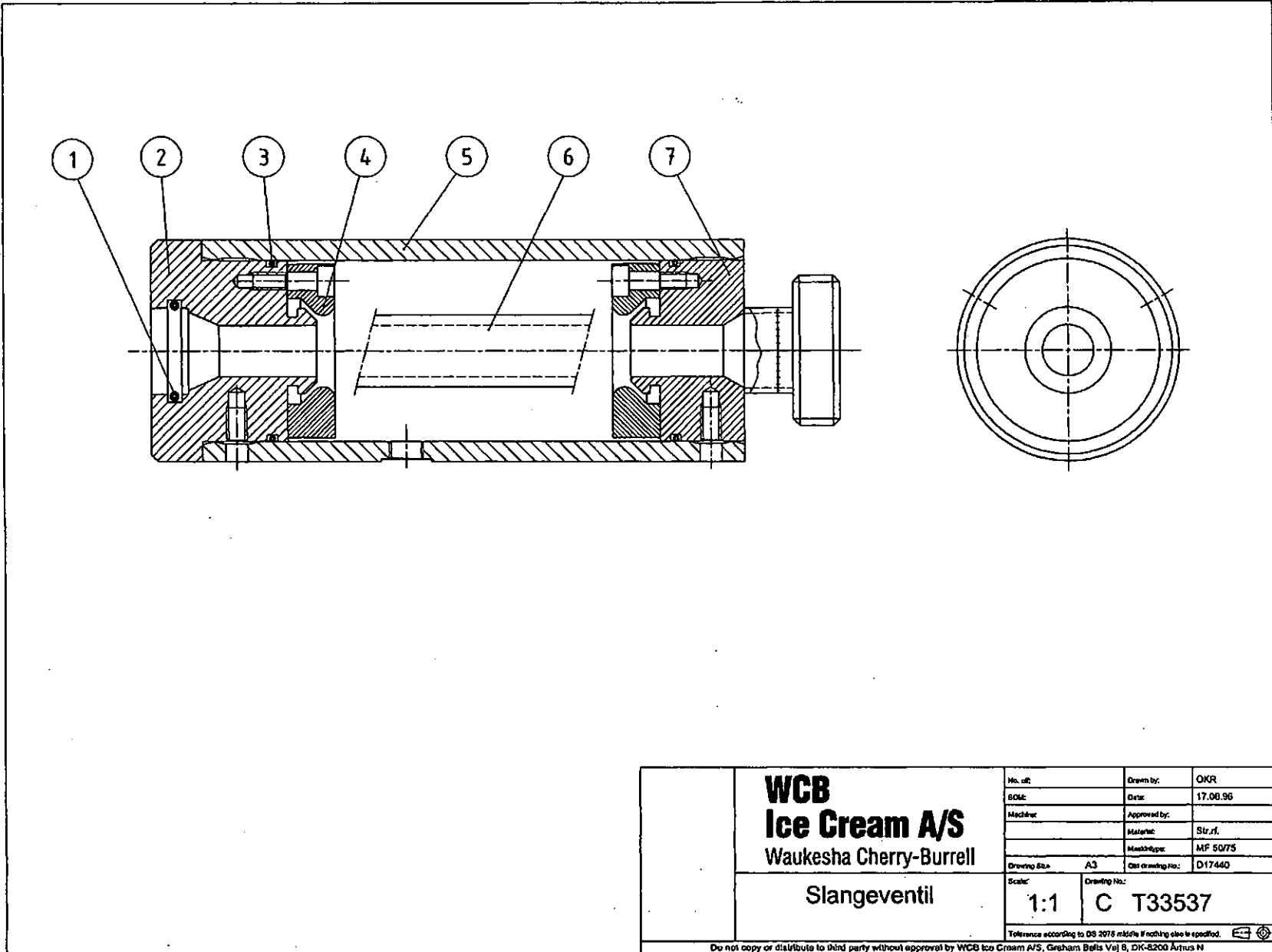

WCB Ice Cream A/S Waukesha Cherry-Burrell Slangeventil	No. of	Drawn by:	OKR
	BOM:	Date:	17.06.96
	Machin:	Approved by:	
		Material:	St.r.f.
		Manufacture:	MF 5075
Drawing Size:	A3	Old drawing No.:	D17440
Scale:	1:1	Drawing No.:	C T33537
Tolerance according to DS 2075 unless otherwise specified.			

Do not copy or distribute to third party without approval by WCB Ice Cream A/S, Graham Belts Vej 9, DK-8200 Århus N

Spare parts lists / Liste de pièces de rechangeT58397

WCB Ice Cream

SPARE PARTS LIST

Date 07/07-06 11:26 Page 1

T58397 Air system - Piston pump/Hose valve

PART NO.	POS.	DESCRIPTION	NUMBER
T1004204	1	Quick-acting coupling	1
T1004205	2	Coupling nipple	1
T1004389	3	Union nut	1
T34089	6	Plate for pneumatic parts	1
T1004202	7	Filter regulator	1
T1004377	8	Fittings for filter regulator	1
T1003973	9	Manometer	1
T1007854	11	Mass flowmeter	1
T1004203	12	Non return valve	1
T1003451	13	Micro filter	1
T1004622	15	Air pressure regulator	1
T1007857	16	Cable for Mass flowmeter	1

T33537

WCB Ice Cream

SPARE PARTS LIST

Date 07/07-06 11:27 Page 1

T33537 Hose valve

PART NO.	POS.	DESCRIPTION	NUMBER
T1004783	1	O-ring	1
T18085	2	End cover	1
T1001803	3	O-ring	2
T9986	4	Clamping ring for hose valve	2
T17437	5	Valve housing	1
T2002624	6	Silicone hose	1
T9984	7	End cover	1



Customer: Masterfoods Steinbourg
Route de Saverne
BP 60203 Saverne Cedex
France

Graham Bells Vej 6
DK-8200 Aarhus N
Denmark
Phone +45 87 41 20 00
Fax +45 87 41 20 01
VAT/CVR No:DK20601043
Bankers: Nordea A/S
Email: wcbice@gowcb.dk
www.wcbicecream.com

Delivery address: Masterfoods Steinbourg
Route de Saverne
BP 60203 Saverne Cedex
France

Our ref.: AWS
Order no: 407193
Date: 07-jul-06

Attention: Mr Alain Picquet

Delivery note

Part no	Description of parts	Quantity delivered
	Document	2

Terms of delivery: DDU

Freight company:

Country of origin: Danmark

Colli 1: Weight: kg, **Dimensions in cm (L x W x H) :**

IMEF

DIRECTION REGIONALE
IMEF LORRAINE
Z.I. Jean Prouvé
39 Rue A. FRUCHARD
54320 MAXEVILLE

DOVEUROPE

Service comptabilité

BP 36

67601 HAGUENEAU Cedex

OFFRE DE PRIX

N° 91120133

Date : 09-07-99

Tél :

Fax :

page 1

A l'attention de Monsieur DEMEIDEIROS

Veillez trouver, ci-après, notre meilleure offre de prix pour :

REPLACEMENT DU SEPARATEUR
D'HUILE SUR LE FREEZER

SEPARATEUR D'HUILE

KIT DE JOINTS CUIVRE

FILTRE DESHYDRATEUR

HUILE FRIGORIFIQUE EMKARATE

FOURNITURES

2 271.00

MAIN D'OEUVRE

3 179.00

↳ rectif d'huile: ?

Espérant avoir répondu à votre attente, nous restons à votre disposition pour tout renseignement complémentaire.

Dans l'attente de vos ordres.
Sincères salutations.

Emetteur : Johann HUPEL

Offre valable 1 mois.

Total hors taxes 5 450.00

T.V.A. 20.90 % soit 1 122.70

TOTAL T.T.C. 6 572.70

TRAVAUX SUR FREEZER

JAEF

numéro	Date	technicien	Nature	forfait	Montant Fr.
①	18/02	Dubois	Recherche de fuites !	3/4	2198
②	24/02	Dubois	Remplacement du compresseur	Devis = 13425 fr.	1288 fr.
				fluide R404A =	
③	05/05	Dubois	Expertise + Relevés	1	2600
④	06/05	Dubois	Remplacement du fluide frigorigène	1	2600
⑤	10/05	Dubois HUPEL	Expertise + Relevés	2 ^{1/4}	5652
⑥	10/06	HUPEL	Dépose de l'échangeur	1 ^{1/2}	3768
⑦	19/06		Changement Séprouba		657170

X
 X
 X
 Non payé
 Non payé
 Non payé
 Non payé

10-0

↳ Faire 1 analyse d'huile: vérifier d'abord de quelle.

TECHNOHOY

DESCRIPTION AND MAINTENANCE

MF 50

IV-07

25

TN

THE REFRIGERATING SYSTEM

DRAWING D 16441

The suction side of the refrigerating compressor 1 is connected to the top of the freezing jacket 2 surrounding the freezing cylinder. The suction line passes through two heat exchangers 5 and 6 and the back pressure regulator 7. The oil separator 8 brings back the oil from the discharge line to the compressor, where it belongs. The sight glass 17 gives a clear visual indication of the function of this system. In this way the jacket 2 is kept practically free of oil, which is of utmost importance to maintain best possible freezing capacity.

The discharge side of the compressor is connected to a condenser 3. In the condenser the condensing heat is transferred to the cooling water, the amount of which is controlled by the automatic water regulating valve 15. From the condenser the now liquified Freon flows through the liquid line with a filter 14, through both of the heat exchangers 6 and 5, in counter flow to the Freon gas in the suction line, through the solenoid valve 4, a sight glass 10, to the thermostatic valve 11, the bulb of which is clamped to the suction line between the two heat exchangers. The suction line between 2 and 5 will carry a mixture of Freon gas and liquid. In the liquid will be dissolved some oil, originating from the compressor, from which it has been carried to the evaporator through condenser and liquid line.

TECHNOHOY

DESCRIPTION AND MAINTENANCE

MF 50

IV-08

26

TN

In the heat exchanger 5 the liquid part of the Freon is evaporated by means of heat from the counterflowing warm liquid.

The purpose of the second heat exchanger 6 is to afterevaporate traces of liquid Freon after the first heat exchanger.

The purpose of the automatic but adjustable valve 7 is to keep a constant pressure, and thereby also a constant temperature in the jacket 2. This pressure which is shown by the square pressure gauge 16, must by necessity, be higher than the pressure in the suction port of the compressor, which is shown by the pressure gauge LP. The pressure difference is created by the throlling action of the valve 7. When the freezer is working at low capacity the valve 7 is adjusted to keep a relatively high pressure in the jacket 2, while at the same time the compressor is able to pull the pressure after the valve 7 down to a relatively low value. The pressure difference between 16 and LP is then large. If now the refrigerating load is increased by increasing the throughput and the stiffnes of the product, the back pressure regulating valve 7 must be adjusted to keep a lower pressure and temperature in the jacket 2. The throttling action is reduced and the pressure at LP rises. The pressure difference between 16 and LP is then low.

TECHNOHOY

DESCRIPTION AND MAINTENANCE

MF 50

IV-09

27

TN

By further increasing and refrigerating load, the pressure difference reaches a minimum. The valve 7 is then wide open, and the limit of the compressor capacity has been reached. It is evident, that the mentioned pressure difference is a good measure for the load of the refrigerating system.

HP is a pressure gauge showing the condensing pressure and temperature. In principle this pressure should be kept as low as possible to obtain highest possible refrigerating capacity, lowest possible consumption of electricity and lowest possible discharge temperature of the compressor. This advantage must be paid for by a high consumption of cooling water however. 15 is an automatic water regulating valve, placed in the water inlet to the condenser. It has a pressure sensitive element which is connected to the discharge port of the compressor. The element has the function to open the valve, when pressure is build up, and let so much water flow through the condenser as necessary to keep the condensing pressure at the value which is preset by the adjustment knob of the water valve. When making adjustments of the water flow, the effect should be followed on the gauge HP. From the factory the valve is set to keep the condensing temperature at about 30° C. It depends very much on local conditions however, to which condensing temperature the water valve should be set. If water is plentiful, cheap and perhaps warm, much water should be used and vice versa.

TECHNOHOY

DESCRIPTION AND MAINTENANCE

MF 50

IV-10

28

50

THE FREEZING CYLINDER ASSEMBLY AND MAIN DRIVE DRAWING U 5437

The freezing tube 7, made of stainless steel and hard chromium plated on the interior surface, is surrounded by the eccentrically placed jacket 8 with heads 8a and 8b. The annular space so formed is the evaporator for Freon, which cools the freezing tube.

Tightness between the heads and the freezing tube is obtained by O-rings 5 and 28. End covers 1 and 6 are attached to the ends of the freezing tube by bayonet style locks. 31 is the inlet connection for ice cream mix with air, and 19 is the outlet connection for the finished product. Centrally placed in the cylinder is the solid mutator 20 suspended between the anchor plate 21 and the driving stud 14. The torque from the main shaft is transmitted to the mutator shaft 27 through the driving stud 14. The right end of the mutator, the shaft 27 is sealed against the cover 6 by means of the rotary shaft seal 9 and engaged with the main shaft 39. The V-belt pulley 42, is secured to the main shaft by the taper lock bushing 43. The main shaft is suspended in two ball bearings 11 and 15. The first mentioned, being the heavier, is designed to take the axial thrust from the internal pressure in the freezing tube.

TECHNOHOY

DESCRIPTION AND MAINTENANCE

MF 50

IV-11

29

50

MAINTENANCE U 5437

The freezing tube 7 is removable. If the tube needs to be replaced, or for other reasons taken out of the freezer, the low side of the refrigerating system must be pumped down. This should be done by a competent refrigerating service engineer, NEVER by an unexperienced person. Remove both of the covers 1 and 6 and the mutator assembly, by hand. Remove the union nut 4 with a tool delivered with the freezer. The freezing tube can then be pulled out. When reinstalling the tube make sure, that everything is clean, and that the O-rings are of proper quality for use in connection with Freon, and that they are properly oiled with refrigerating compressor oil and that the dowel pin 3 is exactly opposite its slot. Loosen the expansion ring 29, if necessary. Then drive home the tube with a wooden block and a bench hammer. Tighten the union nut 4 firmly. Tighten the screws evenly but not too firmly. Check for leaks with a halide leak detector, electric type.

If, after considerable use, the shaft seal 9 gets leaky inspect the running surfaces of the seal rings. Also inspect the two O-rings. It is important, that the spring is able to push the rotating seal ring on the shaft, if compressed. The shaft should therefor be lubricated occasionally with an edible lubricant. If any part of the shaft seal gets scored, the entire shaft seal must be replaced with a new one.

TECHNOHOY

DESCRIPTION AND MAINTENANCE

MF 50

IV-12

30

50

Power from the main motor is transmitted to the main shaft through a V-belt. If it ever becomes necessary to replace the V-belt, proceed as follows : Remove the V-belt from its groove. Remove the screws holding 40 and 41. Remove the ball bearing house 41. The old belt can now be slipped over the end of the shaft and out, and the new belt can be inserted the same way.

If it, for some reason, is necessary to remove the main shaft 39 and the nose 32, which is fastened to the shaft with right hand thread. Loosen the taper lock in the main V-belt pulley. Remove the ball bearing 15. The cover 40 and the taper lock can now be taken out, and the shaft can be moved to the right. Now lift the left end of the shaft up and take the shaft out of the machine. It is now possible to renew the ball bearing 11 and the seal rings 33, 34, 35 and 36.

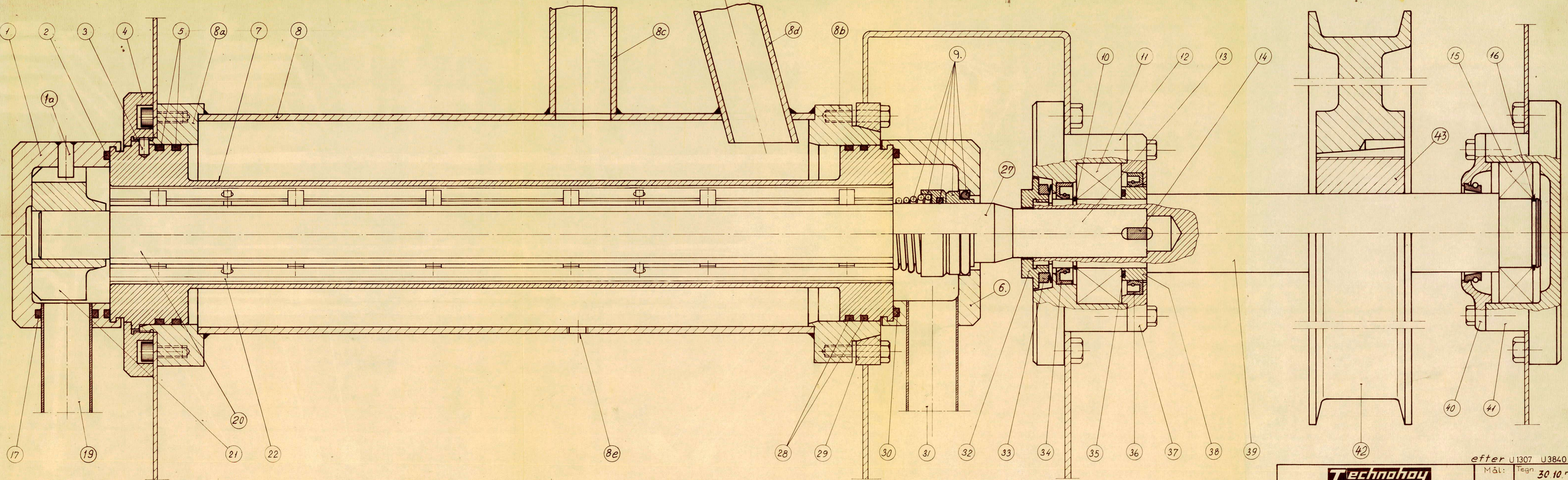

efter U 1307 U 3840

Technohoy
 CIVILINGENIØR OG HØYER
 AARHUS - DANMARK

Mål: Tegn 30.10.79
 1:1 Maskine type MF 50

Frysecylinder med hovedtræk

erstatte U 1307
 U 5437

TECHNOHOY

DESCRIPTION AND MAINTENANCE

MF 50

IV-13

31

A

SPEED ADJUSTING OF THE PUMPS C 2954

The dial 19, with figures from 0 to 10, is driven from the spindel 6 through gear trains 20, 21 and 23. The sprocket 7 is connected to the STRÖTER gear head motor through a 3/8" roller chain, running over the take up pulley 18.

The dial 19 makes one turn when the pump capacity is adjusted from max. to min.

The figures 0 to 10 are reference figures only.

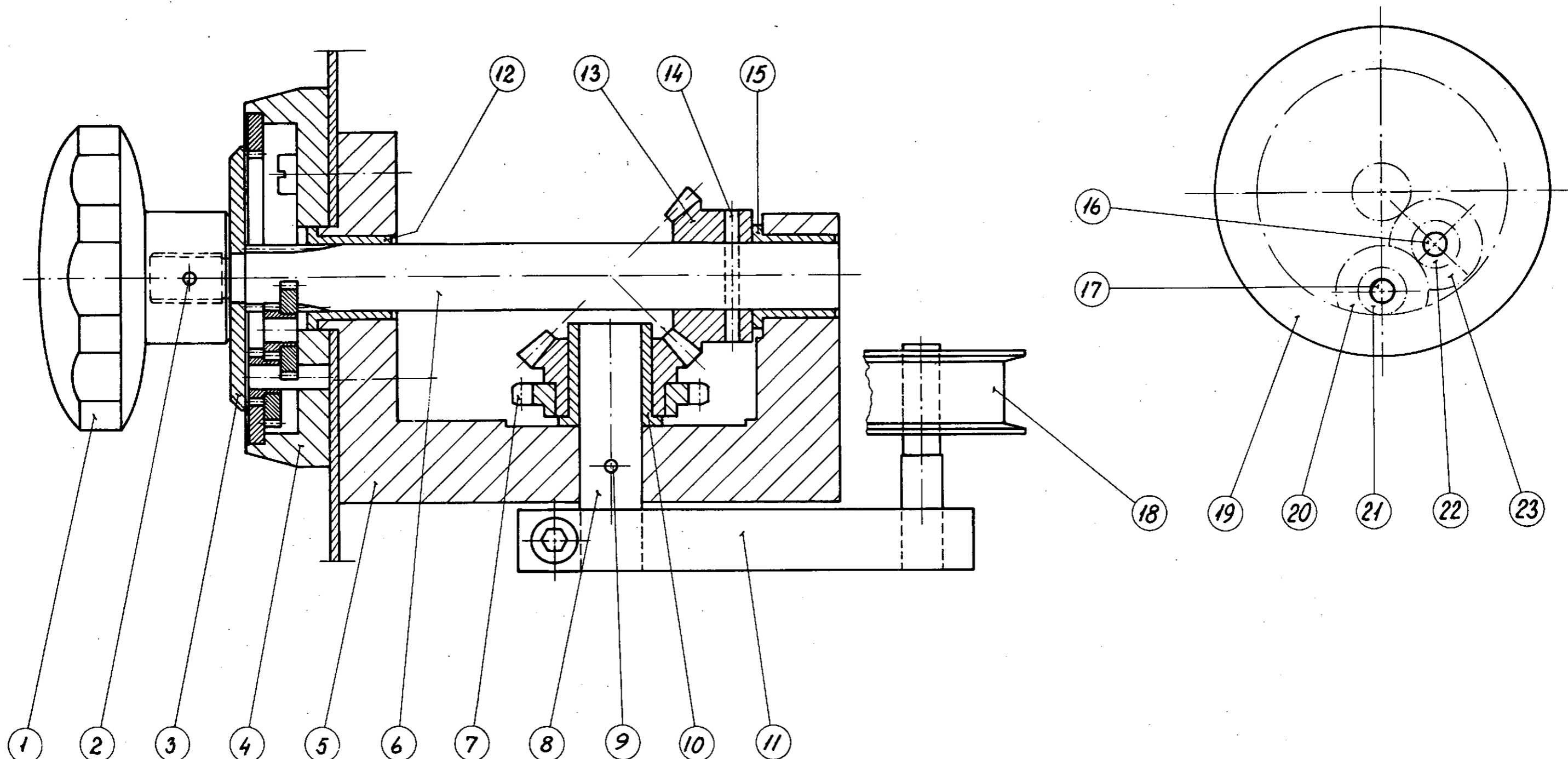

Stk.	Genstand	Mrk. nr.	Tegn. nr.	Materiale	Model nr. Lager nr.	Vægt
	Dato	Rettelse	Dato	Rettelse		
TECHNOLOY CIVILINGENIØR O. Ø. HØYER AARHUS - DANMARK				Målforhold	Tegn.	30.1.78
				1:1	Kont.	R
					Normpr.	
Hast. regulering af pumper.				(Erstatning for:)		
				C 2954		
				(Erstattet af:)		



PRESTCOLD



BY APPOINTMENT TO HER MAJESTY THE QUEEN
MANUFACTURERS OF REFRIGERATION MACHINERY
PRESTCOLD LIMITED THEALE, BERKS

L

Semi-hermetic Compressors
Compresseurs Semi-hermétiques
Halbhermetische Kompressoren

50Hz

2 - 4
hp/ch/PS

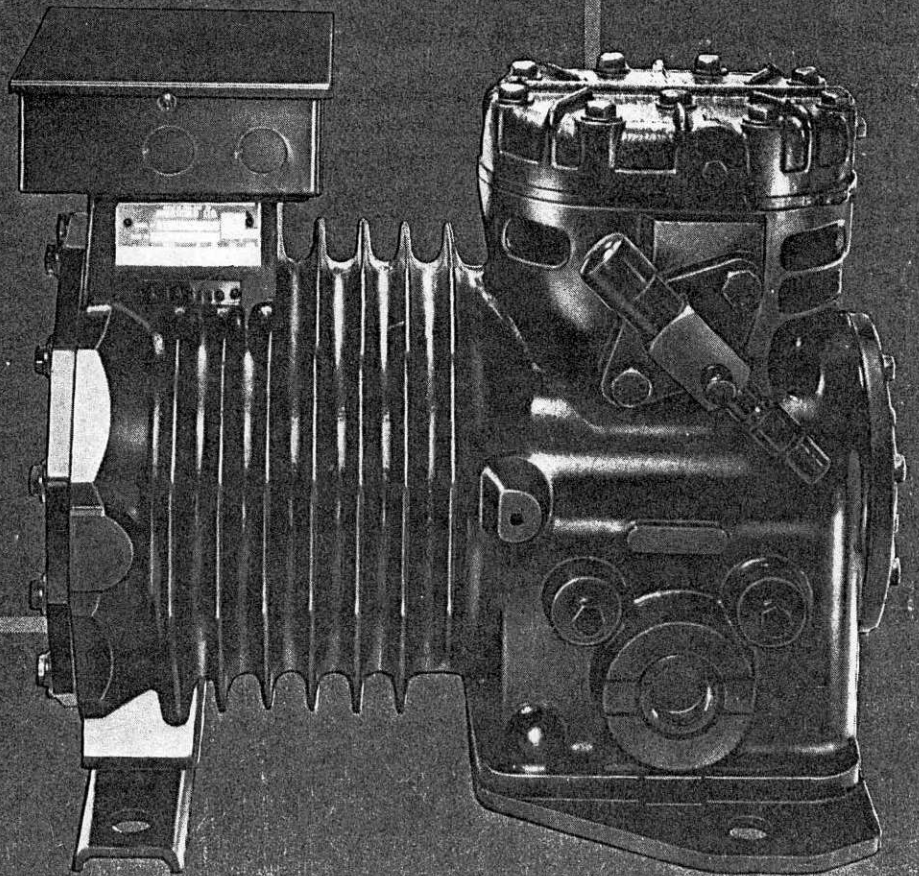

Firma:

TECHNOLOGY
 CIVILINGENIØR OG HØYER
 AARHUS · DANMARK

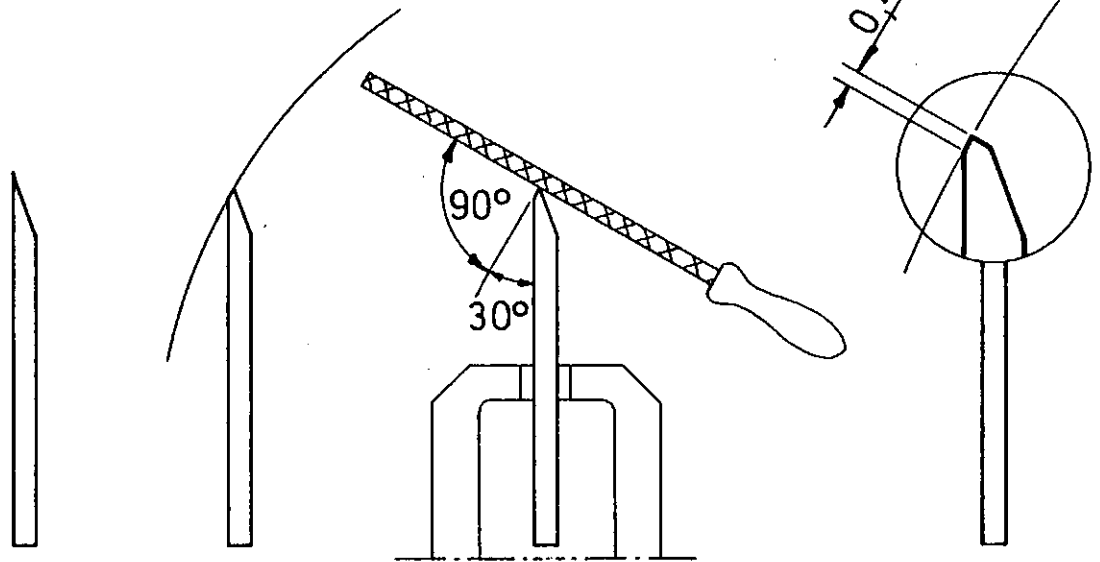
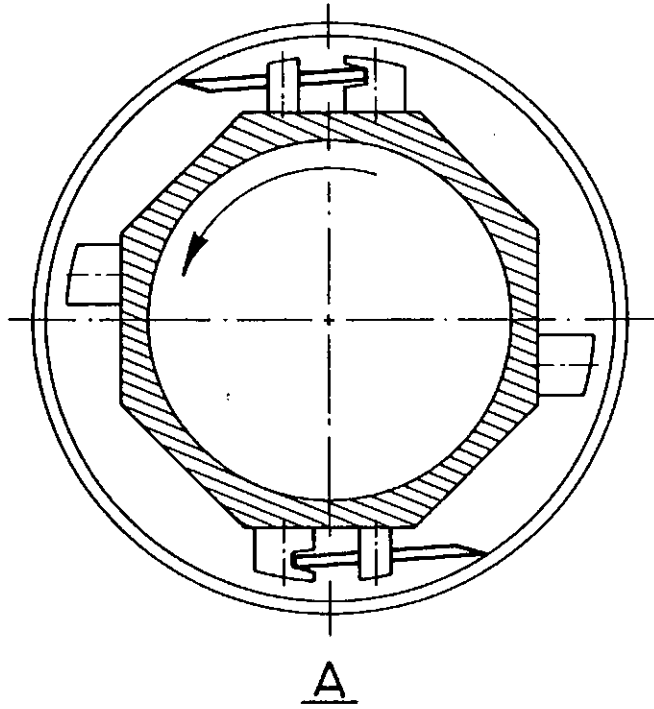

NEW WORN-IN RECONDITIONING READY FOR
USE

mm

Alle mål uden tolerance ±

<i>erst. af D4058</i>	Materiale	Model nr.	Lager nr.	Målforshold	Tegn.	78.06.08.
					Kont.	TR
Genstand: RECONDITIONING WORN SCRAPER BLADES					Tg. nr.	D 3140

TECHNOHOY

DESCRIPTION AND MAINTENANCE

MF 50

IV-14

32

A

RECONDITIONING OF WORN SCRAPER BLADES

Drawing D 3140 shows, at A, a section through the freezing cylinder, with mutator and scraper blades. The mutator turns anti-clockwise, when seen from the front of the freezer. The leading edge of the blades must be in contact with the refrigerated cylinder wall, by centrifugal force, and when in proper condition, they scrape off the thin layer of ice cream which freezes on to the cylinder wall between passages of the scrapers. It is evident, that the blades must be kept in good condition in order to scrape off efficiently, which is of so deciding importance for the performance of the freezer.

At 1 is shown a new and unused blade. It has a rather sharp cutting edge. 2 shows the blade after some use. The blade is "worn-in" against the cylinder surface. A narrow contact area has developed over the entire length of the blade. After considerable use this contact face gets so wide, say 1,5 mm, that reconditioning becomes necessary, in order to maintain scraping efficiency. At 3 is shown how to proceed. Put the blade in a vise and use a saw mill file to remove material from the edge as shown. The file should be held at approximately 90° to the contact face. Continue filing till the width of the face has been reduced to between 0.4 and 0.6 mm. Such a small portion should be left over to insure good contact between blade and cylinder wall. NEVER remove the face completely.

TECHNOHOY

DESCRIPTION AND MAINTENANCE

MF 50

IV-15

33

A

THE ELECTRICAL INSTALLATION

The drawing is made in accordance with international standard and practise.

The wirings for the pump motor and the main driving motor are straight forward.

The compressor motor is equipped with a local protection system against overload and burn out. Thermistor temperature sensors are placed in the motor windings.

SEE WIRING DIAGRAM

If the allowed temperature of the windings is exeeded, the electrical resistance in the sensors rises abruptly, which causes a relay in the control box to break the connection, where by the compressor motor is stopped through the motor contactor. A new start can normally be made after 5-6 minutes.

The heating element, if any, is located in the crank case of the compressor, immersed in the oil. Electrically it is connected in such a way, that it is on, when the motor is off and vice versa. This is done to avoid absorption of Freon in the oil during stand still periods of the compressor. Even during long periods of standstill, there is no danger of superheating of the oil because of the small heating capacity. A consequence of the above is, that the main switch on the wall should NEVER be pulled and that the freezer should be switched on app. 3-8 hours before production.

MAIN SWITCH / CIRCUIT INTERRUPTER

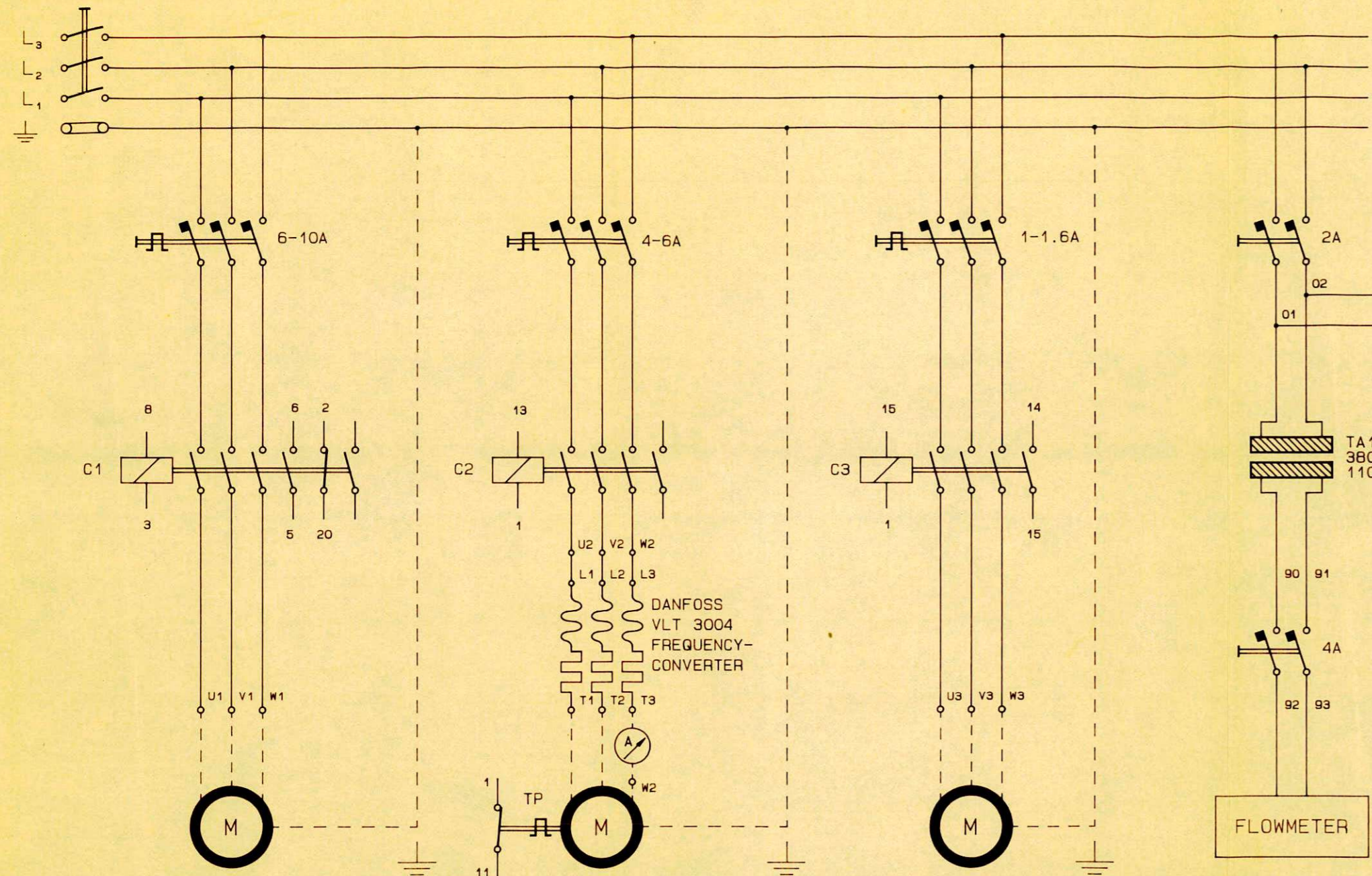

COMPRESSOR

MAIN MOTOR

PUMP MOTOR

TERMINAL STRIP IN MAIN CURRENT CABINET

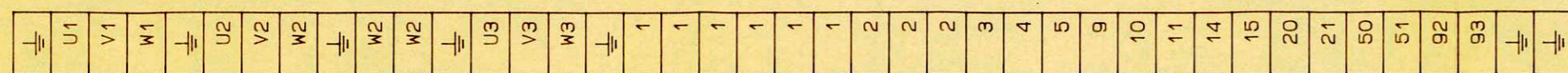

VLT FREQUENCY CONVERTER
CONTROLLING STRIPS FOR
SPEED REGULATION

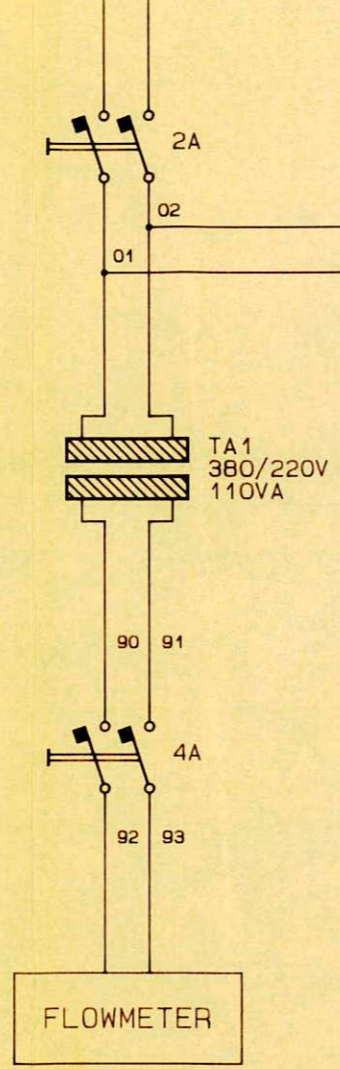

FLOWMETER

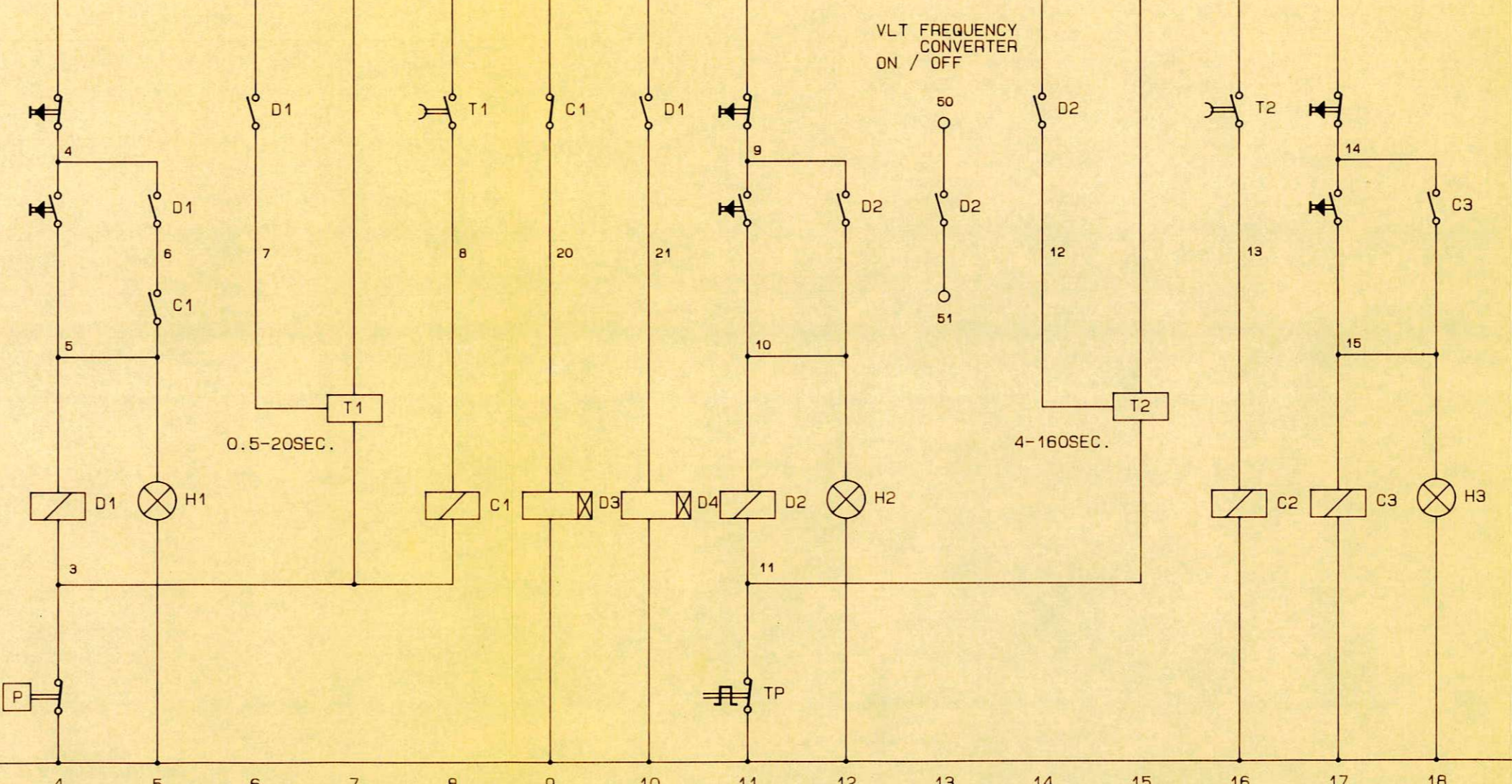

TERMINAL STRIP IN CABINET FOR FLOWMETER

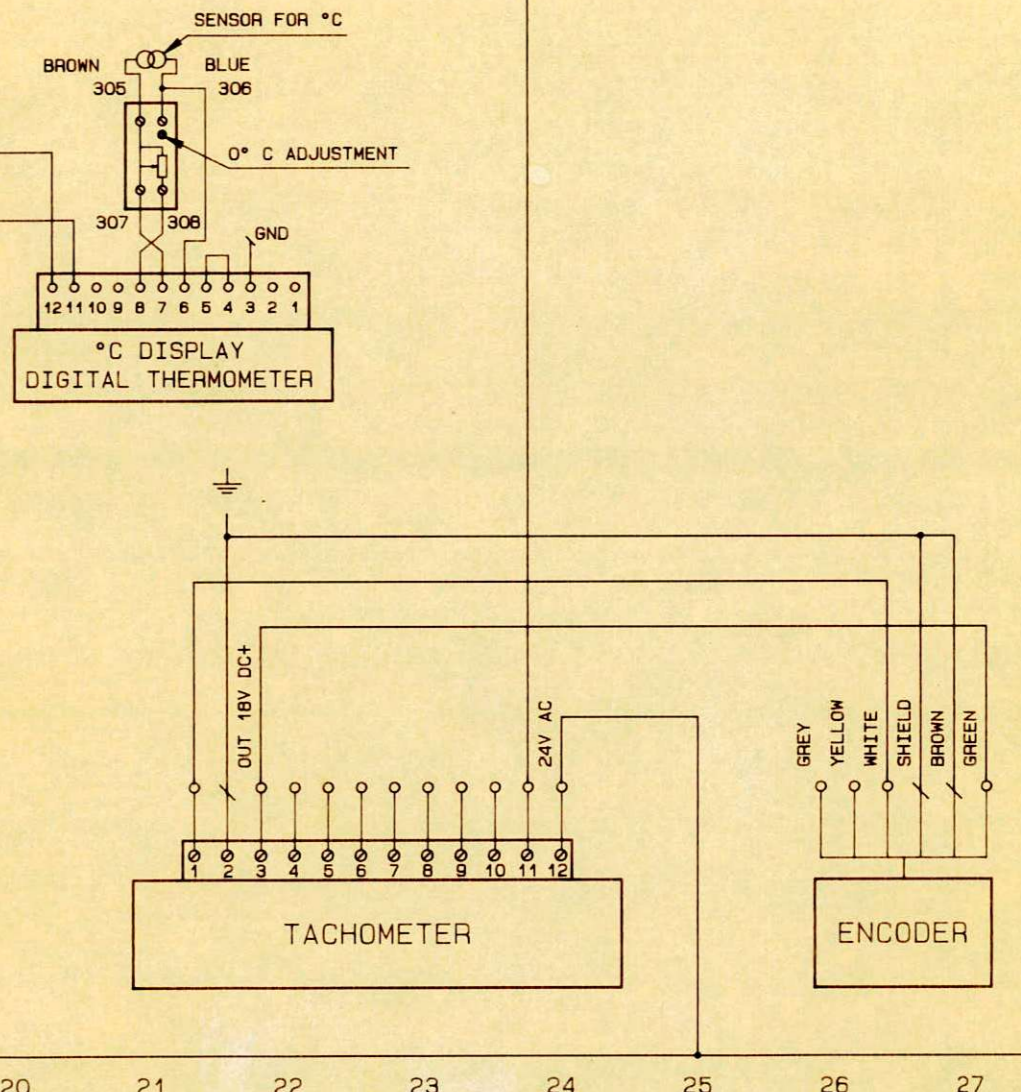
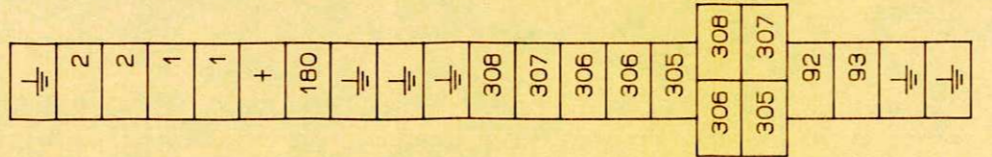

TECHNOHOY		DATE: 26.09.90.
CARL HOYER A/S		SIGNATURE: DSM
AARHUS-DENMARK		U
Wiring diagram		
VOLTAGE: 3X380V ± .50c/s, min.20A fuse		U 16199
MACHINE TYPE: MF 50, no.67, DOVEUROPE S.A., F		

GENERAL SPECIFICATION

Type: Semi-hermetic, twin cylinder, externally cooled, reciprocating compressor.

Operating Speed: 1450 rpm (except L200/0028 — 960 rpm)

Application: R12, 22, 502 and 13B1.

DESIGN FEATURES

Crankshaft: cast iron, with oilways lubricating all bearing surfaces.

Pistons: High grade cast iron pistons, oil grooved and precision finished. Case-hardened steel gudgeon pins fitted with brass end pads to protect the cylinder walls.

Connecting Rods: light alloy.

Lubrication: Splash lubrication is used on all models except the L400/0062 which is fitted with a reversible oil pump.

Oil Charge: 2.3 litres.

Sight Glass: Standard on all compressors.

MODEL DESIGNATION

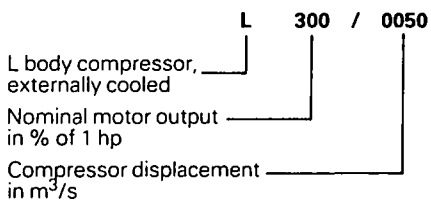

The new range of compressors incorporates a change of model designation. The designations in brackets on the individual performance curves indicate the nearest equivalent 'S' compressor model.

CARACTERISTIQUES GENERALES

Type: Compresseur alternatif à deux cylindres de type semi-hermétique à refroidissement externe.

Vitesse de fonctionnement: 1450 tr/min (sauf L200/0028 — 960 tr/min).

Utilisation: R12, 22, 502 et 13B1.

SPECIFICATIONS TECHNIQUES

Vilebrequin: en fonte avec canalisations d'huile pour lubrification des pièces mobiles.

Pistons: en fonte de haute qualité à rainures d'huile et parachevés avec soin. Les axes de piston d'acier cémenté sont munis en bout de pièces de laiton pour protéger les parois du cylindre.

Bielles: en alliage léger.

Lubrification: Tous les compresseurs ont un système de graissage par barbotage, à l'exception du L400/0062 qui est muni d'une pompe à huile réversible.

Charge d'huile: 2.3 litres.

Voyant de niveau d'huile: Standard.

DESIGNATION

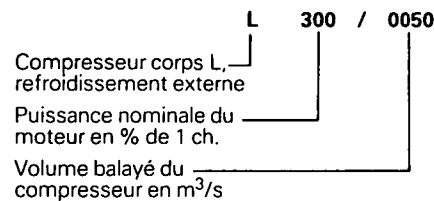

Un nouveau système de désignation des compresseurs de la nouvelle série L a été introduit. Les modèles indiqués entre parenthèses sur les courbes de puissances individuelles sont des équivalents approximatifs de l'ancienne série 'S'.

AUSFÜHRUNG

Typ: fremdgekühlter, halbhermetischer Zweizylinderkolbenkompressor.

Drehzahlen: 1450 U/min (ausser dem L200/0028 — 960 U/min).

Anwendung: R12, 22, 502 und 13B1.

KONSTRUKTIONSMERKMALE

Kurbelwelle: aus hochwertigem Gußeisen, mit Ölkämen.

Kolben: aus hochwertigem Gußeisen, mit Schmiernuten versehen und fein bearbeitet. Die Kolbenbolzen aus schalenhartem Stahl haben zum Schutz der Zylinderwände Endpolster aus Messing.

Pleuelstangen: aus Leichtlegierung.

Schmierung: Alle Kompressoren ausser dem L400/0062, der mit einer drehrichtungsunabhängigen Ölpumpe ausgerüstet ist, haben Schleuderschmierung.

Ölfüllung: 2.3 liter.

Schauglas: Standardmäßig.

MODELLBEZEICHNUNG

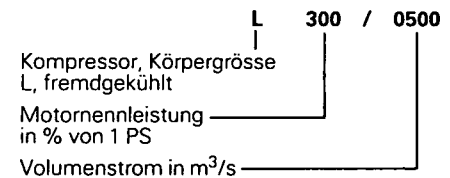

Die neue Typenreihe L beinhaltet eine neue Modellbezeichnung. Die auf den einzelnen Leistungskurven in Klammern aufgezeichneten Typen beschreiben die gleichwertigen Typen der 'S'-Serie.

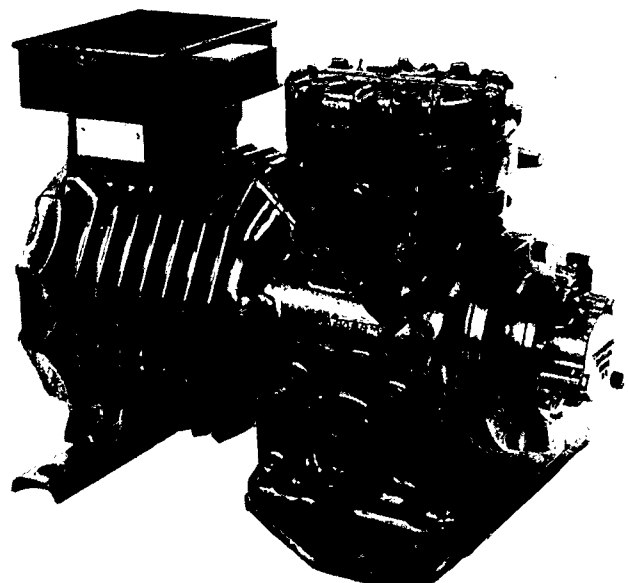

L400/0062

Technical Data Caractéristiques Techniques Technische Daten

Model / Modèle / Modell		L200/0028	L200/0037	L300/0037	L200/0042
Displacement at 960 rpm Volume balayé à 960 tr/min Volumenstrom bei 960 U/min	m ³ /s m ³ /h	0.0028 10.0			
Displacement at 1450 rpm Volume balayé à 1450 tr/min Volumenstrom bei 1450 U/min	m ³ /s m ³ /h		0.0037 13.3	0.0037 13.3	0.0042 15.0
Nominal motor power Puissance nominale du moteur Motornennleistung	kW	1.5	1.5	2.2	1.5
Refrigerant and application range Réfrigérant et plage d'application Kältemittel und Anwendungsbereich	R12 R22 R502 R13B1	ML ML	HML L L XL	HML L	ML L
No. of cylinders No. de cylindres Zylinderanzahl		2	2	2	2
Bore Alésage Bohrung	mm	50.8	47.5	47.5	50.8
Stroke Course Hub	mm	43	43	43	43
Suction valve Vanne d'aspiration Sauganschluss	O.D. ∅ ∅	7/8" (22 mm) SW	7/8" (22 mm) SW	7/8" (22 mm) SW	7/8" (22 mm) SW
Discharge valve Vanne de refoulement Druckanschluss	O.D. ∅ ∅	5/8" (15 mm) FL	5/8" (15 mm) FL	5/8" (15 mm) FL	5/8" (15 mm) FL
Oil charge Charge d'huile Ölfüllmenge	Litres	2.3	2.3	2.3	2.3
Net weight Poids net Nettogewicht	kg	82	82	86	82

NOTES

Connections:

SW = Sweat connection
FL = Flare connection

Application range

H = t₀ = -10°C to +15°C
M = t₀ = -20°C to 0°C
L = t₀ = -40°C to -10°C
XL = t₀ = -60°C to -35°C

NOTA

Raccords:

SW = Raccord à braser
FL = Raccord évasé

DIMENSIONS DIMENSIONS ABMESSUNGEN

Model / Modèle / Modell	Suction Side Côté Aspiration Saugseite		Discharge Side Côté Refoulement Druckseite	
	A	B	A	B
L200/0028 L200/0037 L300/0037 L200/0042 L300/0042 L300/0050 L400/0050	156 mm	276 mm	175 mm	259 mm
L300/0062 L401/0062 L400/0062	150 mm	270 mm		

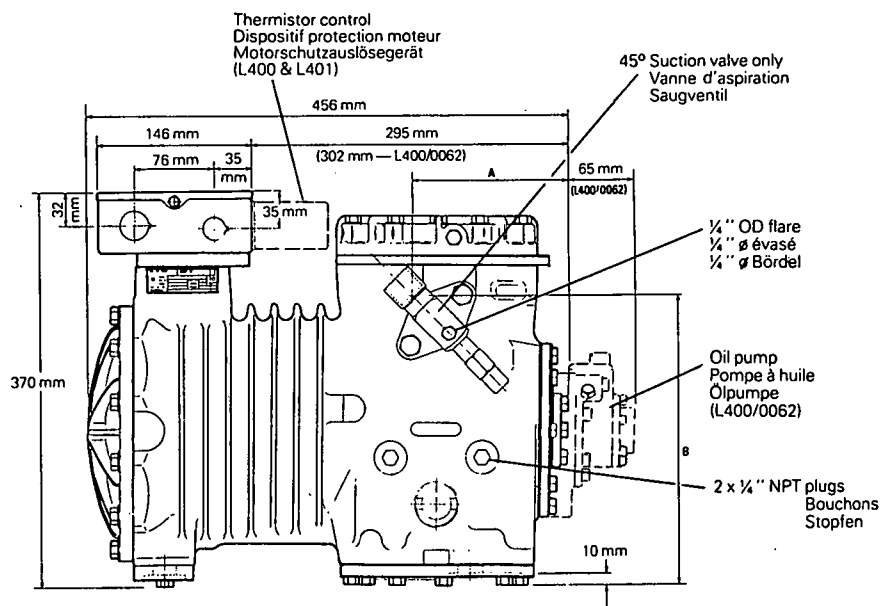

L300/0042	L200/0050	L300/0050	L400/0050	L300/0062	L401/0062	L400/0062
0.0042 15.0	0.0050 18.1	0.0050 18.1	0.0050 18.1	0.0062 22.4	0.0062 22.4	0.0062 22.4
2.2	1.5	2.2	3.0	2.2	3.0	3.0
HML ML L	L	HML L L XL	ML L	HML L	HML L XL	HML L XL
2	2	2	2	2	2	2
50.8	55.6	55.6	55.6	62	62	62
43	43	43	43	43	43	43
7/8" (22 mm) SW	7/8" (22 mm) SW	7/8" (22 mm) SW	7/8" (22 mm) SW	1 1/8" (28 mm) SW	1 1/8" (28 mm) SW	1 1/8" (28 mm) SW
5/8" (15 mm) FL	5/8" (15 mm) FL	5/8" (15 mm) FL	5/8" (15 mm) FL	5/8" (15 mm) FL	5/8" (15 mm) FL	5/8" (15 mm) FL
2.3	2.3	2.3	2.3	2.3	2.3	2.3
86	82	86	89	86	89	91

Plage d'application

H = $t_0 = -10^{\circ}\text{C}$ à $+15^{\circ}\text{C}$
M = $t_0 = -20^{\circ}\text{C}$ à 0°C
L = $t_0 = -40^{\circ}\text{C}$ à -10°C
XL = $t_0 = -60^{\circ}\text{C}$ à -35°C

ANMERKUNGEN

Anschlüsse:
SW = Lötanschluss
FL = Bördelanschluss

Anwendungsbereiche

H = $t_0 = -10^{\circ}\text{C}$ bis $+15^{\circ}\text{C}$
M = $t_0 = -20^{\circ}\text{C}$ bis 0°C
L = $t_0 = -40^{\circ}\text{C}$ bis -10°C
XL = $t_0 = -60^{\circ}\text{C}$ bis -35°C

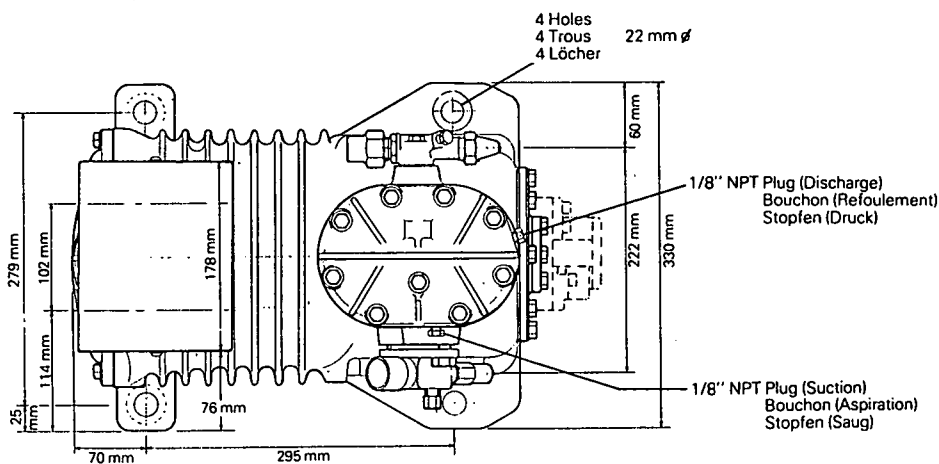

Flexible mountings: Set no. 97120/0163 (optional) overall height increased by 28 mm.

Fixations souples: Jeu référence 97120/0163 (sur option) ajouter 28 mm à la hauteur totale.

Montagefedern: Satz 97120/0163 (wahlweise) vergrößern die Höhe um 28 mm.

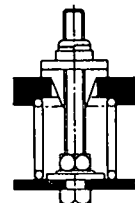

L APPLICATION NOTES CONSEILS D'UTILISATION ANWENDUNGSHINWEISE

Design – Compressors are suitable for use with refrigerants 12, 22, 502 and 13B1 within the limits indicated on the individual data sheets to cover a wide variety of applications in the 2 to 4 nominal horsepower range.

Performance curves – These are based on the following conditions:

- Liquid at saturation temperature corresponding to the discharge pressure with no sub-cooling. For each 1°C of liquid sub-cooling at the condenser outlet, 1% may be added to the extraction rate.
- The suction gas entering the compressor being usefully heated to the maximum permitted temperature stated on the performance data.
- A compressor speed of 960 rpm for model L200/0028 and 1450 rpm for all other models.
- A maximum ambient temperature of 43°C.

Due to variations resulting from manufacturing tolerances, actual performance may differ from published figures by up to 5%.

It should be noted that the effective extraction rating of a given installation may be much lower than the compressor performance due to system losses caused by pressure drops, non-useful heat pick-up in the suction line, expansion valve losses, etc. This is particularly so on low temperature applications.

To minimise system losses, the following factors must be given careful consideration in the design of each installation:

- Sizing of pipework and evaporator to give minimum pressure drop whilst maintaining a velocity high enough to ensure good oil return.
- The use of insulation on the suction line to prevent heat pick-up from its surroundings.
- Whether a suction to liquid line heat exchanger of suitable size should be used.
- Selection of the correct size and type of expansion valve.
- Whether compressor cooling is adequate, especially at low suction pressure.

Operational limits – In all cases the compressor motor is matched to the displacement, the refrigerant and the range of application and care must be taken to ensure that compressors operating on low suction pressures are not allowed to operate continuously at suction pressures exceeding the permitted limits. The performance data provides heat extraction figures within prescribed operating parameters and the compressors should not be applied outside these limits if motor overloading is to be avoided.

A short interval of operation above the limiting suction pressure, during a quick pull down, can be tolerated but when the evaporating pressure is liable, for any reason, to exceed these limits for any length of time, means of restricting the suction pressure must be applied. A pressure limiting expansion valve is most suitable, or alternatively, some form of throttling device must be used in the suction line.

Gas temperature – To avoid excessive

Construction – Les compresseurs type 'L' s'utilisent avec les réfrigérants 12, 22, 502 ou 13B1 dans les limites spécifiées dans leurs fiches techniques individuelles et conviennent de ce fait à une grande variété d'usages dans une gamme de puissance nominale de 2 à 4 ch.

Courbes de puissance – Les courbes de puissance s'entendent pour les conditions suivantes:

- Liquide à la température de saturation qui correspond à la pression de refoulement sans sous-refroidissement. Pour chaque °C de sous-refroidissement de liquide à la sortie du condenseur, ajouter 1% à la puissance indiquée.
- Les gaz aspirés à l'entrée du compresseur avec surchauffe utile jusqu'à la température maximum permise comme indiquée sur les courbes de puissance.
- Vitesse de rotation 1450 tr/min, sauf le modèle L200/0028 – 960 tr/min;
- Une température ambiante maximale de 43°C;

En raison des tolérances de fabrication, les puissances indiquées peuvent varier de ±5%.

Noter que la puissance "réelle" d'une installation peut être nettement inférieure à la puissance du compresseur en raison de pertes de puissance occasionnées par chutes de pression, apport de chaleur non-utile dans la conduite d'aspiration etc, surtout pour les installations à basse température.

Afin de réduire ces pertes au minimum, il faut tenir compte des points suivants:

- Etudier la tuyauterie et l'évaporateur de façon à assurer une chute de pression minimum ainsi qu'une vitesse d'écoulement suffisante à assurer un bon retour d'huile;
- Déterminer si la conduite d'aspiration devrait être isolée sur toute sa longueur afin d'éviter un apport de chaleur de l'ambiance.
- Considérer l'utilisation d'un échangeur de chaleur "aspiration/refoulement".
- Choisir avec soin un détendeur qui convient au système.
- Assurer le refroidissement efficace du compresseur, surtout aux pressions d'aspirations basses.

Limites d'application – Dans tous les cas, le choix du moteur du compresseur est fait en fonction de son volume balayé, le frigorigène utilisé et sa plage d'application. Il importe d'éviter l'utilisation continue des compresseurs aux températures de gaz aspirés supérieures aux conditions limites indiquées. Les courbes de puissance frigorifique des compresseurs donnent leur capacité en dedans de leur plage d'application, les limites de laquelle doivent être respectées afin d'éviter le surcharge éventuel du moteur.

Une brève période d'utilisation du compresseur en dessus de la limite indiquée de pression des gaz aspirés pendant la mise en régime est permise, mais lorsque la pression des gaz aspirés est susceptible de dépasser cette limite pendant un certain temps, il faut que la pression des gaz aspirés soit limitée. Ceci peut se faire à moyen d'un détendeur limiteur de pression 'MOP' ou autre dispositif d'étranglement monté sur la

Anwendung – Die Kompressoren eignen sich zum Gebrauch mit den Kältemitteln R12, R22, R502 und R13B1 innerhalb der auf den individuellen Datenblättern angegebenen Grenzen für eine Vielfalt von Anwendungen im Nennleistungsbereich von 2 bis 4 PS.

Leistungskurven – Diese basieren auf den folgenden Annahmen:

- Flüssigkeit auf Sättigungstemperatur entsprechend dem Austrittsdruck ohne Unterkühlung. Für je 1°C Unterkühlung der Flüssigkeit am Verflüssigerausstritt kann 1% zur Kälteleistung zugeschlagen werden.
- Das in den Kompressor eintretende Sauggas durch Wärmeaustauscher auf die in den Leistungsdaten angegebene höchstzulässige Temperatur vorgewärmt.
- Kompressor-Drehzahl 1450 U/min für alle Modelle, ausser dem L200/0028 – 960 U/min.
- Maximale Umgebungstemperatur 43°C.

Die Leistungsdaten können durch Fertigungstoleranzen um 5% abweichen.

Es ist zu beachten, daß die effektive Leistung einer speziellen Anlage erheblich geringer sein kann als die Kompressorleistung, entsprechend der Verluste, die durch Erwärmung der Saugleitung, Druckverluste, Expansionsventile und sonst Drosselorgane entstehen. Dies gilt besonders für den Tieftemperaturbereich. Um diese Verluste so gering wie möglich zu halten, sind bei Festlegung einer Installation folgende Punkte zu beachten:

- Rohrleitung und Verdampfer müssen so dimensioniert sein, daß ein möglichst geringer Druckabfall einerseits, jedoch eine ausreichende Geschwindigkeit andererseits möglich ist, um eine gute Ölrückführung zu erreichen.
- Eine Isolierung der Saugleitung auf ihrer Gesamtlänge verhindert die Wärmeaufnahme aus der Umgebung.
- Es ist zu entscheiden, ob ein passender Wärmeaustauscher eingesetzt wird.
- Die richtige Expansionsventil-Größe und-Type ist sorgfältig auszuwählen.
- Sicherstellen, daß ausreichend Kühlung für den Kompressor vorhanden ist, speziell für den Tieftemperaturbereich.

Anwendungsgrenzen – In allen Fällen ist der Kompressormotor an das Hubvolumen, das Kältemittel und den Anwendungsbereich angepaßt, und es ist sorgfältig darauf zu achten, daß mit niedrigen Ansaugdrücken arbeitende Kompressoren nicht ununterbrochen bei Ansaugdrücken betrieben werden, die die zulässigen Grenzen überschreiten. Die Leistungsdaten lassen Kälteleistungen in den Grenzen vorgeschriebener Betriebsparameter zu, und die Kompressoren dürfen nicht außerhalb dieser Grenzen betrieben werden, um Motorüberlastung zu vermeiden.

Kurzzeitiger Betrieb oberhalb des Grenz-Ansaugdrucks während eines schnellen Abkühlvorgangs ist zulässig; wenn aber der Verdampfungsdruck aus irgendeinem Grunde für längere Zeit die Grenzen überschreiten kann, müssen Mittel zur Beschränkung des Ansaugdrucks vorgesehen werden. Besonders geeignet ist hierzu ein druckbegrenzendes Expansionsventil; andererseits kann aber auch eine

discharge temperatures, which are detrimental to lubricating oil, refrigerant and motor winding insulation, the compressor must not operate below the suction pressures which correspond to the saturated vapour temperature limit on the performance graphs. The limits vary according to the refrigerants used, the condensing temperatures, and the degree of suction gas superheat.

If, due to reduction in plant duty, the use of throttling devices in the suction line, or any other cause, the compressors operate below limiting suction pressures, provision must be made for a corresponding reduction in suction vapour superheat.

The methods available for minimizing suction vapour superheating at the compressor are omitting the heat exchanger and insulating the entire length of the suction pipe to prevent heat pick-up from the atmosphere. In extreme cases liquid refrigerant injection into the suction line may be necessary.

Compressor cooling – It is necessary at all times to provide cooling for the electric motor. This can be accomplished by directing air on to the discharge side of the compressor housing either by positioning the compressor in the wake of the condenser fan or providing an independent fan to produce a minimum air flow of 152 m³/min (500 ft³/min). Alternatively, the compressor can be cooled by passing water through a cooling coil of copper pipe formed around the motor housing.

Lubricating system – Positive lubrication is provided via a twin blade oil propeller, (except on the L400/0062 which is fitted with a reversible positive displacement oil pump). This propeller rotates with the compressor shaft to lift oil into a reservoir located above the shaft centre line, from which a constant supply of oil is drawn through the shaft oilways to feed the bearings and pistons.

Lubricating oil – The compressors are charged with a full working charge of lubricating oil necessary for the proper lubrication of the bearings and moving parts.

Additional oil at the approximate rate of 0.5 litres for each 4.5 kg of system refrigerant charge should be introduced into the crankcase to allow for the amount of oil which will remain continuously in the system.

Care must be taken to ensure that the additional oil is clean, deaerated, and moisture free, and it should only be taken from a sealed can.

The following lubricating oils are compatible and approved for use in 'L' compressors:

Texaco Capella Oil 32
Suniso 3GS
Mobil Gargoyle Arctic 155
Duckhams Zeroflow 4
BP Energol LPT65
Burmah Castrol Icematic 266
Virginia 150 (Blue Cap)
Total Lunaria 20
Shell Clavus 32

Oil separators – Depending on the system design, the use of an oil separator may be necessary. This applies particularly to the use of R502, and all systems using R22 when evaporating below -12°C and R12 when evaporating below -35°C. In these cases an oil separator of sufficient capacity to retain the entire crankcase charge of lubricating oil

conduite d'aspiration.

Température des gaz – Afin d'éviter des températures excessives des gaz de refoulement qui nuisent à l'huile de lubrification, fluide frigorigène et isolation de bobinage, ne jamais utiliser le compresseur aux pressions des gaz aspirés inférieures à celles qui correspondent à la limite de température de vapeur saturée indiquée sur les courbes de puissance. Cette limite varie selon le frigorigène utilisé, la température de condensation et la quantité de surchauffe des gaz aspirés.

Si, à la suite d'une diminution de la capacité demandée par l'installation, ou de l'utilisation d'un dispositif d'étranglement dans la conduite d'aspiration ou de toute autre raison, le compresseur est utilisé aux pressions des gaz aspirés en dessous de la condition limite, il faut prévoir une diminution pareille de la surchauffe des gaz aspirés.

On peut réduire au minimum la surchauffe de la vapeur d'aspiration dans le compresseur en supprimant l'échangeur thermique et en isolant la conduite d'aspiration sur toute sa longueur afin d'éviter qu'elle n'absorbe de la chaleur ambiante. Dans des cas extrêmes, l'injection de réfrigérant liquide dans la conduite d'aspiration peut être nécessaire.

Refroidissement du compresseur – Il faut toujours que le moteur soit suffisamment refroidi. Ceci peut se faire en dirigeant un jet d'air sur le côté refoulement du compresseur, soit en le plaçant dans le courant d'air du ventilateur de condenseur, soit en équipant le compresseur d'un ventilateur séparé capable d'assurer une vitesse d'air minimum de 152 m³/min. Autrement le compresseur peut être refroidi par un serpentin d'eau monté autour de la section moteur du compresseur.

Lubrification – La lubrification est assurée par une hélice à deux ailettes (sauf dans le modèle L400/0062 qui est équipé d'une pompe à huile réversible) qui tourne sur l'arbre du compresseur et refoule l'huile dans un réservoir situé en surplomb, réservoir d'où l'huile s'écoule par les galeries de l'arbre pour lubrifier les paliers et pistons.

Huile de lubrification – Les compresseurs reçoivent, en usine, une charge d'huile suffisante à assurer la bonne lubrification du compresseur. Pour tenir compte de la quantité d'huile qui restera dans la tuyauterie de l'installation, de l'huile supplémentaire sera introduite dans le carter du compresseur au régime de 0,5 litre par 4,5 kg de fluide frigorigène utilisé dans le système.

Il faut assurer que cette huile soit propre, déaérée, sans humidité et prise dans un bidon étanche.

Nous conseillons l'utilisation des huiles suivantes:

Texaco Capella Oil 32
Suniso 3GS
Mobil Gargoyle Arctic 155
Duckhams Zeroflow 4
BP Energol LPT65
Burmah Castrol Icematic 266
Virginia 150 (Blue Cap)
Total Lunaria 20
Shell Clavus 32

Séparateurs d'huile – Selon la conception de l'installation, l'emploi d'un séparateur d'huile peut être nécessaire. Ceci est surtout le cas pour les installations au R502 et celles utilisant le R22 aux températures

zweckmäßige Drosselvorrichtung in die Saugleitung eingebaut werden.

Gastemperatur – Zur Vermeidung übermäßig hoher Drucktemperaturen, die für Schmieröl, Kältemittel und Motorwicklungs-Isolierung schädlich sind, darf der Kompressor nicht unterhalb der Ansaugdrücke arbeiten, die den Sättigungsdampf-Temperaturgrenzen in den Leistungskurven entsprechen. Diese Grenzen variieren je nach dem benutzten Kältemittel, den Verflüssigungstemperaturen und dem Überhitzungsgrad des Ansauggases.

Wenn wegen Herabsetzung der Anlageleistung, Anwendung von Drosselrichtungen oder aus irgendeinem anderen Grunde die Kompressoren unterhalb der unteren Grenze für den Ansaugdruck arbeiten, muß dafür gesorgt werden, daß die Überhitzung des Ansaugdampfes entsprechend verringert wird.

Methoden zur Herabsetzung der Überhitzung des Ansaugdampfes sind Weglassen des Wärmeaustauschers und Isolieren der gesamten Saugleitung zwecks Verhütung von Wärmeaufnahme aus der Umgebungsluft. In extremen Fällen kann Einspritzen von flüssigem Kältemittel in die Saugleitung erforderlich sein.

Kompressorkühlung – Der Elektromotor muß dauernd gekühlt werden. Dies kann durch einen Luftstrom auf die Druckseite des Kompressorgehäuses geschehen, indem man entweder den Kompressor im Abstrom des Verflüssiger-Ventilators anbringt oder einen weiteren Ventilator mit einem Mindest-Luftstrom von 152 m³/min vorsieht. Wahlweise kann der Kompressor mittels einer um das Motorgehäuse gewickelten, wasserdurchflossenen Kupferrohrschlange gekühlt werden.

Schmiersystem – Die zwangsläufige Schmierung erfolgt durch eine doppel-flügelige Ölschleuder (außer beim L400/0062, der mit einer drehrichtungs-unabhängigen Ölpumpe ausgestattet ist). Die Schleuder rotiert mit der Kompressorwelle und fördert das Öl in einen oberhalb der Mittellinie der Welle angebrachten Behälter, aus dem es durch die Bohrungen in der Welle zu den Lagern und Kolben gelangt.

Schmieröl – Die Kompressoren sind mit einer für die einwandfreie Schmierung der Wellen und beweglichen Teile ausreichenden vollen Betriebsfüllung versehen. Zur Aufrechterhaltung des Ölstandes im System ist eventuell zusätzliches Öl in einer Menge von etwa 0,5 Liter je 4,5 kg Kältemittelfüllung in das Kurbelgehäuse einzufüllen.

Es ist sorgfältig darauf zu achten, daß hierfür nur sauberes, luft- und feuchtigkeitsfreies Öl verwendet wird, das einer versiegelten Dose zu entnehmen ist.

Die folgenden Schmieröle sind kompatibel und zugelassen:

Texaco Capella Oil 32
Suniso 3GS
Mobil Gargoyle Arctic 155
Duckhams Zeroflow 4
BP Energol LPT 65
Burmah Castrol Icematic 266
Virginia 150 (Blue Cap)
Total Lunaria 20
Shell Clavus 32

Ölabscheider – Je nach Systemauslegung kann der Einsatz eines Ölabscheiders erforderlich werden. Dies ist besonders der

should be fitted. In addition, an oil separator should be used when the design of the system is such that long off-cycles are anticipated without pump down facilities or when the total refrigerant charge in kilogrammes exceeds six times the standard oil charge of the compressor in litres.

In all cases the returning oil must be taken directly into the crankcase through an oil filling plug and provision made to prevent condensed refrigerant entering the sump from the oil separator during the off-cycle.

Oil return – The pipework of the entire system must be so designed and installed as to ensure that lubricating oil returns readily to the compressor. Reference to the relevant chapter in the Application section of the ASHRAE Data Book is strongly recommended as a guide to good pipework design and practice.

Oil pressure safety switch – An oil pump is fitted to the L400/0062, which ensures a liberal flow of oil to all bearings even under extreme operating conditions.

The design of the compressor is such that the lubricating system functions with a relatively low oil pressure. The pressure is sufficient to produce the necessary flow of oil but is lower than the minimum setting of commercially available oil pressure differential safety switches.

Crankcase and oil separator heaters – Heaters must be fitted to the crankcase and oil separator on all applications when the compressor or oil separator is liable at any time to become as cold as the evaporator, condenser or receiver. Crankcase heaters are not necessary when a full pump-down cycle is employed but a heater for the oil separator may still be required.

Suitable 100 W heaters for the compressor crankcase are available as optional extras. The heaters should be wired to be energised during the compressor off-cycle and they may be conveniently fed from a normally closed contact on the starter or contactor.

Starting – In order to protect the life of the compressor, it is recommended that the maximum number of starts per hour is limited to twenty. If, due to the application, a greater number of starts per hour is anticipated, some external form of capacity control should be used to avoid short-cycling.

Electric motors – All motor windings have Class 'B' insulation and are generously rated to permit compressors to be used over a wide range of operating conditions.

All motors are suitable for direct-on-line starting. L400 and L401 compressors can also be supplied with motors suitable for star/delta starting.

Electrical connections – The stator leads are brought out through hermetic terminals of the "Glasmetic" type to an electrical box mounted on top of the motor housing, in which terminals are provided for power supply connection and control circuits.

Motor protection – Single phase compressors are fitted with a temperature sensitive self-resetting overload cut-out. External current sensitive protection having approved quick-trip characteristics must be provided and a suitable starter is available as

d'évaporation inférieures à -12°C , ou le R12 aux températures d'évaporation inférieures à -35°C . Il faut prévoir un séparateur d'huile d'une capacité suffisante à contenir la charge d'huile entière du carter. On utilisera également un séparateur d'huile dans le cas où l'installation est telle que le compresseur ne tournera pas pendant de longues périodes et qu'il n'existe pas de possibilité d'évacuation, ou que la charge totale en frigorigène en kilogrammes est supérieure à six fois la charge normale d'huile du compresseur en litres.

Dans tous les cas, l'huile doit rentrer directement au carter du compresseur et il faut éviter que le frigorigène condensé puisse quitter le séparateur pour rentrer dans le carter en période de non-fonctionnement du compresseur.

Retour d'huile – La tuyauterie du système doit être conçue et installée de façon à assurer un abondant retour d'huile au compresseur. Nous conseillons fortement que l'installation soit étudiée et installée suivant les recommandations du "ASHRAE data book".

Pressostat différentiel d'huile – La pompe à huile dont est équipé le compresseur L400/0062 garantit une ample alimentation d'huile à tous les paliers, même dans les conditions d'utilisation les plus défavorables.

La conception du compresseur garantit le fonctionnement normal du circuit de lubrification par pression d'huile relativement faible. La pression est suffisante à assurer le débit d'huile requis mais est inférieure au point de réglage minimum des pressostats d'huile d'usage courant.

Résistances de carter et de séparateur d'huile – Si la température du carter du compresseur ou du séparateur d'huile peut descendre en dessous de celle d'un des constituants de l'installation (évaporateur, condenseur ou réservoir de liquide), il est conseillé de prévoir des résistances chauffantes.

Une résistance de carter n'est pas obligatoire lorsqu'il y a un système d'évacuation complète de frigorigène, mais un chauffage sera éventuellement nécessaire pour le séparateur d'huile.

Des résistances de carter 100W convenables sont fournies sur demande. Ces résistances seront branchées de manière à être mises en marche lorsque le compresseur est à l'arrêt, ce qui peut facilement être réalisé au moyen d'un relais normalement fermé sur le contacteur ou le démarreur du moteur.

Démarrage – Afin de ménager la durée de service du compresseur, on limitera à 20 le nombre de démarrages par heure. Si les circonstances d'exploitation donnent à prévoir la possibilité d'un nombre de démarrages supérieur à ce chiffre, il conviendra de prévoir un système extérieur de régulation de puissance pour éviter le court-cyclage du compresseur.

Moteurs électriques – Tous les bobinages de moteur sont isolés selon la norme B et leur homologation autorise l'emploi des compresseurs dans des conditions très

Fall bei allen Systemen mit Kältemittel R502, bei Systemen mit R22 bei Verdampfungstemperaturen unter -12°C , und bei Systemen mit R12 bei Verdampfungstemperaturen unter -35°C .

In solchen Fällen ist ein Ölabscheider vorzusehen, welcher ausreichende Kapazität hat, die gesamte Standardölfüllung des Kompressors aufzunehmen.

Ferner ist ein Ölabscheider zu empfehlen, wenn lange Standzeiten zu erwarten sind und keine Abpumpschaltung möglich ist, oder wenn die gesamte Kältemittelfüllung mehr als das Sechsfache der Standardölfüllung des Kompressors beträgt.

Auf alle Fälle muss das Öl direkt zum Kurbelgehäuse z. B. über ein Ölfüllnippel zurückgeführt werden. Es muss sichergestellt sein, daß während der Stillstandzeiten kein kondensiertes Kältemittel in das Kurbelgehäuse gelangt.

Ölrücklauf – Das Leitungssystem für die Gesamtanlage ist so zu konstruieren und zu verlegen, daß das Schmieröl ungehindert zum Kompressor zurücklaufen kann. Wertvolle Hinweise für gute Rohrleitungspraxis finden sich im Anwendungsteil des ASHRAE – Datenbuches.

Öldruck-Sicherheitsschalter – Der L400/0062 ist mit einer Ölpumpe ausgerüstet, die alle Lager reichlich mit Öl versorgt, selbst unter extremen Betriebsbedingungen, z. B. auf Schiffen bei schwerem Seegang.

Der Kompressor ist so konstruiert, daß das Schmieröl mit einem relativ niedrigen Öldruck arbeitet. Der Druck reicht zur Erzeugung des erforderlichen Ölflusses aus, er ist jedoch kleiner als die niedrigste Einstellung handelsüblicher Öldruck-Differenzschalter.

Kurbelwannen- und Ölabscheiderheizung – In allen Anwendungsfällen müssen Kurbelgehäuse und Ölabscheider mit einer Heizung versehen werden, wenn sie zeitweilig so kalt werden können wie der Verdampfer, der Verflüssiger oder der Sammler, so daß die Gefahr einer Kältemittel-Abwanderung besteht. Bei Einsatz mit Abpumpschaltung darf die Kurbelwannenheizung entfallen. Eine Beheizung des Ölabscheiders ist aber in solchen Fällen eventuell vorzusehen.

Eine 100 W-Kurbelwannenheizung (wahlweise lieferbar) ist an einen Ruhekontakt im Anlasser bzw. Schutz anzuschließen, um Energiezufuhr während der Abschaltzeiten des Kompressors sicherzustellen.

Anlassen – Zur Schonung des Kompressors empfiehlt es sich, die Zahl der Anlassvorgänge auf ein Maximum von zwanzig in der Stunde zu beschränken. Wenn der Anwendungszweck eine größere Schalthäufigkeit erwarten läßt, ist externe Leistungsregelung in irgendeiner Form vorzusehen, um ein Pendeln zu vermeiden.

Elektromotoren – Alle Motorwicklungen haben Isolation der Klasse B und sind so reichlich bemessen, daß die Kompressoren in einem weiten Bereich von Betriebsbedingungen benutzt werden können.

Direktanlauf ist bei allen Kompressoren möglich. Bei dem L400 und dem L401 ist Sterndreieckanlauf wahlweise erhältlich.

Elektrische Anschlüsse – Die Ständer-

an optional extra.

All dual-voltage models up to and including model L300 are fitted with a temperature sensitive self-resetting overload cut-out. External current sensitive protection having approved quick-trip characteristics must be provided and a suitable starter is available as an optional extra. Single voltage band three phase compressors up to and including L300 are fitted with a temperature and current sensitive self-resetting overload cut-out connected at the star point of the motor windings. A suitable contactor, without overloads, can be supplied as an optional extra.

Inherent motor protection is available on request for dual voltage band three phase compressors and is supplied as standard for all L400 and L401 compressors. This is ensured by thermistors implanted in each phase winding continuously to monitor the temperature up to a predetermined level. At this point they cause the motor contactor (which can be supplied as an optional extra) to disconnect the supply from the motor and to restore it only when the temperature of the windings falls to a safe level. A transistorised low-voltage circuit actuates a miniaturised relay (included) which forms a switch in the main control circuit.

In cases where the electrical supply network is such that occasional loss of supply phase can occur, additional single-phasing protection devices should be fitted. Either external overloads with quick trip characteristics or separate phase-loss protectors, both with manual reset, are preferable.

variées. Tous les compresseurs type 'L' sont équipés de moteurs qui conviennent au démarrage direct. Les moteurs des compresseurs L400 et L401 peuvent également être fournis en version démarrage étoile-triangle.

Branchements électriques – Les fils du stator sont raccordés par des bornes étanches de type Glasmatic à une boîte à bornes au dessus du moteur comprenant des bornes de raccordement de l'alimentation et des circuits de régulation et commande.

Protection moteur – Les compresseurs monophasés de la série 'L' sont équipés d'un disjoncteur de sécurité à auto-réenclenchement, sensible à la température. Il faut prévoir un relais extérieur à déclenchement instantané de protection contre les surcharges. Un démarreur convenable peut être fourni sur demande.

Tous les compresseurs à 220/380 V / 3 ph / 50 Hz jusqu'au modèle L300 sont équipés d'un disjoncteur de sécurité à auto-réenclenchement, sensible à la température. Il faut prévoir un relais extérieur à déclenchement instantané de protection contre les surcharges. Un démarreur convenable peut être fourni sur demande.

Les compresseurs à 380 V / 3 ph / 50 Hz jusqu'au modèle L300 sont équipés d'un disjoncteur de sécurité à auto-réenclenchement, sensible à la température et au courant et couplé à l'étoile des enroulements du moteur. Un contacteur approuvé peut être fourni sur demande.

Tous les compresseurs à 220 / 380 V / 3ph / 50 Hz peuvent être équipés, sur demande, d'une protection moteur intégrale par thermistances. Tous les compresseurs L400 et L401 sont équipés d'une protection moteur intégrale par thermistances incorporées aux bobinages des trois phases qui contrôlent la température jusqu'à une limite déterminée. Une fois ce niveau dépassé, les thermistances coupent l'alimentation du moteur par moyen du contacteur et ne permettent son rétablissement que lorsque la température des bobinages est retombée en dessous de cette limite. Un circuit basse tension transistorisé commande un relais miniaturisé monté sur le compresseur.

Quand le réseau d'alimentation admet la possibilité de pertes de phases, il convient d'installer des dispositifs de protection supplémentaires. Dans ce cas, l'emploi de disjoncteurs extérieurs à déclenchement instantané ou de dispositifs de protection contre perte de phase, avec réenclenchement manuel dans les deux cas, est préconisé.

leitungen werden über hermetische Durchführungen vom "Glasmatic"-Typ zu einem auf dem Motorgehäuse angebrachten Kasten geführt, der Klemmen zum Anschließen der Stromversorgung und der Regelkreise enthält.

Motorschutz – Einphasen-Kompressoren der L-Serie sind mit einem temperatur-empfindlichen, selbstrückstellenden Thermoschutzschalter versehen. Ein externer stromempfindlicher Überstromauslöser mit genehmigter Schnellauslösecharakteristik ist vorzusehen. Ein passender Anlasser ist als wahlweise Sonderausstattung lieferbar.

Alle Typen Doppelspannung (220 V/380 V) bis Modell L300 einschließlich haben einen temperaturempfindlichen, selbstrückstellenden Thermoschutzschalter. Ein externer stromempfindlicher Überstromauslöser mit genehmigter Schnellauslösecharakteristik ist vorzusehen; ein passender Anlasser ist als wahlweise Sonderausstattung lieferbar. Als Alternative kann Thermistorvollschutz geliefert werden, wobei ein externer Überstromauslöser nicht erforderlich ist.

Dreiphasen-Kompressoren für nur einen Spannungsbereich sind mit einem temperatur- und stromempfindlichen Thermoschutzschalter versehen, der im Sternpunkt der Motorwicklungen eingeschlossen ist. Ein passendes Schaltschütz ohne Überlastungsschutz kann als wahlweise Sonderausstattung geliefert werden.

Für den Schutz der Kompressoren L400 und L401 sorgen Thermistoren, die in jede einzelne Phasenwicklung eingebaut sind und laufend die Temperatur bis zu einer vorgegebenen Höhe überwachen. Bei diesem Wert veranlassen sie das als wahlweise Sonderausstattung lieferbare Motorschütz zur Abschaltung der Motorspeisespannung, die erst wieder zugeschaltet wird, wenn die Wicklungstemperatur auf einen sicheren Wert gefallen ist. Eine transistorisierte Niederspannungsschaltung betätigt ein eingebautes Kleinrelais, das als Schalter im Hauptregelkreis wirkt.

Wenn wegen besonderen Eigenschaften der Netzes mit gelegentlichen Phasenausfall zu rechnen ist, sind zusätzliche Einphasenschutzvorrichtungen vorzusehen, vorzugsweise externe Schnellauslöser oder separate Phasenausfallsicherungen, beide mit Handrückstellung.

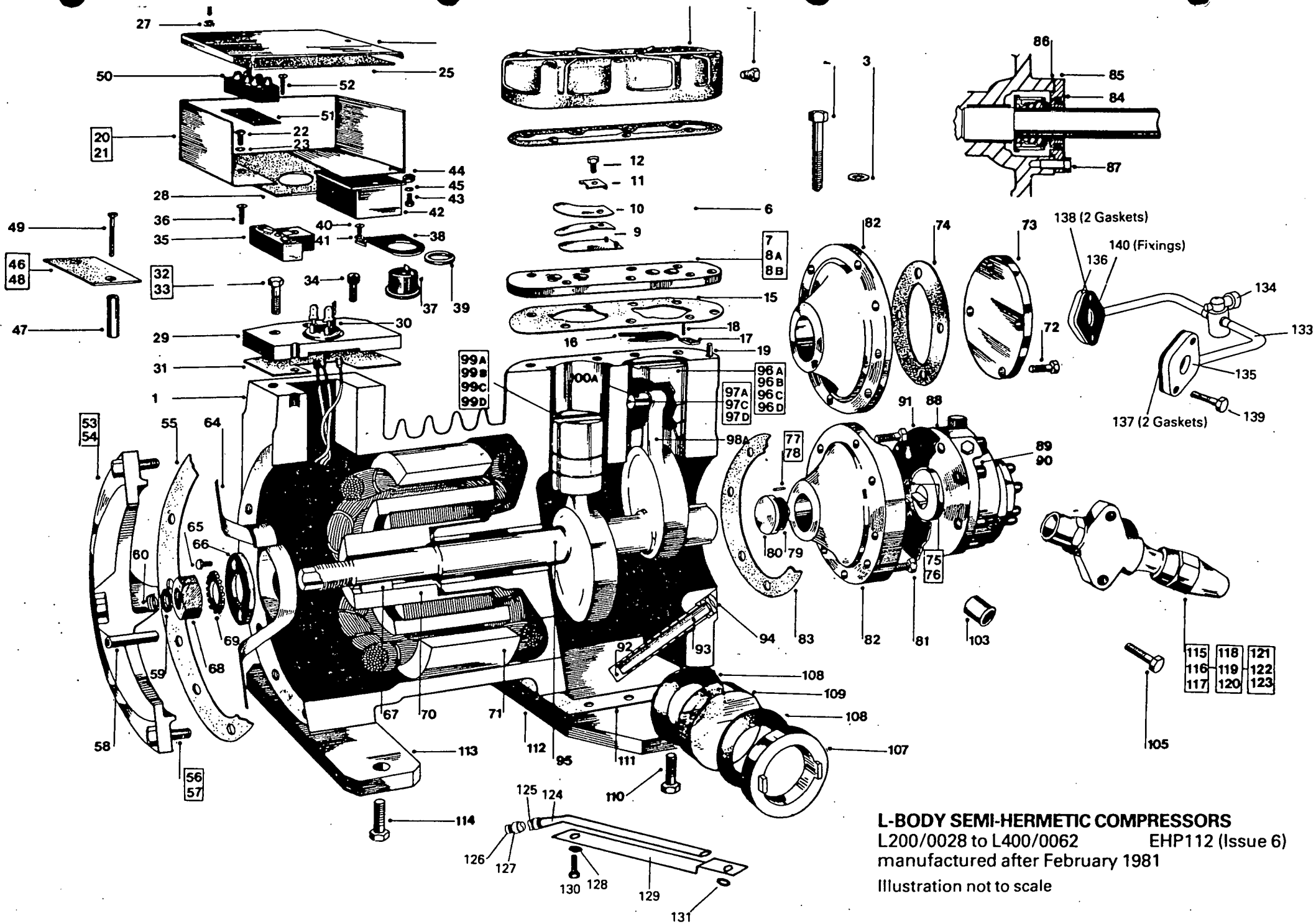

L-BODY SEMI-HERMETIC COMPRESSORS
 L200/0028 to L400/0062 EHP112 (Issue 6)
 manufactured after February 1981
 Illustration not to scale

50 Hz

L-body Semi-hermetic Compressors

PARTS LIST

L200/0028 to L400/0062

EHP112 (Issue 6)

manufactured after February 1981

Compressor Part No.	Model	Voltage	Phase	Hz	Stator Part No.	Rotor Part No.	Klixon Part No.
7170/1248	L200/0028	210/240-360/420	3	50	27170/7227	27170/7228	TP
57170/6398	L200/0037	220/240	1	50	27170/7899	27170/7919	27110/0016
57170/6399	L200/0037	200/220	1	50	27170/7900	27170/7919	27110/0016
57170/0160	L200/0037	480	1	50	27170/7901	27170/7919	27110/0016
57170/7803	L200/0037	360/420	3	50	27170/7893	27170/7916	27110/0093
57170/6401	L200/0037	210/240-360/420	3	50	27170/7893	27170/7916	27110/0016
57170/6489	L200/0042	220/240	1	50	27170/7899	27170/7919	27110/0016
57170/6488	L200/0042	200/220	1	50	27170/7900	27170/7919	27110/0016
57170/0161	L200/0042	480	1	50	27170/7901	27170/7919	27110/0016
57170/7804	L200/0042	360/420	3	50	27170/7893	27170/7916	27110/0093
57170/6491	L200/0042	210/240-360/420	3	50	27170/7893	27170/7916	27110/0016
57170/6402	L200/0050	220/240	1	50	27170/7899	27170/7919	27110/0016
57170/6403	L200/0050	200/220	1	50	27170/7900	27170/7919	27110/0016
57170/0176	L200/0050	480	1	50	27170/7901	27170/7919	27110/0016
57170/7805	L200/0050	360/420	3	50	27170/7893	27170/7916	27110/0093
57170/6405	L200/0050	210/240-360/420	3	50	27170/7893	27170/7916	27110/0016
57170/0186	L300/0037	220/240	1	50	27170/7904	27170/7920	27110/0016
57170/0187	L300/0037	200/220	1	50	27170/7905	27170/7920	27110/0016
57170/0190	L300/0037	480	1	50	27170/7906	27170/7920	27110/0016
57170/7417	L300/0037	360/420	3	50	27170/7910	27170/7917	27110/0073
				50	27173/7952	27173/7955	
57170/0189	L300/0037	210/240-360/420	3	50	27170/7910	27170/7917	27110/0016
				50	27173/7952	27173/7955	
57170/1245	L300/0042	220/240	1	50	27170/7904	27170/7920	27110/0016
57170/1244	L300/0042	200/220	1	50	27170/7905	27170/7920	27110/0016
57170/7984	L300/0042	480	1	50	27170/7906	27170/7920	27110/0016
57170/8210	L300/0042	360/420	3	50	27170/7910	27170/7917	27110/0073
				50	27173/7952	27173/7955	
57170/7983	L300/0042	210/240-360/420	3	50	27170/7910	27170/7917	27110/0016
				50	27173/7852	27173/7955	
57170/6406	L300/0050	220/240	1	50	27170/7904	27170/720	27110/0016
57170/6407	L300/0050	200/220	1	50	27170/7905	27170/7920	27110/0016
57170/0162	L300/0050	480	1	50	27170/7906	27170/7920	27110/0016
57170/7416	L300/0050	360/420	3	50	27170/7910	27170/7917	27110/0073
				50	27173/7952	27173/7955	
57170/6409	L300/0050	210/240-360/420	3	50	27170/7910	27170/7917	27110/0016
				50	27173/7952	27173/7955	
57170/6410	L300/0062	220/240	1	50	27170/7904	27170/7920	27110/0016
57170/6411	L300/0062	200/220	1	50	27170/7905	27170/7920	27110/0016
57170/0177	L300/0062	480	1	50	27170/7906	27170/7920	27110/0016
57170/7419	L300/0062	360/420	3	50	27170/7910	27170/7917	27110/0073
				50	27173/7952	27173/7955	

57170/0092	L300/0062	210/240-360/420	3	50	27170/7910	27170/7917	27110/0016
57170/1246	L400/0050	360/420	3	50	27173/7952	27173/7955	
57170/1247	L400/0050	210/240-360/420	3	50	27170/7221	27170/7223	TP
57170/1246	L400/0050	360/420-SD	3	50	27170/7222	27170/7223	TP
57170/1247	L400/0050	210/240-SD	3	50	27170/7221	27170/7223	TP
57170/7224	L400/0062	360/420	3	50	27170/7222	27170/7223	TP
57170/6756	L400/0062	210/240-360/420	3	50	27170/7221	27170/7223	TP
57170/7224	L400/0062	360/420 SD	3	50	27170/7222	27170/7223	TP
57170/6756	L400/0062	210/240 SD	3	50	27170/7221	27170/7223	TP
57170/8305	L401/0062	360/420	3	50	27170/7222	27170/7223	TP
57170/8304	L401/0062	210/240-360/420	3	50	27170/7221	27170/7223	TP
57170/8305	L401/0062	360/420 SD	3	50	27170/7222	27170/7223	TP
57170/8304	L401/0062	210/240 SD	3	50	27170/7221	27170/7223	TP

EXCEPT WHERE STATED ALL PARTS ARE COMMON

Item No.	Part No.	Description	Qty.
1	37170/6309	Body & Bearing Assy 1.7/8" Bore — L200/0037, L300/0037,	1
	37170/6310	Body & Bearing Assy 2" Bore — L200/0028, ES200/0042, L200/0042, L300/0042	1
	37170/6311	Body & Bearing Assy 2.3/16" Bore — L200/0050, L300/0050, L400/0050	1
	37170/6312	Body & Bearing Assy 2.7/16" Bore — L300/0062, L401/0062	1
	37170/7394	Body & Bearing Assy 1.7/8" Bore — L(SB) 200/0037	1
	37170/7395	Body & Bearing Assy 2" Bore — L(SB) 200/0042	1
	37170/7396	Body & Bearing Assy 2.3/16" Bore — L(SB) 200/0050, L(SB) 300/0050	1
	37170/7397	Body & Bearing Assy 2.7/16" Bore — L(SB) 300/0062, L400/0062	1
CYLINDER HEAD AND VALVE PLATE TO BODY ASSEMBLY			
2	27170/6449	Screw Hex Hd 3/8" 24 UNF 2A x 2.1/4" } Securing Cylinder Head	9
3	WA110060	Washer Plain 3/8" }	9
4	17170/8247	Cylinder Head	1
5	27170/6453	1/8" Briggs Plug — Cylinder Head	2
6	27170/8248	Gasket — Cylinder Head	1
7	37170/8245	Valve Plate Assy (Large) — L300/0062, L400/0062, L401/0062 L200/0050, L300/0050, L400/0050	1
	37170/8249	Valve Plate Assy (Small) — L200/0037, L300/0037, L200/0042	1
8A	17170/8237	Valve Plate — Small	1
8B	17170/8238	Valve Plate — Large	1
9	27170/4189	Discharge Valve Reed	4 for 8A, 8 for 8B
	or		
	27170/4190	Discharge Reed (Flexed)	2 for 8A, 4 for 8B
10	27170/7760	Discharge Valve Reed Retainer	2 for 8A, 4 for 8B
11	27170/6244	Bolt Lock Washer	2 for 8A, 4 for 8B
12	27170/8250	Bolt	2 for 8A, 4 for 8B
15	27170/8239	Gasket Valve Plate — 0037 Models	1
	27170/8240	Gasket Valve Plate — 0028, 0042 models	1
	27170/8279	Gasket Valve Plate — 0050 Models	1
	27170/8278	Gasket Valve Plate — 0062	1
16	27170/6169	Reed Suction Valve — 0028 — 0037 — 0042 Models	1
	27170/4195	Reed Suction Valve — 0050 — 0062 Models	1
17	27170/6239	Suction Valve Pad	2
18	27170/6227	Suction Valve Locating Pin	4
19	27170/6228	Dowel Pin Valve Plate to Body	2
TERMINAL AND OVERLOAD ASSEMBLY			
20	57170/9743	Terminal Box Assy — Klixon Protected Models	1
21	27170/9744	Terminal Box Assy — Thermistor Protected Models	1
22	UMA101PR05	M/C Screw 10 — 32 UNF 2A x 5/16" } Fixing Terminal Box	4
23	UWS021	Washer Shakeproof 10 UNF }	4
24	57170/6477	Terminal Box Cover	1
25	27170/6482	Insulation — Terminal Box Cover	1
26	SA101PR06	M/C Screw 10 — 32 UNF x 5/16" } Fixing Terminal Box Cover	2
27	WE702101	Washer Shakeproof 10 UNF }	2
28	27170/7883	Insulating Gasket — Terminal Plate — all voltages except 480 volts	1
	27170/9826	Insulating Gasket — Terminal Plate — 480 volts only	1

29	37170/7878	Terminal Mounting Plate Assy (3 Term) 200/220/1/50 & 220/240/1/50	1
	37170/7879	Terminal Mounting Plate Assy (6 Term) 480 V Single Phase, Std Three Phase & Three Phase Dual Voltage	1
	37170/7880	Terminal Mounting Plate Assy (5 term) Three Phase Dual Voltage (SB)	1
	37170/7881	Terminal Mounting Plate Assy (6 Term) 200/220/3/60 & 550/600/3/60	1
	37170/7882	Terminal Mounting Plate Assy (6 Term) Thermistor Protected Models	1
30	27170/6718	Fusite Terminal — Thermistor Protected Models	2
31	27170/6141	Gasket — Terminal Plate	1
32	27170/6442	M/C Screw 5/16" 24 UNF 2A x 1.1/8"	4
33	27170/6443	M/C Screw 5/16" 24 UNF 2A x 1.3/8"	1
34	27170/6456	Screw Socket Hd. 5/16" 24 UNF 2A x 3/4"	2
35	27170/6241	Terminal Connector	1
36	UMA109PR05	Screw Pan Recess Hd 10 — 32 UNF 2A x 5/16" — Terminal Connector	3
37	See front sheets	Motor Protector (Klixon)	1
37A	27170/7877	Klixon Mounting Plate	1
38	57170/6148	Retaining Plate — Motor Protector 3/4"	1
	57170/7095	Retaining Plate — Motor Protector 1"	1
39	27170/6149	Insulating Sleeve — Motor Protector 3/4"	1
	27170/7097	Insulating Sleeve — Motor Protector 1"	1
40	UMA101PR08	M/Screw 10 — 32 UNF — 2A x 1/2" — Fixing Retaining Plate	2
40A	UMA101CR08	M/Screw C/sk Hd 10 — 32 UNF - 2A x 1/2"	2
41	UWS121	Washer — Shakeproof — Fixing Retaining Plate	2
42	27170/4386	Thermistor Control Unit —	1
42A	27080/0686	Spare Fuse 2 amp	1
43	UMC061PR08	M/C Screw 6 — 32 UNC x 1/2"	2
44	UNC061H	Nut Hex 6 — 32 UNC	2
45	WS091	Washer Shakeproof No. 6	2
46	27170/6457	Terminal Board	1
47	27170/6463	Terminal Board Spacer	2
48	27170/6464	Terminal Board Bush	2
49	UMA101P32	M/C Screw 10 — 32 UNF 2A x 2" — Fixing Board	2
50	27150/0135	Terminal Block — 6 Way — 20 Amp — Thermistor Protected Models	1
51	27170/7376	Insulation — Terminal Block	1
52	SA041PR12	S/M Screw Type 'A' No 4 x 3/4" — Fixing Terminal Block	2

} Fixing Terminal Mounting Plate

} Klixon Protected Models

MOTOR END

53	17172/6041	Motor End Cover (Cast Aluminium)	1
54	17170/6652	Splasher Baffle	1
55	27170/6114	Gasket Motor End Cover Plate	1
56	27170/6447	M/C Screw 3/8" 24 UNF 2A x 1.1/8"	12
57	WA110060	Washer Plain 3/8"	12
58	27170/6222	Oil Tube (Not Pump Lubricated Models)	1
59	27170/6190	Rotor Thrust Washer (Not Extended Shaft & Pump Lubricated Models)	1
60	27170/6193	Rotor Thrust Spring (Not Extended Shaft & Pump Lubricated Models)	1
61	27170/6234	Thrust Washer (Extended Shaft & Pump Lubricated Models)	1
62	27170/6235	Tension Pin (Extended Shaft & Pump Lubricated Models)	1
63	17170/7382	Insert (Pump Lubricated Models)	1
64	37170/6328	Oil Splasher	1
65	UMC161C08	M/C Screw 1/4" 20 UNC 2A x 1/2" — Fixing Oil Splasher	2
66	17170/9738	Washer Eccentric Shaft to Rotor	1
67	17170/6226	Crankshaft Key	1
68	27170/6257	Nut 7/8" 14 UNF 2A	1
69	17170/9737	Washer Shakeproof 7/8"	1
70	see front sheets	Rotor	1
71	see front sheets	Stator	1

} Non-pump Lubricated Models

} Retaining Rotor

THRUST END AND CRANKCASE

72	27170/6439	M/C Screw 5/16" 24 UNF 2A x 3/4"	4	
73	17170/6052	Thrust Plate	1	
74	27170/6139	Gasket — Thrust Plate	1	
76	17170/7364	End Thrust Plug — (Pump Lubricated Models)	1	
77	27170/6250	Pin Spring — End Thrust Plug — (Not Extended Shaft & Pump Lubricated Models)	1	
78	27170/6235	Pin Spring — Oil Pump — (Pump Lubricated Models)	2	
79	27170/7366	End Thrust Crimp Spring (Not Extended Shaft Models)	1	
80	27170/7365	Thrust Plug — Retainer	1	
81	27170/6447	M/C Screw 3/8" UNF x 1.1/8" — Fixing Housing Cover & Bearing	8	
82	{	37170/6759	Housing Cover & Bearing — Not Extended Shaft & Pump Lubricated Models	1
		37170/6324	Housing Cover & Bearing — Extended Shaft Models	1
		37170/6760	Housing Cover & Bearing — Pump Lubricated Models	1
83	27170/6117	Gasket Housing Cover	1	
84	27170/6433	Shaft Seal Assy	1	
85	17170/6076	Seal Retaining Plate	} Extended Shaft Models	
86	27170/6140	Gasket Seal Retaining Plate		
87	27170/6438	M/C Screw 1/4" 28 UNF x 3/4" — Fixing Retaining Plate	6	
88	17170/4397	Oil Pump — Pump Lubricated Models	1	
89	27170/4097	M/C Screw 5/16" 18 UNC 2A x 3/4"	} Fixing Oil Pump	
90	27170/4170	M/Screw 18 UNC 2A x 1.1/2"		
91	27170/4371	Gasket — Oil Pump	1	
92	27170/7367	Oil Filter	} Pump Lubricated Models	
93	27170/7368	Oil Filter Insert		
95	{	17170/6057	Eccentric Shaft — (Not Extended Shaft & Pump Lubricated Models)	1
		17170/6109	Eccentric Shaft — (Extended Shaft Models)	1
		37170/9788	Eccentric Shaft — Extension Piece Assy — (Pump Lubricated Models)	1
96A	37170/8259	Piston & Eccentric Rod Assy — 0037 Models (Comprising items 97A, 98A, 99A, 100A)	2	
97A	37170/6357	Piston Pin & Rivet Assy	2	
98A	17170/6790	Eccentric Rod	2	
99A	17170/8252	Piston	2	
100A	27170/6232	Piston Pin Crimp Spring	2	
96B	37170/8258	Piston & Eccentric Rod Assy — 0028, 0042 Models (Comprising items 97A, 98A, 99B, 100A)	2	
99B	17170/8251	Piston	2	
96C	37170/8260	Piston & Eccentric Rod Assy — 0050 Models (Comprising items 97C, 98A, 99C, 100A)	2	
97C	37170/6358	Piston Pin & Rivet Assy	2	
99C	17170/8254	Piston	2	
96D	37170/8261	Piston & Eccentric Rod Assy — 0062 Models (Comprising items 97D, 98A, 99D, 100A)	2	
97D	37170/6359	Piston Pin & Rivet Assy	2	
99D	17170/8255	Piston	2	

SUMP PLATE, OIL SIGHT GLASS AND SHUT-OFF VALVES

103	27170/8138	Screen — Suction Strainer	1	
106	27510/0695	Sight Glass Retainer	1	
107	27510/0563	Gasket Sight Glass	1	
108	27510/0562	Sight Glass	1	
109	27510/0564	Washer Sight Glass	1	
110	27170/6447	M/C Screw 3/8" 24 UNF 2A x 1.1/8" — Fixing Sump Plate	17	
111	27170/6111	Gasket — Sump Plate	1	
112	17170/6043	Sump Plate	1	
113	17170/9643	Mounting Foot	1	
114	27170/6447	M/C Screw 3/8" 24 UNF 2A x 1.1/8" — Fixing Mounting Foot	2	
115	{	27170/6426	Shut-off Valve 5/8" (Discharge) (HRP)	1
		or		
		27170/6640	Shut-off Valve 5/8" (Discharge) (Scott)	1
116	{	or		
		27171/6640	Shut-off Valve 5/8" (Discharge) (Primore)	1
116	27170/6144	Gasket Shut-off Valve 5/8"	1	
117	{	27170/6443	M/C Screw 5/16" 24 UNF 2A x 1.3/8" — Securing 5/8" Shut-off Valve (HRP)	2
		or		
		27170/6439	M/C Screw 5/16" 24 UNF 2A x 3/4" — Securing 5/8" Shut-off Valve (Scott & Primore)	2

118	{	27170/8142	Shut-off Valve 7/8" (Suction) (Nobis)	1
		or		
		27171/8142	Shut-off Valve 7/8" (Suction) (Henry)	1
119		27170/9815	Gasket Shut-off Valve 7/8"	1
120		27170/6450	Screw 1/2" UNF x 1.1/4" Securing 7/8" Suction Shut-off Valve	2
121	{	27170/8143	Shut-off Valve 1.1/8" (Suction) (Nobis)	1
		or		
		27171/8143	Shut-off Valve 1.1/8" (Suction) (Henry)	1
122		27170/9815	Gasket Shut-off Valve 1.1/8"	1
123		27170/6450	Screw 1/2" UNF x 1 1/4" — Securing 1.1/8" Shut-off Valve	2
124		27170/6421	Crankcase Heater — 100 W 240 V	1
125		27150/0201	Flexible Conduit — 16 mm	0.61 m
126		27150/0200	Adaptor 16 mm	2
127		27150/0202	Locknut 16mm	1
128		27150/0183	Washer 1" od x 3/4" id	
129		27170/6423	Retainer — Crankcase Heater	1
130		27170/6448	M/Screw 3/8" UNF x 1.1/4"	2
131		27200/0470	Washer Plain 3/8" UNF	2

STAR DELTA MODEL

132		27170/9764	Check Valve 5/8"	1
133		57170/4714	Unloading Valve Assembly Comprising Items 134 to 136	1
134		27170/4704	Solenoid Valve 7/8" Sporlan B1052	1
135		17170/4710	Flange 1.1/8"	1
136		17170/4711	Flange 5/8"	1
137		27170/4662	Gasket — 1.1/8" Flange	1
138		27170/4716	Gasket — 5/8" Flange	1
139		27170/6452	M/Screw 1/2" UNF x 3" — Securing 1.1/8" Shut-off Valve	2
140	{	27170/6443	M/Screw 5/16" UNF x 1.3/8" — Securing 5/8" Shut-off Valve (HRP)	2
		27170/6439	M/Screw 5/16" UNF x 1.3/4" — Securing 5/8" Shut-off Valve (Scott)	2

Note:

Compressor Designation: SB refers to Shipboard Model

STRÖTER DÜSSELDORF

STUFENLOSE GANZSTAHL-REGELTRIEBE

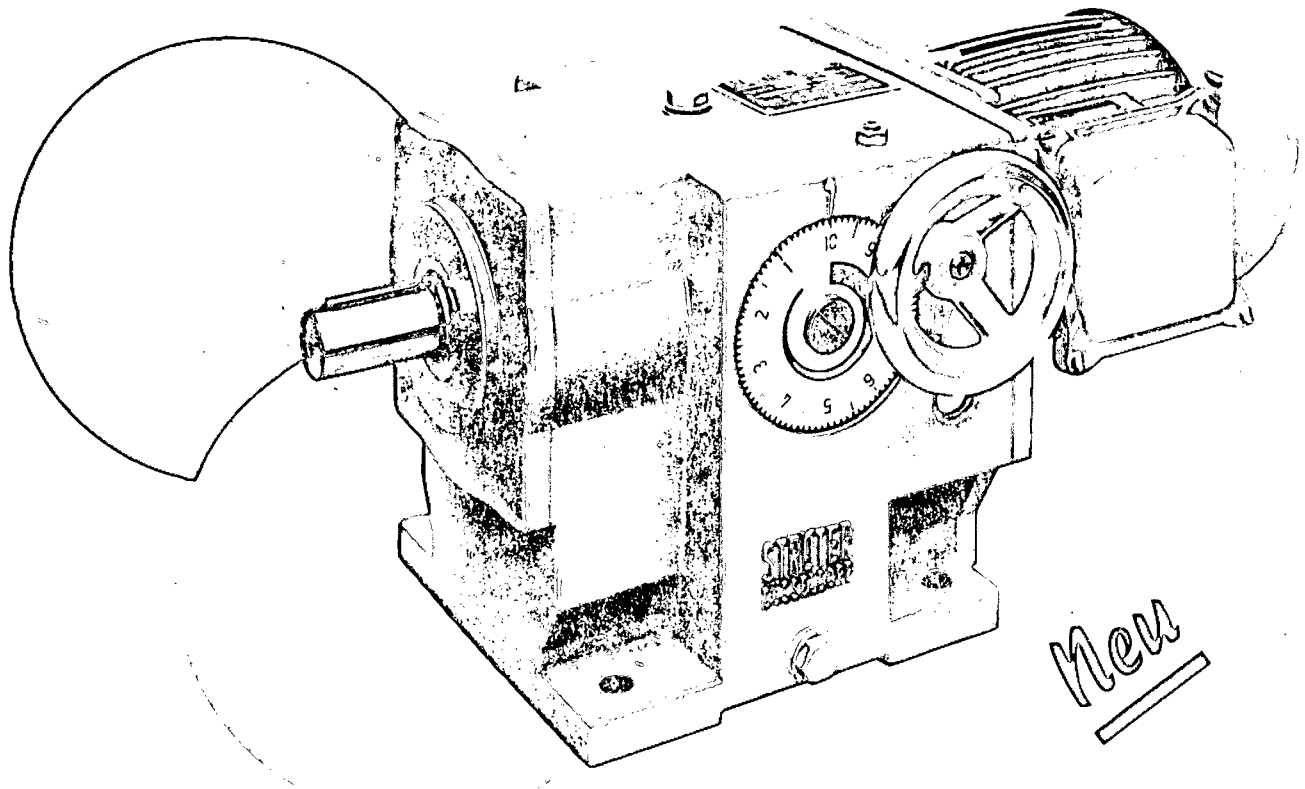







STRÖTER-Ganzstahl-Regeltrieb Typ A

Besondere Vorteile:

- Regelbereich 1:10
- Reibring aus Hartmetall
- kompakte Bauart
- vollkommen geschlossen
- keine beweglichen Außenteile
- Bauformen horizontal und vertikal
- im Lauf und im Stillstand verstellbar
- viele Drehzahlbereiche
- kurze Lieferzeiten

und was Sie noch
mehr interessiert:

Hans Ströter oHG - 4000 Düsseldorf - Getriebebau

Schmierstoff-Empfehlung für STRÖTER-Ganzstahl-Regelgetriebe		Recommended Lubrication for STRÖTER All-Steel Variable Speed Gear			
Aufstellung	Die Regelgetriebe sind nur in der Bauform aufzustellen, für die sie erstellt wurden.	Installation	Variable speed gears are only to be installed in the construction design for which they were produced.		
Inbetriebsetzung	Bei der Montage sind Verspannungen der Gehäusefüße oder des Flansches zu vermeiden. Das Aufziehen der Riemenscheiben, Kupplungen usw. erfolgt unter Verwendung der Gewindebohrung im Wellenstumpf. Schläge oder Stöße auf die Wellenstümpfe sind zu vermeiden. Bei axialen Drücken, beispielsweise durch Schnecken- oder Kegelräder verursacht, müssen dieselben durch ein zusätzliches Längslager aufgenommen werden.	Running	During installation, care should be taken to avoid putting undue pressure on the housing feet and the flange. Fitting of the pulleys, couplings etc. is carried out using the thread situated on the shaft end. Knocking or jolting the shaft ends should be avoided. In the event of axial pressures caused, for instance, by worm or bevel gears, these must be taken up by an additional thrust bearing.		
Ölwechsel	Der Regeltrieb kommt betriebsfertig und mit Ölfüllung zum Versand. Es ist besonders darauf zu achten, daß der Öleinfüllstopfen mit einem Entlüftungsloch versehen ist. Andernfalls ist der Öleinfüllstopfen auszuwechseln. Der Ölstand wird im Stillstand kontrolliert, wobei das Ölstandsauge zur Hälfte mit Öl befüllt sein muß. Nach 200 Betriebsstunden ist der erste Ölwechsel vorzunehmen. Weitere Ölwechsel folgen nach jeweils 2000 Betriebsstunden. Als Füllung verwendet man Öle mit mildwirkenden Hochdruckzusätzen und einer Viskosität von ca. 61-75 mm ² /s (cSt) 40° C. Vor der Ölneufüllung ist der Regeltrieb mit Spülöl zu reinigen.	Oil Change	The variable speed gear is dispatched ready for operation and filled with oil. Special care should be taken that the oil filler plug is provided with an air hole. The plug must otherwise be changed. Oil level is checked with the gear inoperative, and the oil level indicator must be filled to the halfway mark. After 200 hours of operation, the first oil change must be carried out. Further oil changes should take place after each 2000 hours of operation. The oils used should contain mild acting high pressure additives and should have a viscosity of about 61-75 mm ² /s (cSt) 40° C. Prior to refilling with fresh oil, the gear is to be cleaned with flushing oil.		
					
AGIP BLASIA 57	BP Energol GR-XP 68 (ISO), BP Energol HLP 68 (ISO).	Chevron Gear Compound 68, Chevron Non-Leaded Gear Compound 68	SPARTAN 68	Mobilgear 626	Meropa 68, Rando Oil HD C
AGIP AG, München		AGIP Companies all over the world			
Deutsche BP AG, Hamburg		BP Companies all over the world			
DEUTSCHE TEXACO VERKAUF GMBH, Hamburg		TEXACO and CALTEX Companies all over the world			
CHEVRON ERDOEL DEUTSCHLAND GMBH, Frankfurt		CHEVRON Companies all over the world			
ESSO AG, Hamburg		ESSO Companies all over the world			
MOBIL OIL A.G. in Deutschland, Hamburg		MOBIL OIL Companies all over the world			



INSTALLATION AND OPERATING MANUAL

BROOKS CONTROL AND READ OUT EQUIPMENT
FOR THERMAL MASS FLOWMETERS
MODELS 5875-5876-5878

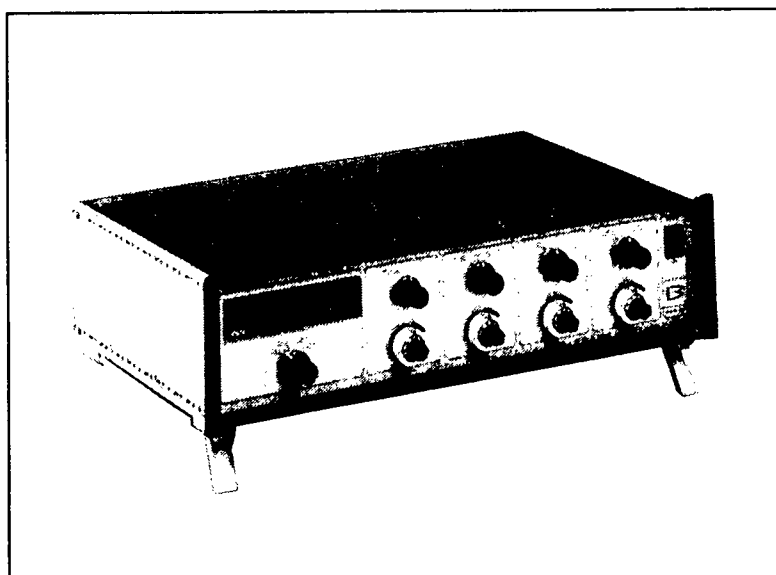

Model 5878

CAUTION: It is recommended that this publication be read in its entirety before performing any operation. Failure to understand and follow these instructions could result in serious personal injury and/or damage to the equipment.

Brooks Instrument B.V.
Groeneveldselaan 6
3903 AZ Veenendaal
P.O. Box 56
3900 AB Veenendaal
The Netherlands
Tel. (0)8385 - 63911
Tlx 37106
Telefax (08385) - 63314

Dear Customer:

This Brooks Instrument Division, Emerson Electric Co., product you have just received is of the highest quality available, offering superior performance to the user. This controller provides the finest degree of accuracy, repeatability, and widest operating parameters available for extremely reliable gas measurement and control of mass flow rate.

Because of the wide variety of applications, we have expressly designed this instrument to provide user selectable functions in a single instrument to meet ever changing process conditions. Additionally, this "state-of-the-art" design has been packaged and materials selected to permit application to a variety of often corrosive and hostile conditions.

To realize the full potential of the inherent design flexibility and ease of maintenance, may we suggest you review this manual in its entirety.

Should you need additional information concerning the 5870 Series Read-out /Controllers, please feel free to contact your local Brooks Instrument Division Sales Office.*

We are pleased to have this opportunity of servicing you for your gas measurement and control needs.

Sincerely,

BROOKS INSTRUMENT DIVISION
Emerson Electric Co.

* The Brooks Instrument Sales Office Addresses you will find on the cover.

WARNING

This instrument contains electronic components that are susceptible to damage by static electricity. Proper handling* procedures must be observed during the removal, installation, or other handling of internal circuit boards or devices.

*** Handling Procedure:**

1. Power to unit must be removed.
2. Personnel must be grounded, via a wrist strap or other safe, suitable means before any printed circuit card or other internal device is installed, removed or adjusted.
3. Printed circuit cards must be transported in a conductive bag or other conductive container. Boards must not be removed from protective enclosure until the immediate time of installation. Removed boards must be placed immediately in protective container for transport, storage, or return to factory.

Comments

This instrument is not unique in its content of ESD (electrostatic discharge) sensitive components. Most modern electronic designs contain components that utilize metal oxide technology (NMOS, CMOS, etc.). Experience has proven that even small amounts of static electricity can damage or destroy these devices. Damaged components, even though they appear to function properly, exhibit early failure.

TABLE OF CONTENTS

	Paragraph no.:	Page no.:
SECTION 1 INTRODUCTION		
General description	1-1	4
Model description	1-2	4
General specification	1-3	4
SECTION 2 INSTALLATION		
Receipt of equipment	2-1	4/5
Return shipment	2-2	5
Recommended storage practice	2-3	5
Housing dimensions	2-4	5
External wiring diagrams	2-5	5
External connection cables	2-6	6
SECTION 3 OPERATION		
Theory of operation model 5875	3-1	6
Blockdiagram model 5875	3-2	6
Theory of operation models 5876, 5878	3-3	7
Blockdiagram model 5878	3-4	7
SECTION 4 PARTS LIST		
Spare parts Model 5875 2-Channel indicator	4-1	8
Spare parts Model 5876 2-Channel blender	4-2	9
Spare parts Model 5878 4-Channel blender	4-3	10
Open frame power supply	4-4	11
3½-Digit L.E.D. Indicator	4-5	11
Interconnecting cables	4-6	12
Interconnecting cables	4-7	12
Interconnecting cables	4-8	12

Section 1 INTRODUCTION

1-1 General Description

The 5870-Series "Control and Read out Equipment", has been designed to power and control Mass Flow Controllers, and to indicate flowrates of Mass Flowmeters.

1-2 Model Description

- For use with Mass Flowsensors, serie: 5810, 5811 and 5812.

Model 5875.
Power Supply and Read Out Unit,
suitable for up to four (4) sensors.

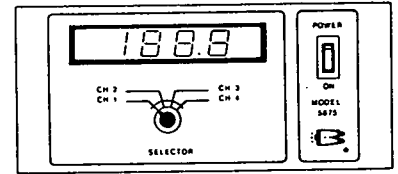

- For use with Mass Flow Controllers, serie: 5850, 5851, 5858 and 5842.

Model 5876.
Dual Channel Power Supply, Read Out
and Control Unit.

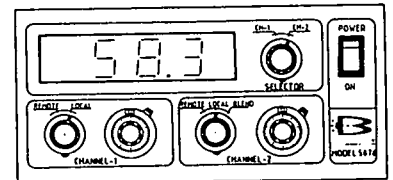

Model 5878.
Four Channel Power Supply, Read Out
and Control Unit.

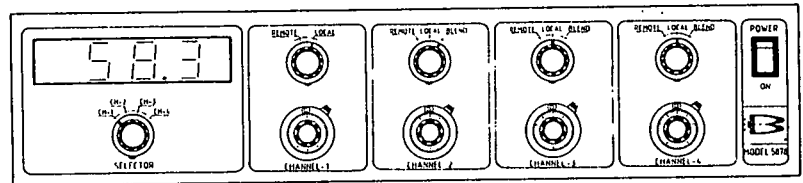

1-3 General Specification

Power input	: 110/220 Volts $\pm 10\%$, 50/60 Hz.
Power output	: + and - 15 Vdc., for max. up to four (4) Mass Flowcontrollers.
Power consumption	: Model 5875, 10W. : Model 5876, 15W. : Model 5878, 25W.
Signal inputs	a. : 0-5 Vdc. flowrate signal from Flowsensor. b. : 0-5 Vdc. setpoint signal, internal resistance signal source: max. 300 ohms.
Signal outputs	a. : 5 Vdc. reference voltage, max. load: 8 mA. b. : 0-5 Vdc. linear to flowrate.
Electrical connections	a. : One off 15-pins "D"-type connector for combined output signals (0-5 Vdc., per channel). Mating connector is included. b. : Two, or four off 15-pins "D"-type connector for connecting the Mass Flowcontrol Meters.
Display	: 3½-digit L.E.D. indicator, Character height: 13 mm. Max. reading: 199,9. Indication is in percentage of flow range.
Controls	: Rotary switch for channel selection of the flowrate indicator. 5 k Ohm ten turn setpoint potentiometers, with locking lever and dial. Power ON/OFF switch. Rotary switch per channel for "BLENDING" ON/OFF and remote/local setpoint
Housing	: Anodized aluminium.
Execution	: Table-top, or panel mounting.
Ambient temperature	: 0-50°C.

Section 2 INSTALLATION

2-1 Receipt of Equipment

When the equipment is received, the outside packing case should be checked for any damage incurred during shipment.

If the packing case is damaged, the local carrier should be notified at once regarding his liability. A report should be submitted to the Product Service Department, Brooks Instrument Division, Emerson Electric Co., Veenendaal, The Netherlands.

Remove the envelope containing the shipping list. Carefully remove the equipment from the packing case. Make sure spare parts are not discarded with the packing material. Inspect for damaged or missing parts.

2-2 Return Shipment

Do not return any assembly or part without a Return Material Report. The Return Material Report is available from all District Sales Offices and the Product Service Department, Veenendaal, The Netherlands. Information describing the problem, corrective action, if any, and the work to be accomplished at the factory must be included.

2-3 Recommended Storage Practice

If intermediate or long term storage is required for equipment, as supplied by Brooks Instrument Division, it is recommended that said equipment be stored in accordance with the following:

1. Within the original shipping container.
2. Stored in a sheltered area, preferably a warm dry heated warehouse.
3. Ambient temperature (21°C. Nominal, 32°C. Max. 7°C. Min.)
4. Relative humidity 45% nominal (60% max., 25% min.)

Upon removal from storage, a visual inspection should be conducted to verify the condition of equipment is "as Received".

2-4 Housing Dimensions

Dimensions:

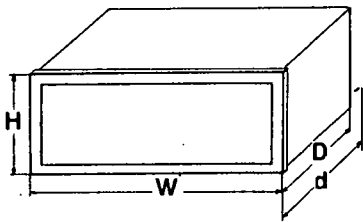

Model	H x W (mm)	D = d-60 (mm)	Panel cut out	
			e (mm)	f (mm)
5875	96 x 192	247	90	186
5876	96 x 192	247	90	186
5878	96 x 384	247	90	378

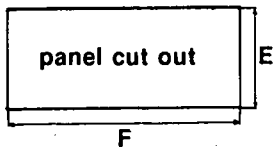

* The 5870 series normally are supplied as table top units. For panelmounting: please remove the stand offs and use the supplied brackets for panel mounting.

2-5 External Wiring Diagrams

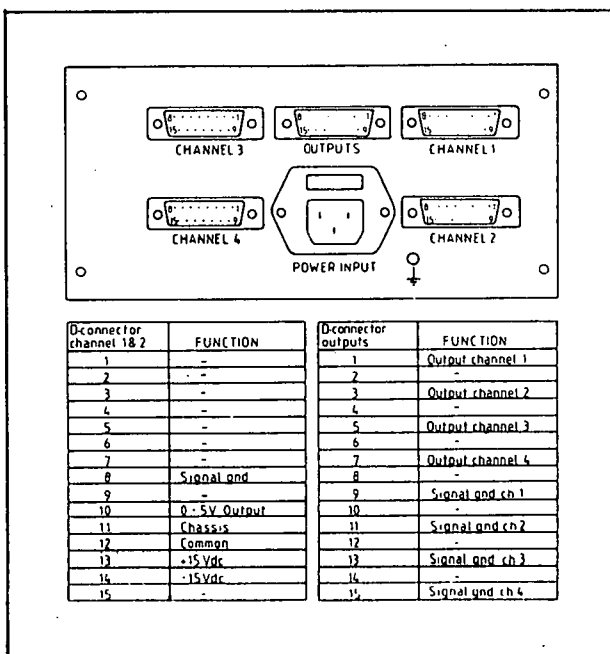

External Connection Diagram for Model 5875

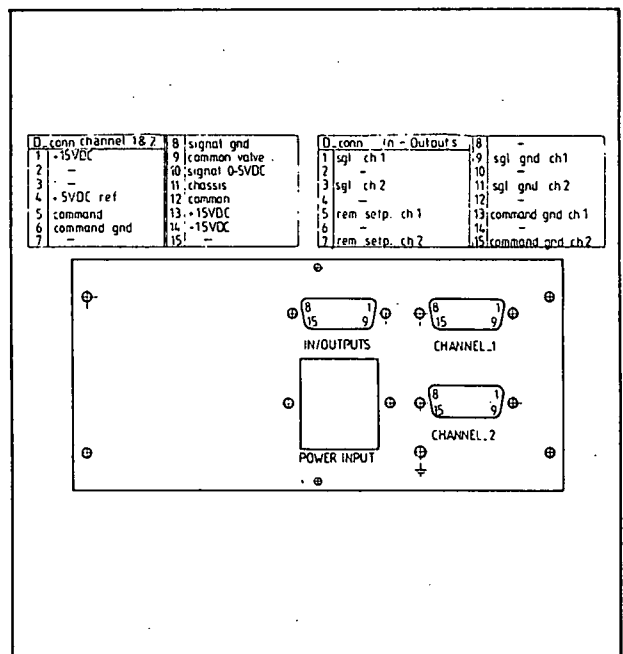

External Connection Diagram for Model 5876

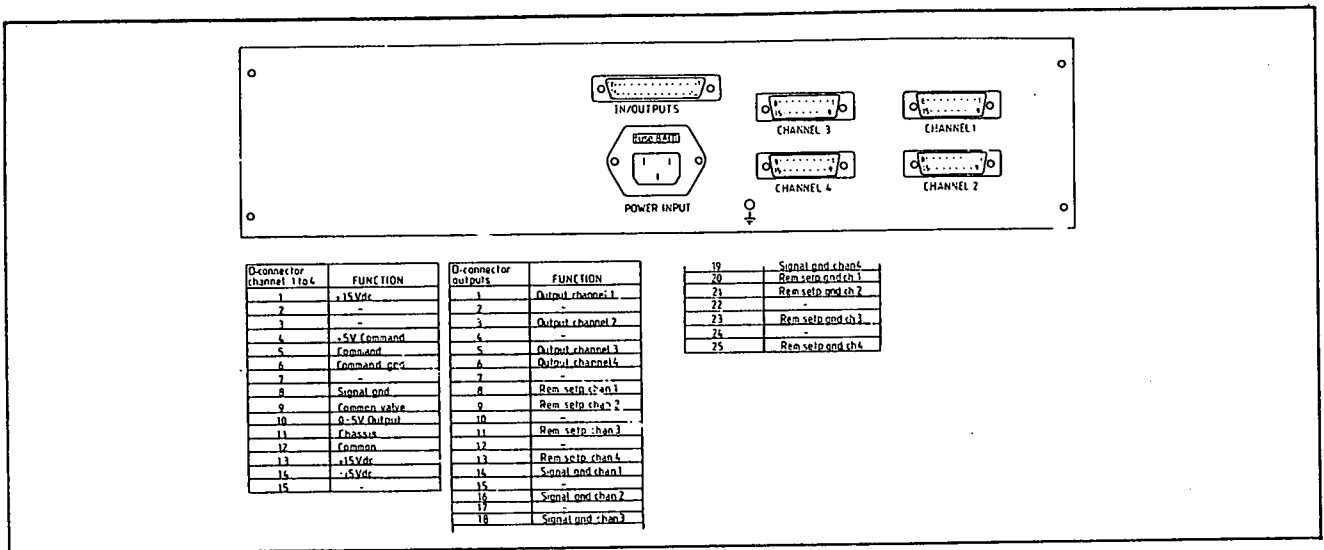

External Connection Diagram for Model 5878

2-6 External connection cables

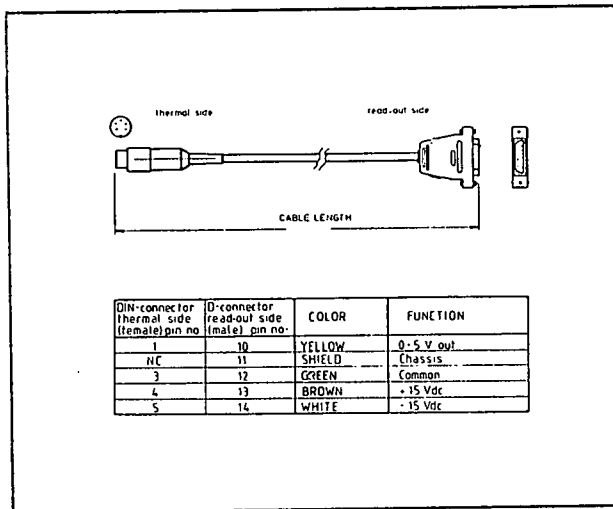

Cable assy with D- and DIN-connector

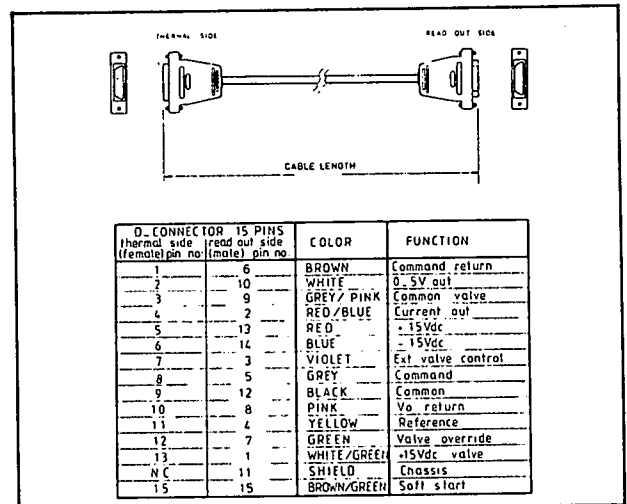

Cable assy with (2x) D-connectors

Section 3 OPERATION

3-1 Theory of operation model 5875

The power Supply Read Out Unit model 5875, has been designed to power Mass Flowsensors and to indicate flowrate.

Flowrate indication has been realised with a 3½-digit L.E.D. display calibrated in percentage of flow.

Channel selection can be determined with a rotary switch.

A socket on the rear panel is available for remote output signals: 0-5 Vdc. linear to flowrate. Max. load 2 mA.

3-2 Block diagram Model 5875

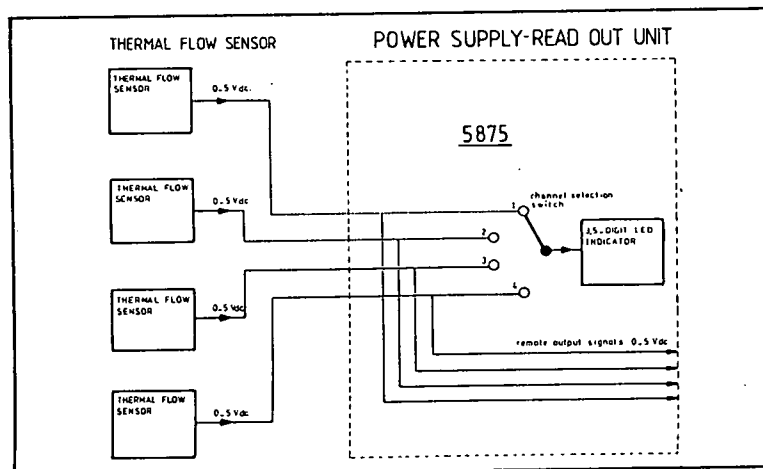

3-3 Theory of operation Models 5876 and 5878

The Dual and Four Channel Power Supply, Read Out and Control Unit, models 5876 and 5878 have been designed to power Mass Flow Controllers.

Flowrate is indicated by a 3½-digit L.E.D. display, calibrated in percentage of flow.

Channel selection can be determined with a rotary switch.

The setpoint signals for the Mass Flow Controllers can be switched to three different references by means of frontpanel mounted rotary switches.

The three possibilities are:

1. Local:

The setpoints can be adjusted with the potentiometers in the frontpanel.

2. Remote

The setpoint signals of a remote reference are used.

The setpoint potentiometers are not in use.

3. Blending

Channel one is the master channel and can be switched to local or remote setpoint. The other channels can be switched to the "blend" mode.

In this mode the flowrate signal of channel one is used as a reference voltage for the setpoint potentiometers of the slave channels.

The dial shows the percentage of the rate of flow of the belonging slave channel, when the master flowrate is 100%.

3-4 Block diagram model 5878

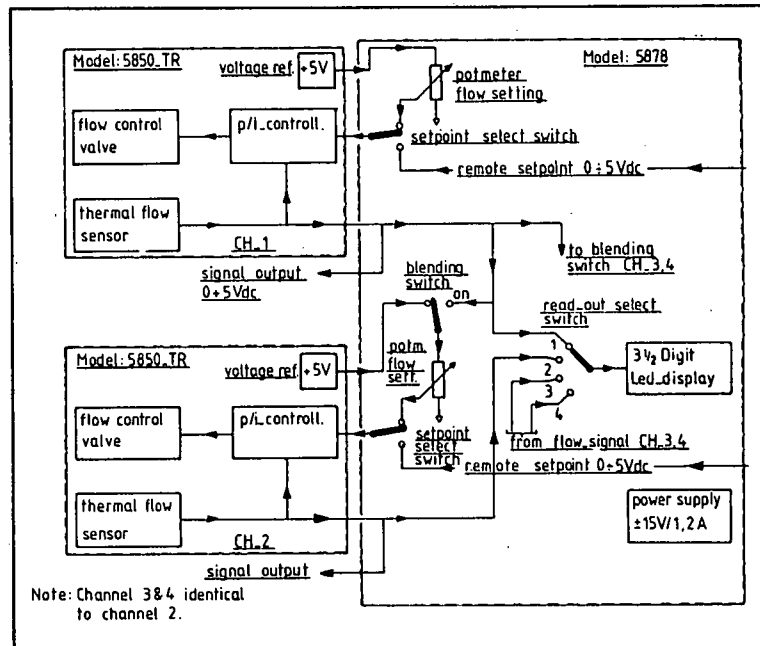

4-2 Spare parts Model 5876 2-Channel Blender

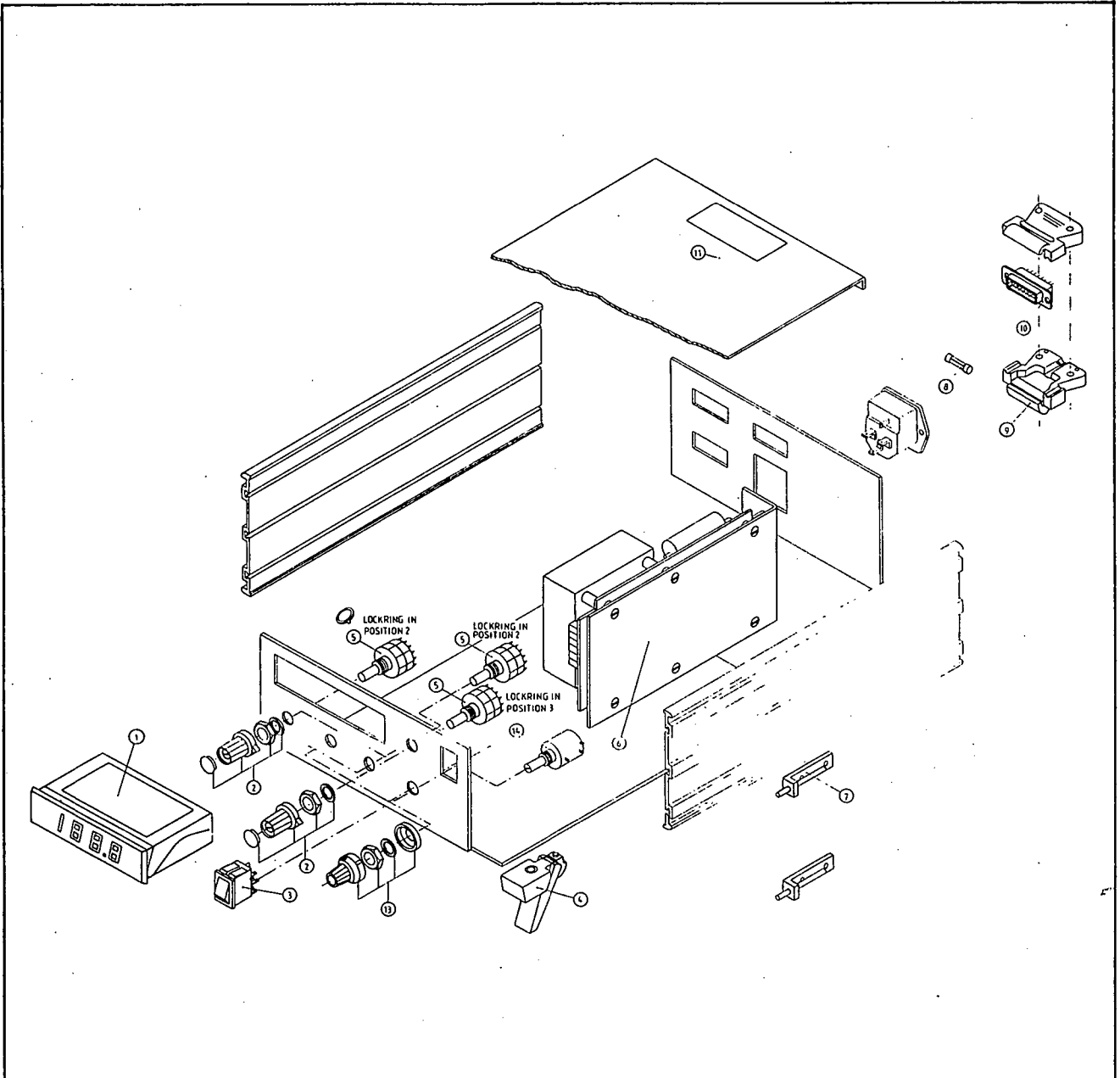

Ref. Nr.	Partnumber	Description	Remarks	Qty. used
1	549-V-003-HVK	Digital panel meter		1
2	*498-C-081-PLQ	Knob with cap		3
3	*859-E-008-PZZ	Tumbler switch, DPDT		1
4	594-B-041-AAA	Pedestal		2
5	860-F-001-PTP	Rotary switch, 3 position	setpoint selector	2
5	860-P-002-PTP	Rotary switch, 2 position	Indicator selector	1
6	641-D-029-ETB	Power supply unit		1
7	*852-Z-171-EAA	Mounting bracket		2
8	*365-Z-031-PDZ	Fuse 630 mA	For 115 Vac supply	2
8	*365-Z-030-PCZ	Fuse 315 mA	For 220 Vac supply	2
9	206-Z-069-AAA	Connector hood		1
10	206-E-007-AAA	D-connector: 15 pin. male		1
11	613-Z-326-EAD	Top plate 247 x 177 mm.		1
13	*233-Z-179-ZZZ	Dial potmeter 10-turn		2
14	*635-D-020-GJE	Potmeter 10-turn, 5K-Ohms		2

4-4 Open frame power supply, suitable for up to four (4) Mass Flow Controllers

- 110 Vac power supply : connect to pin 1 and 6 to power 110 Vac, connect pin 2 to 4 and pin 3 to 5.
- 220 Vac power supply : connect to pin 1 and 6 to power 220 Vac, connect pin 3 to 4.
- Power input : 110/220 Volts \pm 10%, 50/60 Hz.
- Power output : + and - 15 V.d.c., 1,2 Amp.
Max. power: 18,0 Watts
- Dimensions : 68 x 160 x 82 mm. (HxWxD)
- Part number : 641-D-029-ETB

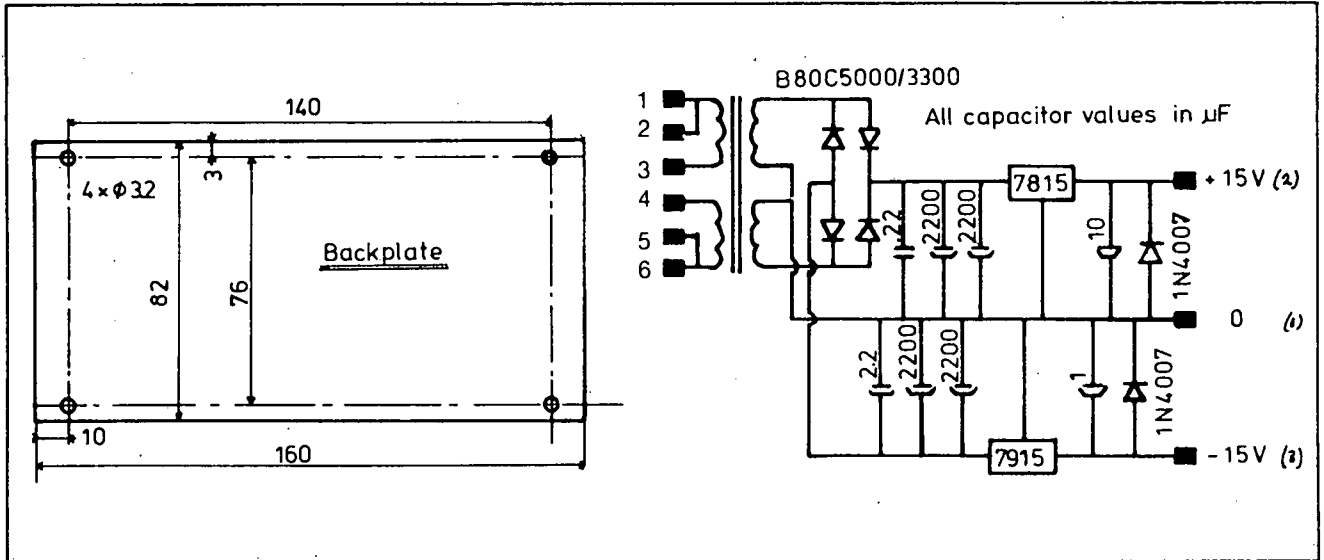

4-5 3½-digit L.E.D. Indicator

- Max. reading : 199,9
- Character height : 13 mm.
- Power requirements : + 15 Vdc., 100 mA
- Signal input : 0-5 Vdc.
- Dimensions : 25 x 96 x 68 mm. (HxWxD)
- Panel cut-out : 22 x 92 mm.
- Part number : 549-V-003-HVK

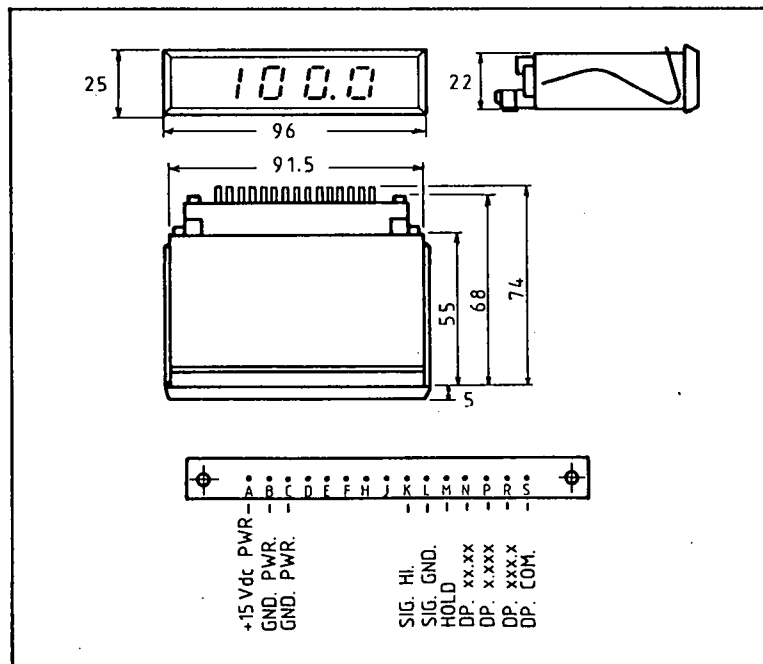

4-6a Interconnecting cable complete with plugs, for connecting 5875-Series:

Power supply and Read-Out Unit to the series: 5810, 5811 and 5812 Mass Flowmeters.
LENGTH: 3 meter. PART NUMBER: 124-Z-233-AAA

4-6b Interconnecting cable:

LENGTH: 6 meter. PART NUMBER: 124-Z-234-AAA

4-7a Interconnecting cable complete with plugs, for connecting 5876/5878 serie:

Power supply, Read-Out and Control Unit to the series 5850, Mass Flow Controllers.
LENGTH: 3 meter.
PART NUMBER: 124-Z-236-AAA

4-7b Interconnecting cable:

LENGTH: 6 meter
PART NUMBER: 124-Z-237-AAA

4-8a Interconnecting cable complete with plugs, for connecting 5876/5878 serie:

Power supply, Read-Out and Control unit to the series 5851, Mass Flow Controllers:
LENGTH: 3 meter
PART NUMBER: 124-Z-380-AAA

4-8b Interconnecting cable:

LENGTH: 6 meter
PART NUMBER: 124-Z-381-AAA

Guarantees

If at any time within one year after shipment, but not thereafter, it is proved that any part of the equipment furnished by us was defective when shipped by us, we will repair or replace the same free of charge, F.O.B. our plant. Notice of this claim must be made to us within one year after delivery. Our liability is limited to replacement of such defective parts or equipment. There are no guarantees or warranties expressed or implied other than those herein specifically mentioned.

Brooks Instrument Division shall not in any event be liable for any consequential damages, secondary charges, expenses for erection or disconnection, or losses resulting from any alleged defect in the apparatus. It is understood that corrosion or erosion of materials is not covered by our guarantee.

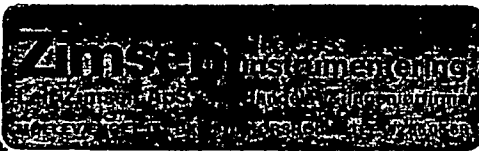

Brooks Instrument B.V.
P.O. Box 56
3900 AB Veenendaal
The Netherlands

CALIBRATION CERTIFICATE THERMAL MASS FLOWMETER

Cust. : Leif Zimser APS
Tag.no. : -
P.O. no. : 90070605

Our ref. S.N. : M24,630
Model no. : 5850TR /C1A1C6D10
S.N. Electronics : M24,630 Channel: 1

Customer Conditions	Calibration Conditions
Fluid : <u>Air</u>	Fluid : <u>Air</u>
Temp. : t = <u>20</u> °C	Cal.press. : P1 a = <u>6</u> bar
Upstr.press. : P1 c = <u>6</u> bar	Cal.press. : P2 a = <u>5</u> bar
Downstr. press. : P2 c = <u>5</u> bar	Bar.press. : P = <u>1023,7 + 11,2</u> m bar
Range : <u>0 - 1 Pa /min</u>	Temp. : t = <u>21,4</u> °C
	Corr. factor : K = <u>0,9407</u>
	Normal (n) K = $\frac{P}{1013,33} \times \frac{273,15}{(273,15 + t)}$
	Standard (st) K = $\frac{P}{1013,33} \times \frac{293,15}{(273,15 + t)}$

Ind. reading Volt dc	Desired flow gas	Actual flow gas	Error % of max.
5,00	<u>1,00 Pa /min Air</u>	<u>1,001 Pa /min Air</u>	<u>+0,13</u>
3,75	<u>0,75 Pa /min Air</u>	<u>0,748 Pa /min Air</u>	<u>-0,18</u>
2,50	<u>0,50 Pa /min Air</u>	<u>0,499 Pa /min Air</u>	<u>-0,06</u>
1,25	<u>0,25 Pa /min Air</u>	<u>0,251 Pa /min Air</u>	<u>+0,11</u>
0,50	<u>0,10 Pa /min Air</u>	<u>0,099 Pa /min Air</u>	<u>-0,09</u>

Remarks:

Gas conversion factor: -
Air x - = -

Restrictor size : 10 μ
Orifice size : 0,014 inch
Valve seat mat'l : Nylon
O-ring mat'l : Nylon
Max. press. : 100 bar
Helium leak test : 1x10⁻⁶ m bar.l.s.⁻¹

Tel no: 07004 / 02
OEM FILE NR: D100

Date : 21-04-90
Calibrator : Leif
Certified by : Leif



INSTALLATION AND OPERATING MANUAL

BROOKS MASS FLOW METER / CONTROLLER MODEL 5850TR

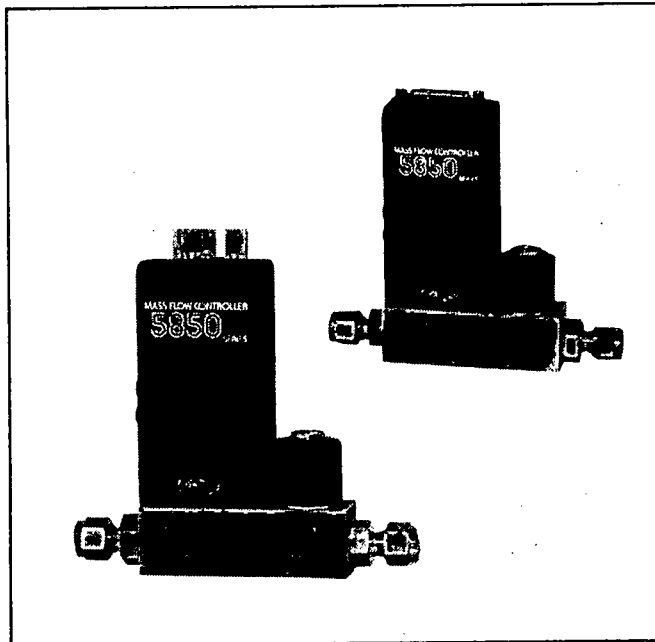

Model 5850TR

CAUTION:

It is recommended that this publication be read in its entirety before performing any operation. Failure to understand and follow these instructions could result in serious personal injury and/or damage to the equipment.

Brooks Instrument B.V.
Groeneveldselaan 6
3903 AZ Veenendaal
P.O. Box 56
3900 AB Veenendaal
The Netherlands
Tel (0)8385 - 63911
Telex 37106
Fax (0)8385 - 63314

Dear Customer,

The Brooks Instrument Mass Flow Controller you have just received is of the highest quality available, offering superior performance to the user. This controller provides the finest degree of accuracy, repeatability, and widest operating parameters available for extremely reliable gas measurement and control of mass flow rate.

Because of the wide variety of applications for mass flow controllers, we have expressly designed this instrument to provide user selectable functions in a single instrument to meet ever changing process conditions. Additionally, this "state-of-the-art" design has been packaged and materials selected to permit application to a variety of often corrosive and hostile conditions.

To realize the full potential of the inherent design flexibility and ease of maintenance, may we suggest you review this manual in its entirety.

Should you need additional information concerning the 5850 Series Mass Flow Controllers, please feel free to contact your local Brooks Instrument Division Sales Office.*

We are pleased to have this opportunity of servicing you for your gas measurement and control needs.

Sincerely,

BROOKS INSTRUMENT DIVISION
OF THE ROSEMOUNT MEASUREMENT
AND CONTROL GROUP.

* The addresses you will find on the cover.

CAUTION

This instrument contains electronic components that are susceptible to damage by static electricity. Proper handling* procedures must be observed during the removal, installation, or other handling of internal circuit boards or devices.

* **Handling procedure:**

1. Power to unit must be removed.
2. Personnel must be grounded, via a wrist strap or other safe, suitable means before any printed circuit card or other internal device is installed, removed or adjusted.
3. Printed circuit cards must be transported in a conductive bag or other conductive container. Boards must not be removed from protective enclosure until the immediate time of installation. Removed boards must be placed immediately in protective container for transport, storage, or return to factory.

COMMENTS

This instrument is not unique in its content of ESD (electrostatic discharge) sensitive components. Most modern electronic designs contain components that utilize metal oxide technology (NMOS, CMOS, etc.). Experience has proven that even small amounts of static electricity can damage or destroy these devices. Damaged components, even though they appear to function properly, exhibit early failure.

TABLE OF CONTENTS

	Paragraph number	Page number
Section 1 INTRODUCTION		
Purpose	1-1	4
Description	1-2	4
Standard user selectable features	1-2-1	4
Optional features	1-2-2	4
Receipt of equipment	1-3	4
Return shipment	1-4	5
Recommended storage practice	1-5	5
Specifications	1-6	5/6
Standard manufacturing procedures	1-7	7
Section 2 INSTALLATION		
Gas connections	2-1	7
In-line filter	2-2	7
Installation	2-3	7
Electrical connection	2-4	8
Setpoint	2-4-1	8
Soft Start	2-4-2	8
Remote programming	2-4-3	8
Valve override	2-4-4	8
External valve control	2-4-5	8
Current output	2-4-6	8
Section 3 OPERATION		
Theory of operation	3-1	11
Operation procedure	3-2	11
Zero Adjustment	3-3	13
Calibration procedure	3-4	13/14
Sizing of the control valve	3-5	14
Kv-values and max. acceptable pressure drop over the valve	3-5-1	14
Section 4 MAINTENANCE		
General	4-1	15
Control valve	4-2	15
Trouble shooting	4-3	15
Use of the gas conversion table	4-4	16
Section 5 SPARE PARTS		
Recommended spare parts 5850-TR with N.C. valve, 100 Bar	5-1	20/21
Recommended spare parts 5850-TR with N.O. valve, 100 Bar	5-1-1	21
Recommended spare parts 5850-TR with N.C. valve, 300 Bar	5-1-2	22
Service Tools	5-1-3	22
LIST OF ILLUSTRATIONS		
Control valve types	1-1	4
Dimensions	2-1	6
5850-TR Card Edge Hook-up diagrams	2-2	9
5850-TR Card Edge Connections diagram	2-3	9
5850-TR "D" hook-up diagrams	2-4	10
5850-TR "D" connections diagram	2-5	10
Flow Sensor operational diagram	3-1	11
Control System blockdiagram	3-2	11
Printed Circuit Board Assy	3-3	11
Schematic Diagram Card Edge	3-4	12
Schematic Diagram "D" connection	3-5	12
Typical calibration installation	3-6	13
Exploded View 5850-TR	5-1	19
TABLE		
Conversion factors	4-4-1	17/18

Section 1 INTRODUCTION

1-1 Purpose

The Brooks Model 5850TR Mass Flowmeter / Mass Flow Controller is a mass flow measuring device, designed for accurately measuring and rapidly controlling flows of gases.

1-2 Description

The Brooks Model 5850TR Mass Flow Controller (M.F.C.) provides "state-of-the-art" mass flow measurement and P.I. control.

The Brooks Model 5850TR M.F.C. is used widely in the Semiconductor Industry as well as many others, where manual, electronic or computer controlled gas handling occurs.

The Model 5850TR consists of three basic units: a flow sensor, a control valve and an integrated electronic control system.

This combination produces a stable gasflow, selectable overshoot protection and eliminates the need for continuous monitoring and re-adjustment of gas pressures.

1-2-1 Standard user selectable features includes:

- **Soft start** provides a flow ramping function that effectively reduces gas flow over-/undershoot to a neglectable value.
Refer to Section 2-4-2.
- **Remote programming** permits the user to program the Mass Flow Controller with an external 0-5Vdc, or 0-10Vdc command voltage in lieu of the command potentiometer.
Refer to Section 2-4-3.
- **Valve override** permits the user to fully open and close the control valve independent of the command setting.
Refer to Section 2-4-4.
- **External valve control** permits the user flexibility to provide an external valve control source independent of the standard control incorporated within this Mass Flow Controller.
Refer to Section 2-4-5.

The 5850TR M.F.C. can be supplied with three different type control valves:

- Normally Opened, max. 100 Bar operating pressure.
- Normally Closed, max. 100 Bar operating pressure (std).
- Normally Closed, max. 300 Bar operating pressure.

1-2-2 Optional features

The Mass Flow Controller in combination with the integral Indicator/Controller, Model 5879 can easily be used for local Read-Out and Control adjustment.

The 5879 is supplied with a power supply adapter and interconnecting cable.

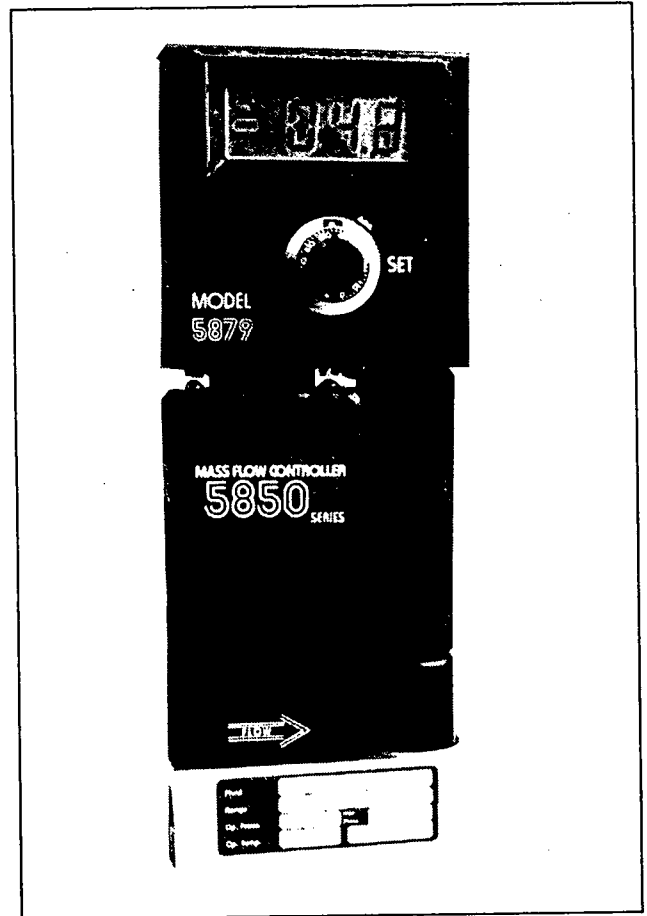

Model 5850 / 79

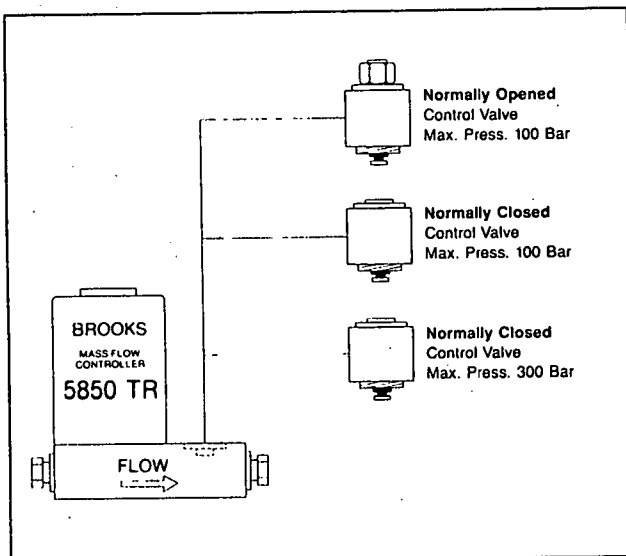

Figure 1-1 Control Valve types

1-3 Receipt of equipment

When the equipment is received, the outside packing case should be checked for any damage incurred during shipment.

If the packing case is damaged, the local carrier should be notified at once regarding his liability.

A report should be submitted to the Product Service Department, Brooks Instrument / Rosemount. Refer to the cover for full address.

Remove the envelope containing the shipping list. Carefully remove the equipment from the packing case. Make sure spare parts are not discarded with the packing material.

1-4 Return Shipment

Do not return any assembly or part without a Return Material Report. The Return Material Report is available from all District Sales Offices and the Product Service Department.

Information describing the problem, corrective action, if any, and the work to be accomplished at the factory must be included.

1. Within the original shipping container.
2. Stored in a sheltered area, preferably a warm, dry, heated warehouse.
3. Ambient temperature (21°C Nominal, 32°C max. / 7°C min.)
4. Relative humidity 45% Nominal (60% max., 25% min.)

1-5 Recommended Storage Practice

If intermediate or long term storage is required for equipment, as supplied by Brooks Instrument Division, it is recommended that said equipment be stored in accordance with the following:

Upon removal from storage, a visual inspection should be conducted to verify the condition of equipment is "as received".

If the equipment has been in storage for an excess of ten (10) months or in conditions in excess of those recommended, all pressure boundary seals should be replaced and the device subjected to a pneumatic pressure in accordance with the applicable vessel codes.

1-6 Specifications

Standard ranges in ml _n /min Normal is defined as: milliliter at 0°C (273K) and 1,013 Bar Abs	Any full scale range between 5 ml _n /min and 20.000 ml _n /min (Nitrogen equivalent)
Rangeability	50 to 1
Accuracy, including Linearity	± 1,0% full scale at calibrated conditions.
Repeatability	± 0,2% full scale
Attitude insensitivity	The M.F.C. can be mounted in "any" position with maximum deviation in specified accuracy of 0,25% full scale.
Pressure sensitivity	± 0,1% full scale/Bar
Temperature sensitivity	± 0,1% /°C of full scale in temperature range: 0 - 65 °C
Operating and ambient temperature range	0 - 65 °C
Max. operating pressure	100 Bar in combination with the normally opened or normally closed valve. 300 Bar in combination with the normally closed high pressure valve or as sensor only.
Leak integrity, inboard-outboard	1 x 10 ⁻⁶ mBar l/s of Helium (except for PTFE sealing)
Warming-up time	45 minutes

Power requirements MASS FLOW METER	+15 Vdc, $\pm 5\%$, +25 mA max. max. ripple 7 mV p-p -15 Vdc, $\pm 5\%$, -15 mA max. max. ripple 7 mV p-p	
Required Power Supply MASS FLOW CONTROLLER	When supplied with negative valve voltage +15Vdc, $\pm 5\%$, +25mA max max. ripple 7 mV p-p -15Vdc, $\pm 5\%$, 180mA max. max. ripple: 7 mV p-p	When supplied with positive valve voltage +15Vdc, $\pm 5\%$, +180mA max. max. ripple, 7 mV p-p -15Vdc, $\pm 5\%$, -15mA max. max. ripple 7 mV p-p
Output Signal	0-5 Vdc min. load: 1 K-ohm max. ripple: 3 mV	Optional: 0-10 Vdc min. load: 4 K-ohm max. ripple: 6 mV Or: 0-20 mA max. 400 ohm floating load
Remote Programming	External voltage: 5 Vdc Load resistance: min. 1 K-ohm Load resistance: max. 5 K-ohm	or 0-10 Vdc min. 4 K-ohm max. 5 K-ohm
Electrical connections	Card Edge - 20 pins, or "D" connector - 15 pins	
Materials of Construction	Wetted parts stainless steel with Viton [®] , PTFE, Buna-N [®] or Kalrez [®]	
Gas Connections	9/16" - 18 UNF	
Gas fittings (The inlet gas fitting is supplied with an inletfilter)	6 mm. Tube Compression 1/4" Tube Compression 1/4" VCO 1/4" VCR 1/4" NPT 1/8" Tube Compression 3/8" Tube Compression	

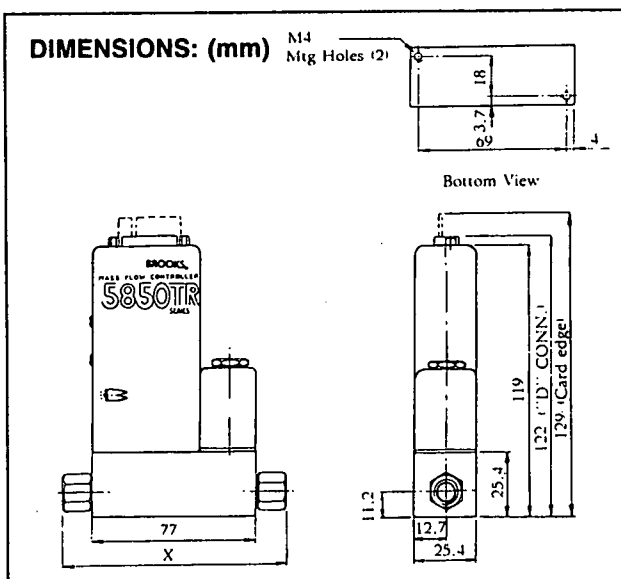

Figure 2-1 Model 5850TR Dimensions

Connections	Dim.X
9/16" - 18 UNF	77
1/4" Tube Compression	129
1/8" Tube Compression	124
1/4" VCR	125
1/4" VCO	117
1/4" NPT	118
6 mm. Tube Compression	129

Note: Dimensions are in mm.

1-7 Standard Manufacturing Procedures

Brooks Instrument warrants the supply of very high quality Flow measurement and control equipment. Upon receipt of incoming materials, till shipment of instruments, fabrication of the BROOKS MASS FLOW CONTROLLERS are monitored at every production stage.

Assembly, The Mass Flow Controllers are assembled in our cleanroom.

E.S.D. Handling, the printed circuit boards are assembled by qualified personnel, who are protected against Electro Static Discharge.

Pressure test, each Mass Flow Controller is pressure tested at 1,5 times the maximum working pressure.

Burn-in test, each instrument undergoes a temperature burn-in test for 48 hours. In this time the instruments are continuously tested under severe conditions.

Calibration, in our calibration department the instruments are calibrated in accordance with the customers requirements.

Brooks Instrument uses their patented VOL-U-METER, and BELL PROVER calibration equipment, which are used as a **primary standard**, certified by the National Bureau of Standards.

Helium leak-test, when the Mass Flow Controllers have been calibrated, the instruments are subject to a leak test, using a Helium Leak Detector.

Sensitivity: 1×10^{-11} ml/sec. He.

For model 5850TR, Brooks warrants an inboard-outboard leak integrity: 1×10^{-6} m.bar. l/sec. of Helium.

Final inspection, The instruments are visually inspected, identified for serial control and completed with a calibration certificate.

E.S.D. package, each Mass Flow Controller is carefully packed in a specially designed Electro Static Discharge box, provided with a sticker for serial control.

Section 2 INSTALLATION

2-1 Gas Connections

Standard inlet and outlet connections supplied with Model 5850TR are 1/4" tube compression fittings, for flowrates up to 10 l_n/min. and 3/8" tube compression fittings for higher flowrates, 6 mm tube compression fittings, 1/4"-VCO, 1/4"-VCR, 1/4"-NPT, or 1/8" tube compression fittings are available upon request.

Prior to installation, make certain all piping is clean and free of obstruction. Install the piping in such a manner that permits easy removal if the instrument has to be removed for cleaning, or bench troubleshooting.

2-2 In-line Filter

It is recommended an in-line filter be installed upstream and sometimes downstream from the flowsensor to prevent the possibility of any foreign material entering the Mass Flow Sensor or Controller.

The filter element should be periodically replaced or

may be ultrasonically cleaned.

Refer to table: 2-2

Maximum Flow Rate	Recommended Filter Size
100 ml _n /min.	1 micron
500 ml _n /min.	2 micron
1 or 5 l _n /min.	7 micron
10 or 20 l _n /min.	15 micron

Table 2-2 Recommended Filter Size

2-3 Installation

CAUTION: When installing the controller, care should be taken that no foreign materials enter the inlet or outlet off the instrument. Do not remove the protective end caps until time of installation.

Recommended installation procedures:

- The Model 5850TR should be located in a clean dry atmosphere relatively free from shock and vibration.
- Leave sufficient room for access to the electrical components.
- Install in such a manner that permits easy removal if the instrument requires cleaning.

CAUTION: When used with a reactive (sometimes toxic) gas, contamination or corrosion may occur as a result of plumbing leaks or improper purging. Plumbing should be checked carefully for leaks and the controller purged with dry Nitrogen before use.

- The Model 5850TR Mass Flow Controller can be installed in any position. However, mounting orientations other than the original factory calibration (see data sheet) will result in a $\pm 0,25\%$ maximum full scale shift.
- When installing controllers with full scale flow rates of 10 l_n/min or higher; be aware that sharp abrupt angles in the system piping directly upstream of the controller may cause a small shift in accuracy. If possible have at least 10 pipe diameters of straight tubing upstream of the 5850TR Mass Flow Controller.

NOTE: The control valve in the Model 5850TR provides precision control and is not designed for positive shut off. If positive shut off is required, it is recommended that a separate shut-off valve be installed in-line.

CAUTION: Since the Model 5850TR control valve is not a positive shut-off, a separate solenoid valve may have been installed for that purpose. It should be noted that a small amount of gas may be trapped between the downstream side of the mass flow controller and the solenoid resulting in a surge upon actuation of the controller. This surge can be reduced in magnitude by locating the controller and solenoid valve close together or by moving the solenoid valve upstream of the controller.

2-4 Electrical Connection (Refer to figure 2-2 to 2-5)

The 5850TR can be supplied with a Card Edge connector suitable for flat cable connections, or with a 15-pins "D"-connector suitable for round cable connections.

2-4-1 Setpoint

The command potentiometer (if used) may be furnished with the instrument or may be supplied by the user. The potentiometer should be a 1 K-ohm or 5 K-ohm 10-turn precision potentiometer with 0,25% linearity. (Beckman 7240 Series or equivalent.)

Card Edge connections: refer to figure 2-2 and 2-3.
 "D" connections : refer to figure 2-4 and 2-5.

2-4-2 Soft Start (standard option, for controller only)

To enable Soft-Start:

Card Edge connect pin E (black wire) to pin C (blue wire)

"D"-connector connect pin 15 to pin 3 or 9

To disable Soft-Start:

Card Edge disconnect pin E (black wire) from pin C (blue wire)

"D"-connector disconnect pin 15 from pin 3 or 9

2-4-3 Remote Programming

If the controller is to be programmed for an external 0-5 Vdc command voltage, the command potentiometer is not used.

The external command voltage (+) is applied to the command signal and (-) to the command signal return.

Card Edge refer to figure 2-3
 command signal to pin A.
 command signal return to pin B.

"D"-connector refer to figure 2-5
 command signal to pin 8
 command signal return to pin 1.

2-4-4 Valve Override

It is possible to drive the control valve fully open or close, independent of the controller position.

Control valve normally closed	Opened	Closed
Card Edge p.v.v., pin 9 Card Edge n.v.v., pin 9	+15 Vdc -15 Vdc	-15 Vdc +15 Vdc
Sub "D" p.v.v., pin 12 Sub "D" n.v.v., pin 12	+15 Vdc -15 Vdc	-15 Vdc +15 Vdc

Control valve normally opened	Opened	Closed
Card Edge p.v.v., pin 9 Card Edge n.v.v., pin 9	-15 Vdc +15 Vdc	+15 Vdc -15 Vdc
Sub "D" p.v.v., pin 12 Sub "D" n.v.v., pin 12	-15 Vdc +15 Vdc	+15 Vdc -15 Vdc

2-4-5 External Valve Control

It is possible to drive the valve with an external P.I. controller. This can be enabled by removing Jumper J2 a-b and inserting Jumper J2 a-c.

2-4-6 Current output (only available at Card Edge connection, N.C. valve).

The 5850TR is provided with a current output of 0 to 20 mA into floating load.

The "+" of the indicator must be tied to pin 4 (violet wire).

The "-" of the indicator must be tied to pin K (grey wire).

If an external voltage source of +24 Vdc is available the current output can be used as follows: the "+" of the indicator must be tied to the +24 Vdc whilst the pin K (grey wire) must be tied to the "-" input of the indicator. Also the minus of the 24 Vdc must be connected to pin C (blue wire).

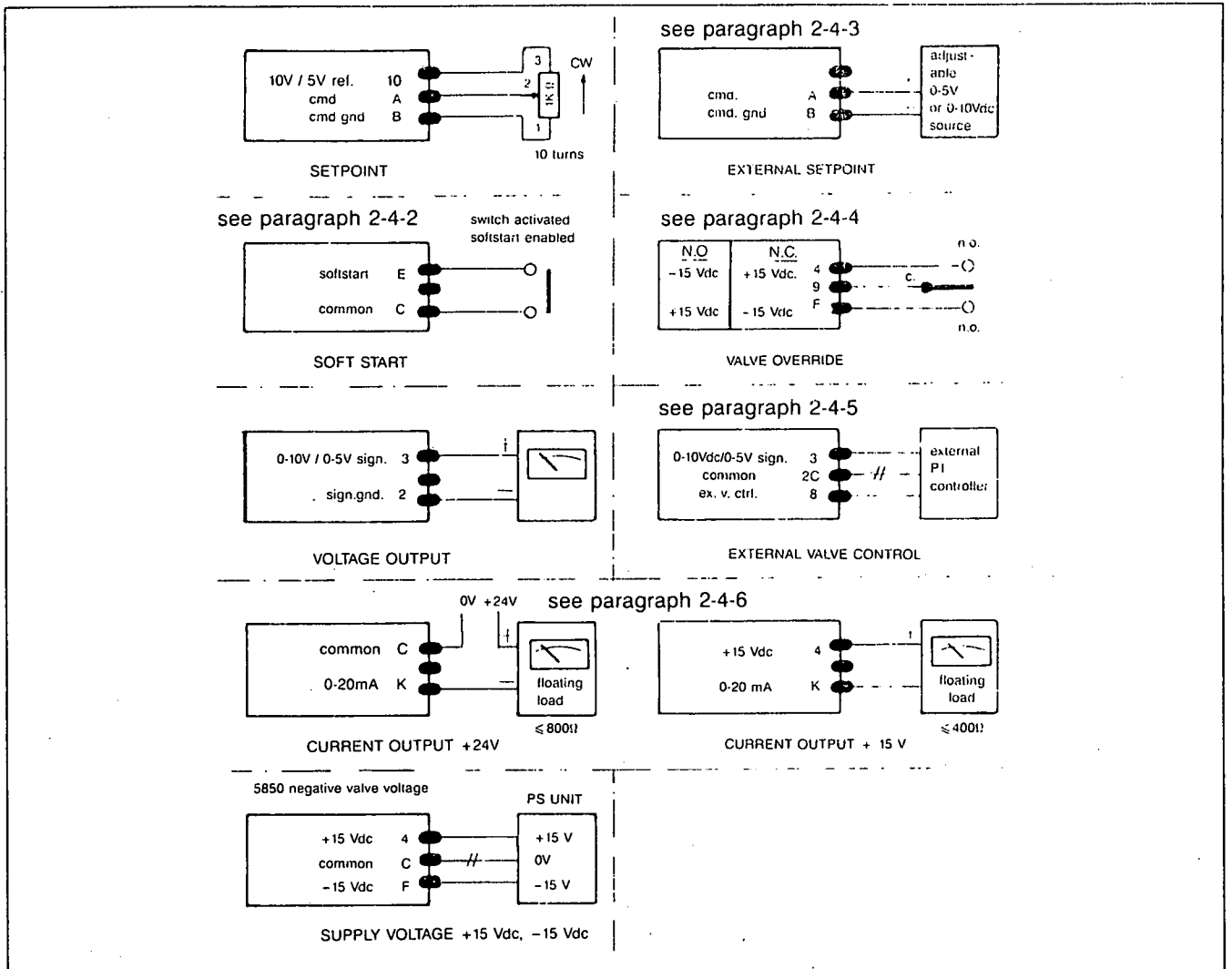

Figure 2-2
5850TR Hook-up Diagrams
Card Edge

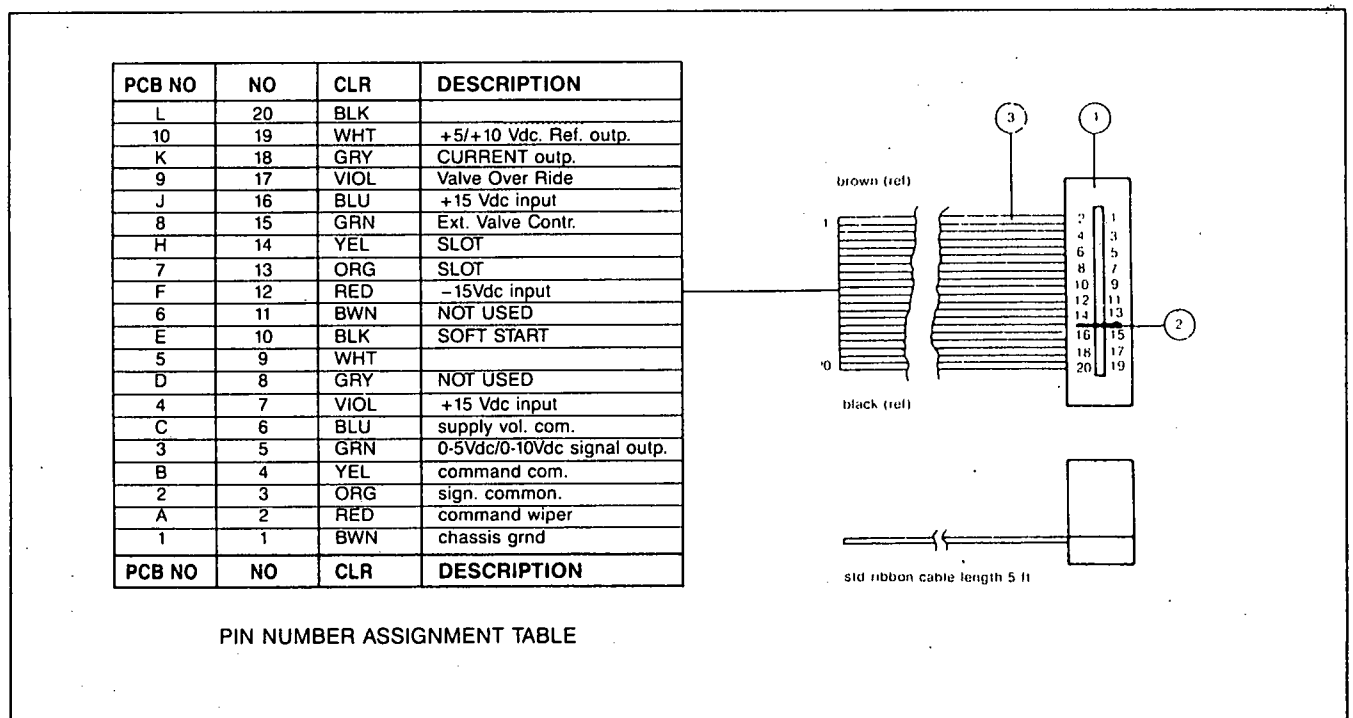

Figure 2-3
5850TR Connections Diagram Card Edge

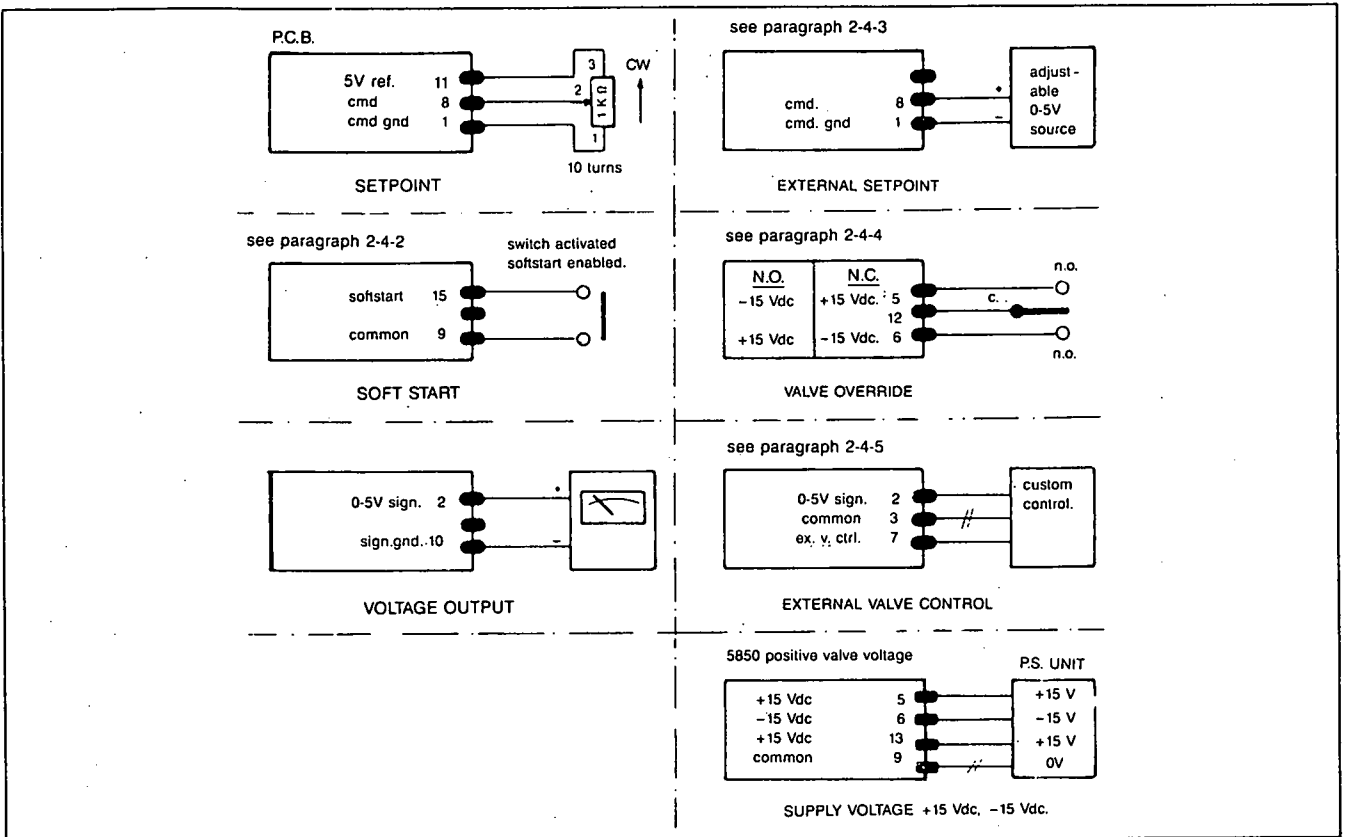

Figure 2-4
5850TR Hook-up Diagrams
15 pins sub "D"-connector

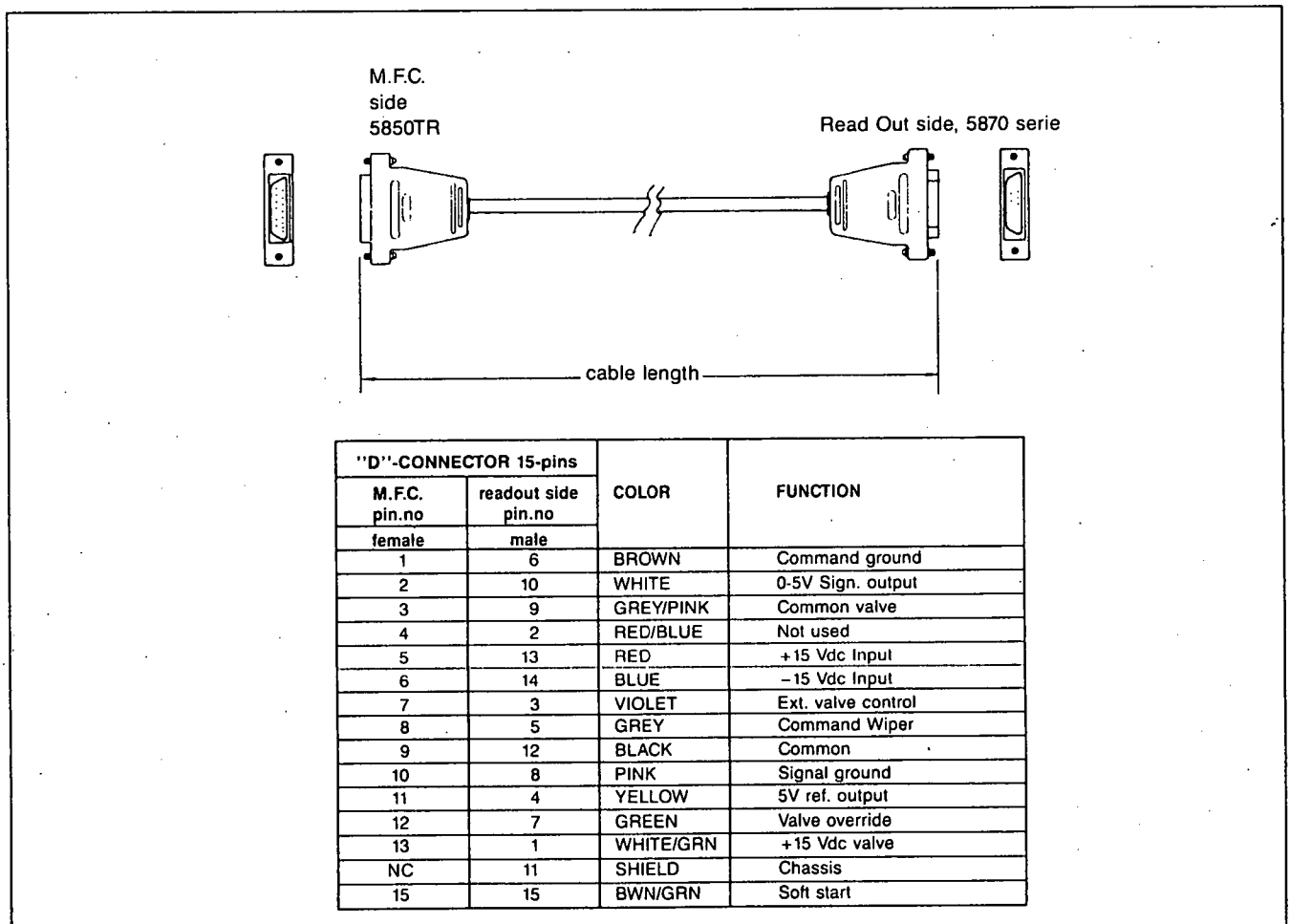

Figure 2-5
5850TR Connections Diagram "D"-Connector

Section 3 OPERATION

3.1 Theory of Operation

The thermal mass flow sensing technique used in the 5850TR works as follows:

A precision power supply provides a constant power heat input (P) at the heater, which is located at the midpoint of the sensor tube. Refer to Figure 3-1. At zero, or no flow conditions the heat reaching each temperature sensor is equal. Therefore the temperatures T1 and T2 are equal. When gas flows through the tube the upstream sensor is cooled and the downstream sensor is heated, producing a temperature difference. The temperature difference T2-T1, is directly proportional to the gas mass flow.

The equation is: $\Delta T = A * P * Cp * m$

Where:

ΔT = Temperature difference T2-T1 (K)

Cp = Specific heat of the gas at constant pressure (kJ.kg⁻¹.K⁻¹)

P = Heater power (kJ/s)

m = Mass Flow (kg/s)

A = Constant of proportionality (S²-K²/kJ²)

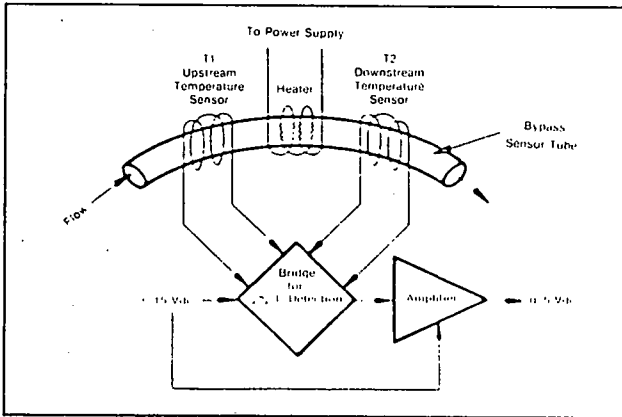

Figure 3-1 Flow Sensor Operational Diagram

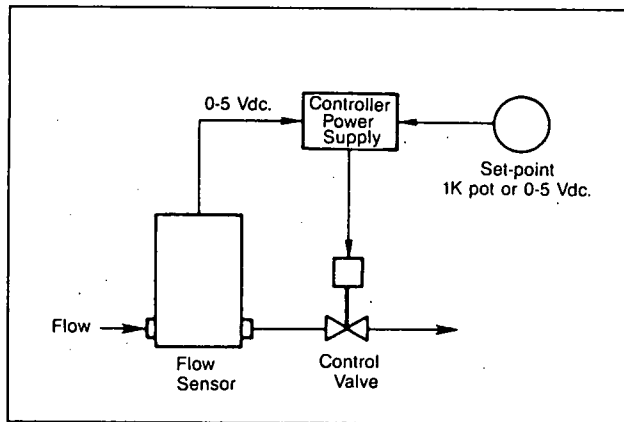

Figure 3-2 Control System Blockdiagram

A bridge circuit interprets the temperature difference and a differential amplifier generates a linear 0-5 Vdc signal directly proportional to the gas mass flow rate. A flow restrictor performs a ranging function similar to a shunt resistor. This restrictor provides a pressure drop that is linear with flow rate. The sensor tube has the same linear pressure drop/flow relationship. The ratio of the restrictor flow to the sensor tube flow remains constant over the range of the meter. Different restrictors have different pressure drops and produce meters with

different full scale flow rates. The span adjustment in the electronics affects the fine adjustment of the meters full scale flow.

In addition to the mass flow sensor the Model 5850TR Mass Flow Controller has an integral control valve and control circuit. The control circuit senses any difference between the flow sensor signal and adjusts the current in the modulating solenoid valve in increase or decrease the flow.

The printed control board offers you the following features:

- soft start

- valve override

and a setpoint input for 0-5Vdc or 0-10Vdc signal, or a command potentiometer.

- precision reference voltage is provided to drive the command potentiometer.

The voltage is presented to the whiper by the voltage divider action and is applied to the command input of the controller.

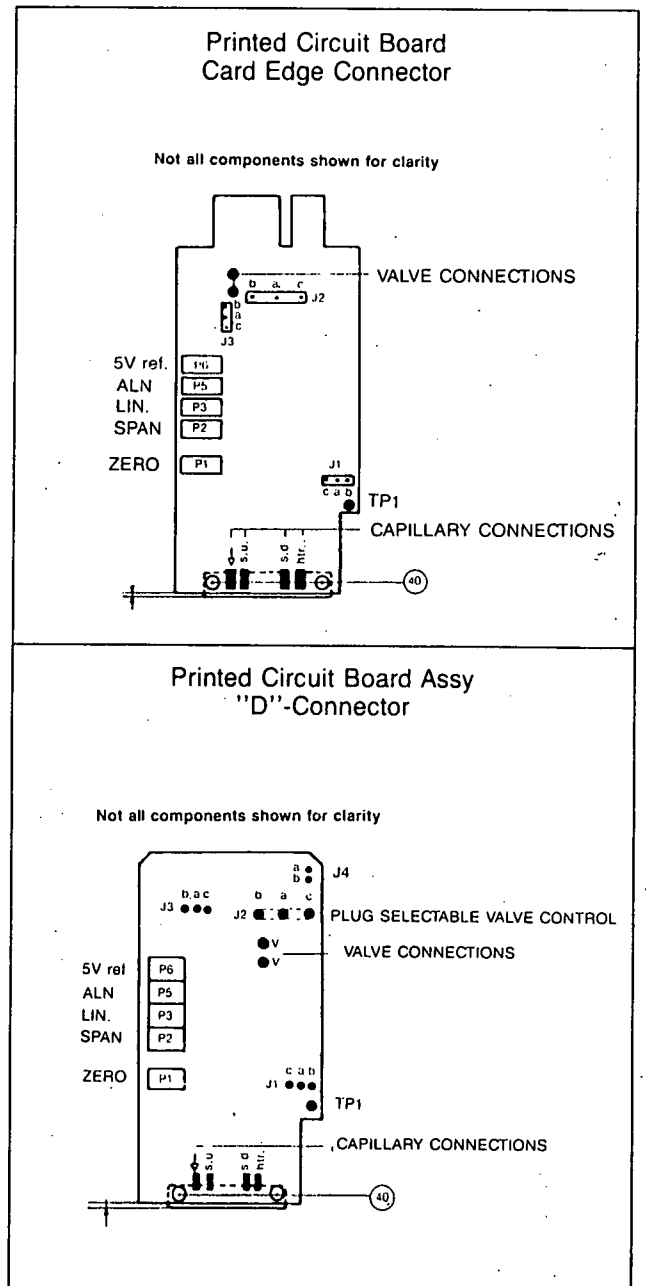

Figure 3-3 Printed Circuit Board Assy

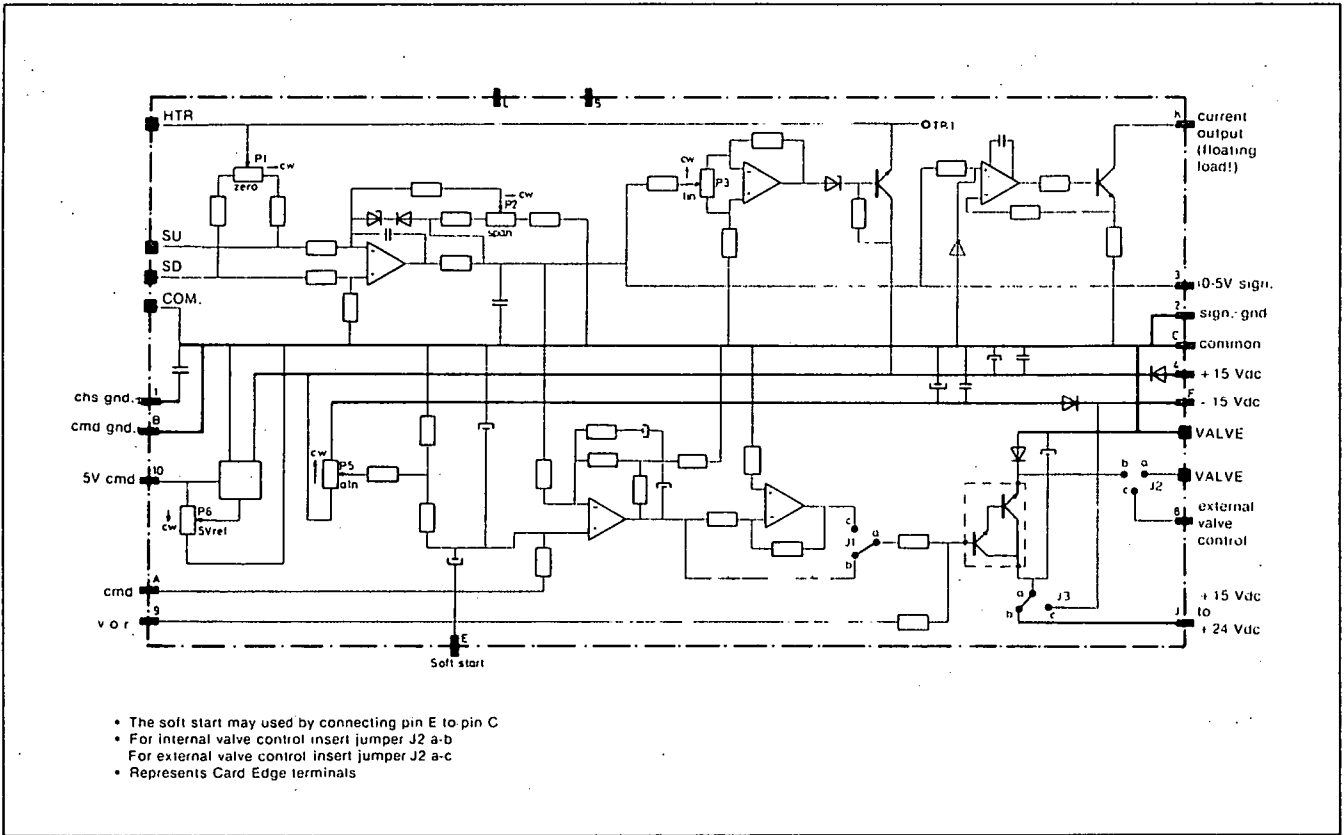

Figure 3-4
Schematic Diagram 5850TR Electronics with
Card Edge Connections

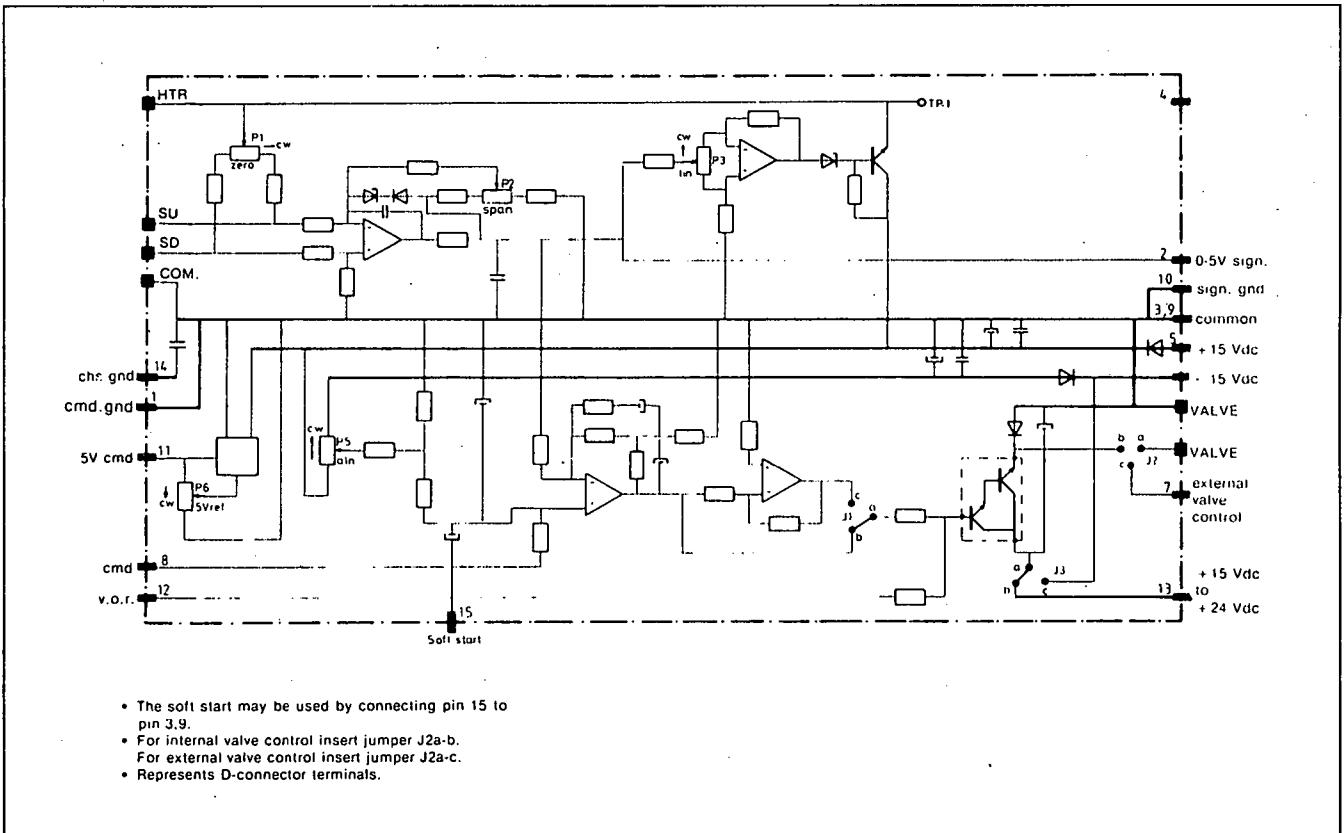

Figure 3-5
Schematic Diagram 5850TR Electronics with
"D"-Connector

3-2 Operating procedure (refer to figure 2-2 to 2-5 Customer Hook-up Diagram).

- A. Apply power to the M.F.C. and allow approximately 45 minutes for the instrument to warm up and stabilize.
- B. Turn on gas supply.
- C. Command 0% flow and observe the controller's output signal.
The output should be slightly positive: +15 mVdc for the N.C. Valve and +100 mVdc for the N.O. Valve.
- D. Set command for desired flowrate to assume normal operation.

3-3 Zero Adjustment

Each 5850TR is factory adjusted to provide a +15 mVdc signal at zero flow. The adjustment is made in our calibration laboratory which is temperature controlled. After initial installation and warm-up in the gas system the zero flow indication may be other than the factory setting. This is primarily caused by changes in temperature between our calibration laboratory and the final installation. The zero flow reading can also be affected to a small degree by changes in line pressure and mounting attitude. To check zero always mount the controller in its final configuration and allow a minimum of 20 minutes for the temperature of the controller and its environment to stabilize. Using a suitable voltmeter check the controller output signal. If it differs from the factory setting adjust it by removing the lower pot hold plug, which is located closest to the controller body. Adjust the zero potentiometer (refer to Figure 3-3) until the desired output signal is obtained.

3-4 Calibration procedure (refer to figure 3-3 to 3-6).

NOTE:

Calibration of the 5850TR mass flow controller requires the use of a digital voltmeter (DVM) and a primary flow standard calibrator such as the Brooks 'Vol-U-Meter'. It is recommended that the calibration be performed only by trained and qualified service personnel.

If the mass flow controller is to be used on a gas other than the calibration gas, apply the appropriate sensor conversion factor. Size the orifice for actual operating conditions.

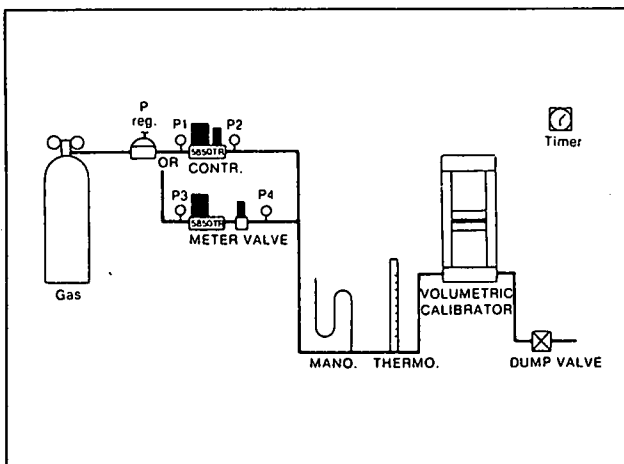

Figure 3-6
Typical Calibration Installation

The calibration procedure is written for all M.F.C. models, please refer only to those chapters which are applicable.

With the meter installed in an unpressurized gas line, apply power and allow approximately 45 minutes for warm up. During the warm-up, adjustment and calibration check procedures do not allow the control valve to open when gas flow is not present. This situation is not a normal operation mode, it will cause the control valve to heat up abnormally. A meter with an abnormally warm valve will be difficult to calibrate. This situation can be prevented by switching the valve override "closed" when there is no gas flow. Also avoid unnecessary periods with the valve override "open".

1-Reference, P6

Ref. adjustment. -Connect D.V.M. positive lead to the command potentiometer terminal CW.

- Card Edge, voltage output, pin 10, negative to command pin B.
- Sub "D", pin 11 and negative to command pin 1. Adjust Ref P6 for 5.000 V.

2-Zero, P1

ZERO adjustment - Connect DVM positive to the output and DVM negative to the signal common. Adjust Zero, P1 for +15 mV \pm 2 mV.

3-Alignment, P5

ALN. adjustment- Set command potentiometer to 100%. Adjust ALN P5 for 5.000V flow output.

- Card Edge, voltage output; connect DVM positive lead to the output pin 3, and negative to pin 2.
- Sub "D", connect positive lead to the output pin 2 and negative to pin 10.

4-Total Error

Set the command potentiometer to 10% of ref. voltage (0,500V)

Check and record output reading. The difference (in millivolts) between the command and output is "Total Error".

5-Alignment, P5

ALN adjustment, P5 to minus one-half of error.

6-Linear, P3

LIN adjustment. -Set command potentiometer to 100%, with DVM connected to TP1, adjust LIN (P3) for 11,0V.

7-Span, P2

SPAN adjustment -With command potentiometer at 100%, using suitable volumetric calibration equipment, adjust SPAN P2 for proper full scale flow.

8-Zero, P1

Set command potentiometer to 0% of flow.

Connect DVM positive to output and readjust zero (P1) for 15mV \pm 2 mV.

9-LIN adjustment

Set command potentiometer to 50% of flow and measure the flow rate using suitable volumetric calibration equipment.
Calculate the error as a percentage of full scale.

$$\text{Full scale error} = \frac{100\% (\text{measured flow rate} - \text{desired flow rate})}{\text{F.s. flow rate}}$$

Example:

What is the percent of full scale error when
F.s. = 100 ml_n/min.

Measured flow rate = 51,5 ml_n/min.
Desired flow rate = 50,0 ml_n/min.

$$\text{Full scale error} = \frac{100 (51,5 - 50)}{100} = 1,5\%$$

Note:

If the result of the percentage of error calculation is negative, be sure the "negative" percentage of error is used when calculating the TP1 voltage.

10-

Set command potentiometer to 100% of flow.
Note the voltage at TP1.
Calculate the new TP1 voltage: (the error from step 9) times (-0,178 V/%).

Example:

If step 9 error = 1,5%
and TP1 voltage = 11,000V
Then the new TP1 = 1,5% x (-0,178 V/%) + 11V
= -0,267 V + 11V
= 10,733 V

*A linearity adjustment factor units = volts/percent.

11-

Adjust LIN (P3) for new TP1 voltage.

12-

Repeat steps 7, 8 and 9. If the error from step 9 is less than 0,5% then calibration is complete.
If not, then repeat steps 10, 11 and 12.

3-5 Sizing of the Control Valve

When a change of the flow conditions is required; it may be necessary to change the flowrestrictor (refer to par. 4-4) and orifice size.

When calculating the Kv-value following information is required.

For proper sizing following information is required:

Upstream pressure P1 (Abs) Bar
Downstream pressure P2 (Abs) Bar
Gas temperature T (Kelvin)
Maximum flow Q (m³_n/h)
Gas density φ (kg/m³_n)

Depending on the ratio between P1 and P2, we have to make different calculations:

● Over critical, when $\frac{P2}{P1} > 0,5$

$$Kv = \frac{Q \text{ max.}}{514} \times \sqrt{\frac{\varphi \times T}{(P1-P2) \times P2}}$$

● Under critical, when $\frac{P2}{P1} \leq 0,5$

$$Kv = \frac{Q \text{ max.}}{257 \times P1} \times \sqrt{\varphi \times T}$$

The table 3-5-1 refers to the Kv-values and appropriate orifice sizes.

The next largest orifice size should be selected in case of interpolation.

3-5-1- Kv-Values and max. Acceptable Pressure Drop over the Valve.

Kv value (m ³ _n /h)	Orifice diameter (inch)	Max. ΔP(Bar)	Partnumber
5 x 10 ⁻⁶	0,0013"	500	577-Z-363-BMT
2 x 10 ⁻⁵	0,002"	500	577-Z-364-BMT
5 x 10 ⁻⁵	0,003"	350	577-Z-365-BMT
11 x 10 ⁻⁵	0,004"	230	577-Z-366-BMT
18 x 10 ⁻⁵	0,005"	160	577-Z-367-BMT
4 x 10 ⁻⁴	0,007"	100	577-Z-368-BMT
9 x 10 ⁻⁴	0,010"	60	577-Z-369-BMT
2 x 10 ⁻³	0,014"	36	577-Z-401-BMT
4,7 x 10 ⁻³	0,020"	22	577-Z-370-BMT
1,05 x 10 ⁻²	0,028"	13	577-Z-371-BMT
1,4 x 10 ⁻²	0,032"	11	577-Z-372-BMT
3,3 x 10 ⁻²	0,048"	6	577-Z-137-BMT

Section 4 MAINTENANCE

4-1 General

No routine maintenance is required on the Model 5850 TR other than an occasional cleaning. If an in-line filter is used, the filtering element should periodically be replaced or ultrasonically cleaned.

4-2 Control valve (refer to figure 5-1)

The control valve may be disassembled in the field by the user for cleaning or servicing.

Disassemble the valve as follows:

1. remove the jam nut (14) on top of the valve assembly.
2. remove the screw (5) and cover (3) of the controller.
3. remove the coil housing (13) (including item 12 and 11).
4. **carefully** remove the stem assembly (1) as not to bend the lower guide spring (9).
5. remove plunger assembly (16).
6. remove orifice (19).

Clean the parts and carefully assemble in reverse of the above procedure.

O-ring seals should be inspected and may need to be replaced during the maintenance procedure. O-ring seals must be lubricated with HALO-CARBON 25-10M grease prior to installation.

NO LUBRICATION SUBSTITUTE IS RECOMMENDED.

4-3 Trouble shooting

CAUTION: It is important that this instrument be serviced only by properly trained and qualified personnel.

System Checks

The 5850TR is generally used as a component in gas handling systems which can be quite complex. This can make the task of isolating a malfunction in the system a difficult one. An incorrectly diagnosed malfunction can cause many hours of unnecessary downtime. If possible, make the following system checks before removing a suspected defective mass flow controller for bench troubleshooting or return, especially if the system is new:

1. Verify that the process gas fittings have been correctly connected and leak checked.
2. If the mass flow controller appears to be functioning but cannot achieve set-point, verify that sufficient inlet pressure and pressure drop are available at the controller to provide the required flow.

WARNING:

If it becomes necessary to remove the controller from the system after exposure to toxic, pyrophoric, flammable, or corrosive gas, purge the controller thoroughly with dry inert gas such as nitrogen, before disconnecting the gas connections. Failure to correctly purge the controller could result in fire, explosion, or death. Corrosion or contamination of the mass flow controller upon exposure to air may also occur.

Trouble	Possible cause	Check, corrective action
NO OUTPUT	No power in	1. Check for ± 15 Vdc power supply
	Obstruction in sensor	1. Flush sensor in both directions with non-residuous solvent. Air dry thoroughly. Do not attempt to service or disassemble sensor. 2. Return to factory.
	P.C. Board failure	1. Return to factory.
WILL NOT ZERO	Gas leak	1. Check downstream gas connection 2. Return to factory.
	P.C. Board failure	1. Return to factory
OUT OF CALIBRATION	Gas leak	1. Check all gas connections
	Dirty sensor	1. Flush with non-siduous solvent. Air dry thoroughly. Do not attempt to service or disassemble sensor. 2. Return to factory.
	Change in composition of metered gas	1. Refer to table 4-4-1 for conversion factor. 2. Return to factory.
	P.C. Board failure	1. Return to factory.
	Clogged restrictor	1. Ultrasonically clean. 2. Replace restrictor.

If any of the above services are performed, it is recommended calibration of the unit be verified using suitable volumetric calibration equipment.

4-4 Use of the Gas Conversion Table.

The Gas Conversion Table 4-4-1 is used to calculate the flowrate for gases other than the preselected gas.

The Mass Flow Controller is factory set to a preselected gas, pressure and flowrange. The flowrate accuracy of the new gas will generally be within $\pm 3\%$ of the calculated flow at any output, repeatability remains $\pm 0,2\%$ full scale.

To change to a new gas, multiply the output reading by the ratio of the gasfactor for the desired gas, to the gasfactor for the calibration gas.

Actual gas flow rate =

$$\text{Output reading} \times \frac{\text{factor new gas}}{\text{factor calibrated gas}}$$

Or for example:

The controller is calibrated for N_2

The desired gas is CO_2

Output reading is 75 ml_n/min.

Then:

$$\text{Actual gas flow rate } CO_2 = 75 \times \frac{0,77}{1,00}$$

$$= 57,75 \text{ ml}_n/\text{min.}$$

In order to calculate the conversion factor for a gas mixture the following formula should be used:

Sensor Conversion	100			
	$\frac{P1}{1,00}$	+	$\frac{P2}{1,00}$	+
Factor Mixture	Conv. factor Gas 1		Conv. factor Gas 2	Conv. factor Gas n

Where:

P1 = percentage (%) of gas 1 (by volume)

P2 = percentage (%) of gas 2 (by volume)

Pn = percentage (%) of gas n (by volume)

Example:

The desired gas is 20% Helium (He) and 80% Chlorine (Cl_2) by volume. The desired full scale flow rate of the mixture is 20 ml_n/min.

Sensor conversion factor for the mixture is:

$$\text{Factor Mixture} = \frac{100}{\frac{20}{1,39} + \frac{80}{0,83}} = 0,903$$

$$\text{Air equivalent flow} = 20/0,903 = 22,15 \text{ ml}_n/\text{min.}$$

It is generally accepted that the mass flow rate derived from this equation is only accurate to $\pm 3\%$. The sensor conversion factors given in Table 4-4-1 calculated based on a gas temperature of 21°C and a pressure of 1 Bar abs. The specific heat of most gases are not strongly pressure and temperature dependent, however, gas conditions that vary widely from these reference conditions may cause an additional error due to the change in specific heat due to temperature and/or pressure.

Table 4-4-1 Gas conversion factor chart.

USE OF THE CONVERSION TABLE

The conversion table is used to determine the flow rate for gases other than the preselected gas.

The flowmeter is factory set to a preselected gas (mostly air), pressure and flow range.

To change to a new gas, multiply the output reading by the factor, in cases the flowmeter is calibrated on air or Nitrogen.

Gas	Symbol	Specific Heat Cp at 25°C and 1 Atm. J/mole K	Toxic	Flammable	Sensor Conversion Factor*	Density kg/m ³ _n
Acetylene	C ₂ H ₂	44.308	No	Yes	0.657	1.173
Air	-	29.13	No	No	1.000	1.293
Allene	C ₃ H ₄	60.84	No	Yes	0.479	1.787
Ammonia	NH ₃	36.953	Yes	Yes	0.788	0.771
Argon	Ar	24.83	No	No	1.398	1.784
Arsine	AsH ₃	38.522	Yes	Yes	0.756	3.478
Boron Trichloride	BCl ₃	65.655	Yes	No	0.444	5.227
Boron Trifluoride	BF ₃	50.242	Yes	No	0.580	3.025
Bromine Pentafluoride	BrF ₅	101.4	Yes	Yes	0.287	7.806
Bromine Trifluoride	BrF ₃	66.65	Yes	Yes	0.440	6.108
Butane	C ₄ H ₁₀	100.365	No	Yes	0.290	2.593
Butene	C ₄ H ₈	87.329	No	Yes	0.334	2.503
Carbon Dioxide	CO ₂	37.564	No	No	0.775	1.977
Carbon Monoxide	CO	29.204	Yes	Yes	0.997	1.250
Carbon Tetrachloride	CCl ₄	84.438	Yes	No	0.345	6.860
Carbonyl Fluoride	COF ₂	108.5	Yes	Yes	0.268	2.045
Carbonyl Sulfide	COS	42.752	Yes	Yes	0.681	2.680
Carbon Tetrafluoride (Freon 14)	CF ₄	61.27	No	No	0.475	3.906
Chlorine	Cl ₂	35.317	Yes	Yes	0.825	3.214
Chloroform	CHCl ₃	65.756	Yes	Yes	0.443	5.323
Chlorine Trifluoride	ClF ₃	67.117	Yes	Yes	0.434	4.125
Cyanogen	(CN) ₂	38.338	Yes	Yes	0.499	2.322
Cyclopropane	C ₃ H ₆	57.559	Yes	Yes	0.506	1.877
Deuterium	D ₂	29.204	No	Yes	0.997	0.177
Diborane	B ₂ H ₆	53.346	Yes	Yes	0.546	1.235
Dichlorosilane	SiH ₂ Cl ₂	65.73	Yes	Yes	0.443	4.506
Dimethylamine	(CH ₃) ₂ NH	43.428	Yes	Yes	0.671	2.011
Dimethylether	(CH ₃) ₂ O	49.40	Yes	Yes	0.590	2.055
Ethane	C ₂ H ₆	53.346	No	Yes	0.546	1.357
Ethyl Chloride	C ₂ H ₅ Cl	102.090	Yes	Yes	0.285	2.879
Ethylene	C ₂ H ₄	43.428	No	Yes	0.620	1.261
Ethylene Oxide	C ₂ H ₄ O	49.40	Yes	Yes	0.590	1.965
Fluorine	F ₂	31.449	Yes	Yes	0.926	1.695
Fluoroform (Freon 23)	CHF ₃	51.557	No	No	0.565	3.127
Freon 11	CCl ₃ F	77.613	No	No	0.375	6.281
Freon 12	CCl ₂ F ₂	74.469	No	No	0.391	5.492
Freon 13	CClF ₃	67.655	No	No	0.431	4.912
Freon 13 B1	CBrF ₃	70.590	No	No	0.413	6.615
Freon 21	CHCl ₂ F	63.7	-	-	0.457	4.912
Freon 22	CHClF ₃	57.524	No	No	0.506	3.906
Freon 113	C ₂ Cl ₃ F ₃	126.10	No	No	0.231	7.920
Freon 114	C ₂ Cl ₂ F ₄	112.992	No	No	0.258	7.479
Freon 115	C ₂ ClF ₅	121.38	-	-	0.274	7.165
Freon 116	C ₂ F ₆	126.65	No	No	0.227	6.139

* Nitrogen equals 1.000 for conversion factors.

Table 4-4-1 Gas Conversion factor chart. (Continued)

Gas	Symbol	Specific Heat Cp at 25°C and 1Atm.J/mole K	Toxic	Flammable	Sensor Conversion Factor*	Density kg/m ³ _n
Germane	GeH ₄	45.020	Yes	Yes	0.650	3.418
Helium	He	20.967	No	No	1.389	0.178
Hydrogen	H ₂	28.851	No	Yes	1.010	0.090
Hydrogen Bromide	HBr	29.791	Yes	-	0.978	3.645
Hydrogen Chloride (Dry)	HCl	29.576	Yes	No	0.985	1.639
Hydrogen Fluoride	H.F.	16.155	Yes	No	1.000	0.893
Hydrogen Iodide	H.I.	30.497	Yes	Yes	0.955	5.789
Hydrogen Selenide	H ₂ Se	34.752	Yes	Yes	0.838	3.613
Hydrogen Sulfide	H ₂ S	34.218	Yes	Yes	0.851	1.539
Isobutane	C ₄ H ₁₀	94.163	No	Yes	0.309	3.593
Isobutylene	C ₄ H ₈	86.883	No	Yes	0.335	2.503
Krypton	Kr	21.037	No	No	1.385	3.708
Methane	CH ₄	35.941	No	Yes	0.810	0.717
Methyl Bromide	CH ₃ Br	45.020	Yes	No	0.647	4.236
Methyl Chloride	CH ₃ Cl	42.326	No	Yes	0.688	2.308
Methyl Fluoride	CH ₃ F	38.171	No	Yes	0.763	1.518
Methyl Mercaptan	CH ₄ S	49.491	Yes	Yes	0.589	2.146
Neon	Ne	20.786	No	No	1.401	0.902
Nitric Oxide	NO	29.227	Yes	No	0.997	1.339
Nitrogen	N ₂	28.98	No	No	1.005	1.251
Nitrogen Dioxide	NO ₂	78.99	Yes	No	0.760	2.052
Nitrogen Trifluoride	NF ₃	53.371	-	-	0.546	3.168
Nitrogen Trioxide	N ₂ O ₃	65.618	Yes	No	0.444	3.389
Nitrous Oxide	N ₂ O	38.635	No	No	0.754	1.964
Oxygen	O ₂	29.427	No	No	0.990	1.429
Perchloryl Fluoride	ClO ₃ F	-	-	-	0.449	4.571
Phosgene	COCl ₂	57.693	Yes	No	0.505	4.418
Phosphine	PH ₃	37.126	Yes	Yes	0.785	1.517
Phosphorus Pentafluoride	PF ₅	-	Yes	No	0.347	5.620
Propane	C ₃ H ₈	74.01	No	Yes	0.394	2.008
Propylene	C ₃ H ₆	62.345	No	Yes	0.467	1.875
Silane	SiH ₄	42.844	Yes	Yes	0.680	1.44
Silicon Tetrafluoride	SiF ₄	73.492	Yes	No	0.396	4.648
Sulfur Dioxide	SO ₂	39.884	Yes	No	0.730	2.858
Sulfur Hexafluoride	SF ₆	97.152	No	No	0.300	6.516
Trimethylamine	(CH ₃) ₃ N	91.931	Yes	Yes	0.317	2.639
Tungsten Hexafluoride	WF ₆	-	-	-	0.290	13.28
Uranium Hexafluoride	UF ₆	-	-	-	0.220	15.70
Vinyl Bromide	C ₂ H ₃ Br	55.531	Yes	Yes	0.525	4.772
Vinyl Chloride	C ₂ H ₃ Cl	53.607	Yes	Yes	0.543	2.788
Vinyl Fluoride	C ₂ H ₃ F	50.459	No	Yes	0.577	2.046
Xenon	Xe	21.012	No	No	1.386	5.851

* Nitrogen equals 1.000 for conversion factors.

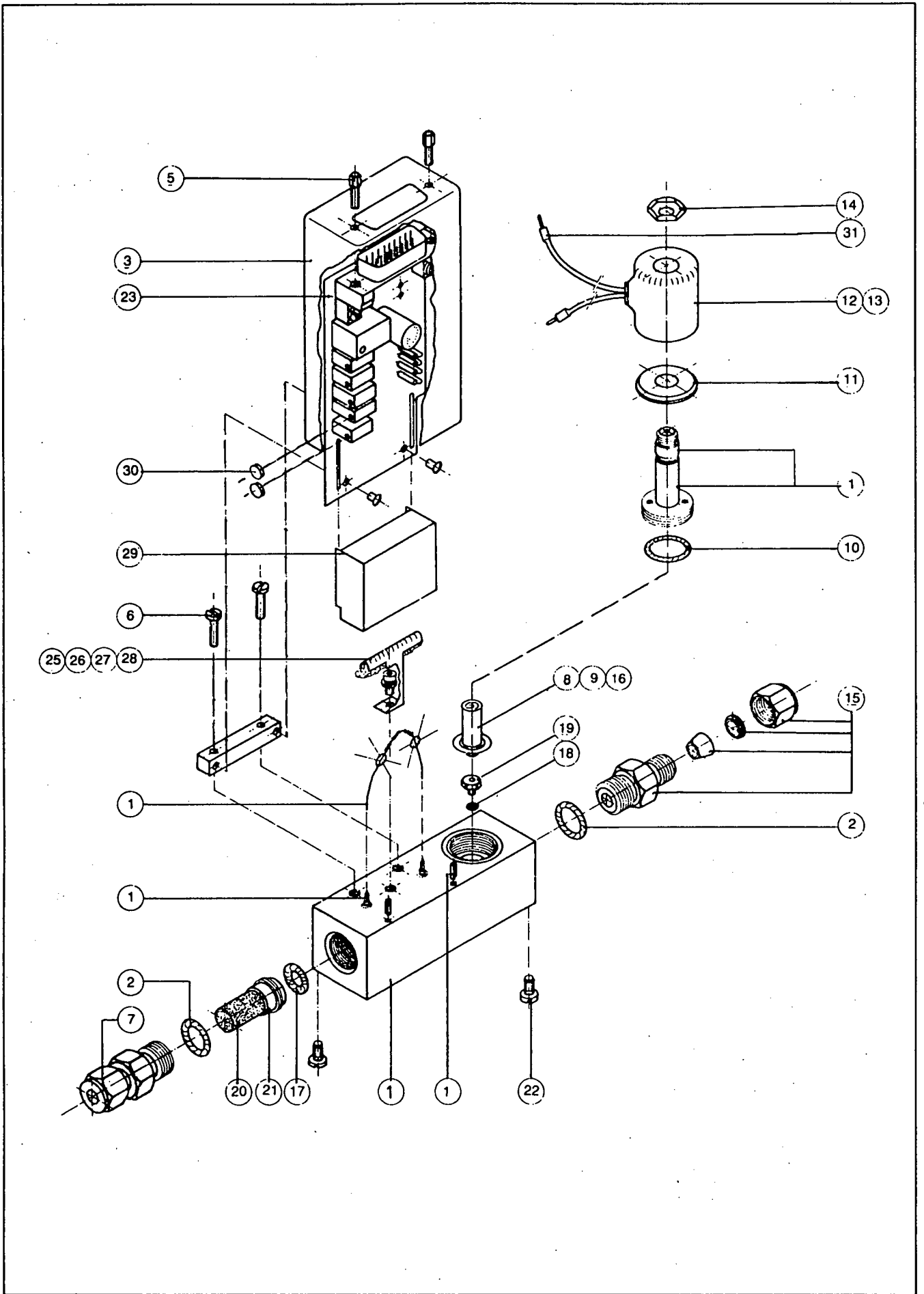

Figure 5-1
Exploded view 5850TR

5-1 Recommended spare parts 5850TR with N.C. valve, 100 Bar

Ref.no.	Quantity required	Description	Part number
1	1	Transducer body M.F.C. Sensor	092-B-033-BMA 092-B-036-BMA
2	2	O-ring for adapters Viton Teflon Buna-N	375-B-906-QTA 375-B-906-QMA 375-B-906-SUA
3	1	Housing cover Card Edge connection sub "D"-connection sub "D"-connection (sensor)	219-Z-190-EAA 219-Z-241-EAA 219-Z-243-EAA
5	2 1	Cil. screw Card Edge connection Mounting set sub "D"-connection	753-G-267-AAA 760-Z-037-ACS
7	1	Inlet Adapters (incl. filter) 1/4" tube comp. fittings 1/8" tube comp. fittings 1/4" VCR 1/4" NPT 6 mm tube comp. fittings 3/8" tube comp. fittings	320-B-080-BMA 320-B-083-BMA 014-Z-358-BMA 014-C-203-BMA 320-B-092-BMA 320-B-085-BMA
8	1	Seat assembly Viton Teflon Kalrez Buna-N	715-Z-046-AAA 715-Z-041-AAA 715-Z-162-AAA 715-Z-123-AAA
9	1	Lower guide spring	820-Z-073-BBA
10	1	O-ring valve seal Viton Teflon Buna-N	375-B-016-QTA 375-B-016-QMA 375-B-016-SUA
11	1	Filflix plate	613-E-444-ACJ
12	1	Coil	183-Z-128-AAA
13	1	Coil housing	441-Z-180-AAA
14	1	Nut	575-Z-011-ACJ
15	1	Outlet adapters 1/4" tube comp. fittings 1/8" tube comp. fittings 1/4" VCR 1/4" NPT 6 mm tube comp. fittings 3/8" tube comp. fittings	320-B-079-BMA 320-B-082-BMA 014-Z-357-BMA 014-C-202-BMA 320-B-091-BMA 320-B-150-BMA
16	1	Plunger assy	622-Z-108-AAA
17	1	O-ring filter bushing Viton Teflon Buna-N	375-B-109-QTA 375-B-109-QMA 375-B-109-SUA
18	1	O-ring under orifice Viton Teflon Buna-N	375-G-042-QTA 375-G-042-QMA 375-G-042-SUA
19	1	Orifice 0,0013" 0,002" 0,003" 0,004" 0,007" 0,010" 0,014" 0,020" 0,028" 0,032" 0,048" 0,052" 0,067"	577-Z-363-BMT 577-Z-364-BMT 577-Z-365-BMT 577-Z-366-BMT 577-Z-368-BMT 577-Z-369-BMT 577-Z-401-BMT 577-Z-370-BMT 577-Z-371-BMT 577-Z-372-BMT 577-Z-137-BMT 577-Z-138-BMA 577-Z-139-BMA

5-1 Recommended spare parts 5850TR with N.C. valve, 100 Bar (continued)

		Min. full scale	Max. full scale		
20 + 21	1	Restrictor assy	6,1	8,7 ml _n /min	110-Z-159-BMA
		Restrictor assy	8,6	12,1 ml _n /min	110-Z-160-BMA
		Restrictor assy	12,0	17,0 ml _n /min	110-Z-161-BMA
		Restrictor assy	16,9	23,9 ml _n /min	110-Z-162-BMA
		Restrictor assy	23,6	33,4 ml _n /min	110-Z-163-BMA
		Restrictor assy	33,1	46,9 ml _n /min	110-Z-164-BMA
		Restrictor assy	46,3	65,6 ml _n /min	110-Z-165-BMA
		Restrictor assy	64,8	91,7 ml _n /min	110-Z-166-BMA
		Restrictor assy	90,8	129 ml _n /min	110-Z-167-BMA
		Restrictor assy	127	180 ml _n /min	110-Z-168-BMA
		Restrictor assy	178	252 ml _n /min	110-Z-169-BMA
		Restrictor assy	249	352 ml _n /min	110-Z-170-BMA
		Restrictor assy	349	494 ml _n /min	110-Z-171-BMA
		Restrictor assy	488	691 ml _n /min	110-Z-231-BMA
		Restrictor assy	683	967 ml _n /min	110-Z-232-BMA
		Restrictor assy	958	1360 ml _n /min	110-Z-233-BMA
		Restrictor assy	1340	1890 ml _n /min	110-Z-234-BMA
		Restrictor assy	1870	2650 ml _n /min	110-Z-235-BMA
		Restrictor assy	2620	3710 ml _n /min	110-Z-236-BMA
		Restrictor assy	3670	5200 ml _n /min	110-Z-237-BMA
Restrictor assy	5140	7300 ml _n /min	110-Z-238-BMA		
Restrictor assy	7200	10200 ml _n /min	110-Z-239-BMA		
Restrictor assy	10100	14300 ml _n /min	110-Z-228-BMA		
Restrictor assy	14100	20000 ml _n /min	110-Z-226-BMA		
Restrictor assy	19800	28000 ml _n /min	110-Z-224-BMA		
23	1	P.C. Board N.C.;			097-B-107-ZZZ
		neg. valve volt, Card Edge conn. 0-5Vdc			
		P.C. Board N.C.;			097-B-115-ZZZ
		pos. valve volt, sub. "D"-conn. 0-5Vdc			
		P.C. Board N.C.;			097-B-177-ZZZ
		neg. valve volt. Card Edge conn. 0-10Vdc			
P.C. Board N.O.;			097-B-151-ZZZ		
neg. valve volt, Card Edge conn. 0-5Vdc					
P.C. Board N.O.;			097-B-156-ZZZ		
pos. valve volt, sub "D"-conn. 0-5Vdc					
30	1	Cap for trim pots			620-Z-434-SXA

5-1-1 Recommended spare parts 5850TR with N.O. valve, 100 Bar

Ref. no.	Quantity required	Description	Part number
1	1	Transducer body	092-B-063-BMA
23	1	P.C. Board neg. valve volt. Card Edge conn.	097-B-151-ZZZ
		pos. valve volt. Card Edge conn.	097-B-152-ZZZ
		pos. valve volt. sub "D" conn.	097-B-156-ZZZ
40	1	Nut	573-Q-074-ACD
41	1	O-ring sleeve seal Viton	375-B-012-QTA
		Teflon	375-B-012-QMA
42	1	Plunger extension	830-Z-045-BMA
43	1	Ring	724-Z-202-AAA
44	1	Seat assembly - Kalrez	715-Z-197-AAA
45	1	Plunger assy	622-Z-110-CEA
46	1	Spacer 0,05 mm	810-A-303-BMA
47	1	Spacer 0,2 mm	810-A-304-BMA

5-1-2 Recommended spare parts 5850TR with N.C. valve, 300 Bar

Ref. no.	Quantity required	Description	Part number
1	1	Transducer body	092-B-064-BMA
11	1	Fillfix Plate	613-E-452-ACJ
16	1	Plunger assy	622-Z-111-AAA

5-1-3 Service Tools

Quantity required	Description	Part number
1	5850 M.F.C. toolkit	778-D-017-AAA
1	Stem removal tool	908-Z-048-AAA
1	Orifice removal tool	908-Z-035-AAA

Repair Policy

Normal turn-around time is less than five (5) working days on any standard item returned for service. This applies to any product whether it is returned for warranty work or beyond warranty.

Guarantees

If at any time within one year after shipment, but not thereafter, it is proved that any part of the equipment furnished by us was defective when shipped by us, we will repair or replace the same free of charge, F.O.B. our plant. Notice of this claim must be made to us within one year after delivery. Our liability is limited to replacement of such defective parts or equipment. There are no guarantees or warranties expressed or implied other than those herein specifically mentioned.

Brooks Instrument Division shall not in any event be liable for any consequential damages, secondary charges, expenses for erection or disconnection, or losses resulting from any alleged defect in the apparatus. It is understood that corrosion or erosion of materials is not covered by our guarantee.

VLT® type 3002 - 3006
Standard control
200/230 V 380/415 V



175R0547

175R0547



Indhold:	Dansk	side	5
Contents:	English	page	10
Inhaltsverzeichnis:	Deutsch	Seite	15
Sommaire:	Français	page	21

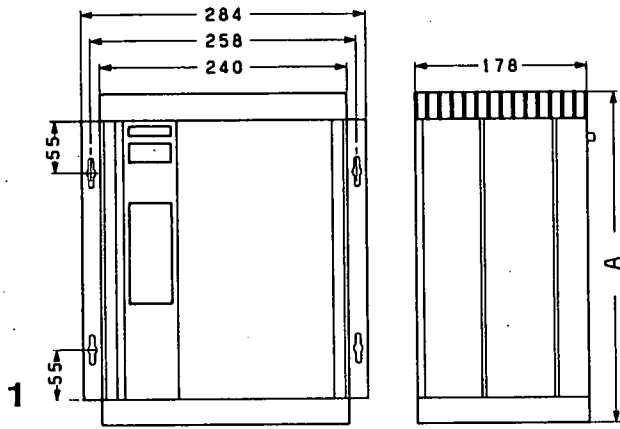

A [mm]	VLT®	3002-3004	3006
	IP00	300	440
	IP21	360	500
	IP54	530	530
	IP00 + option	440	550
	IP21 + option	500	610
	IP54 + option	530	640

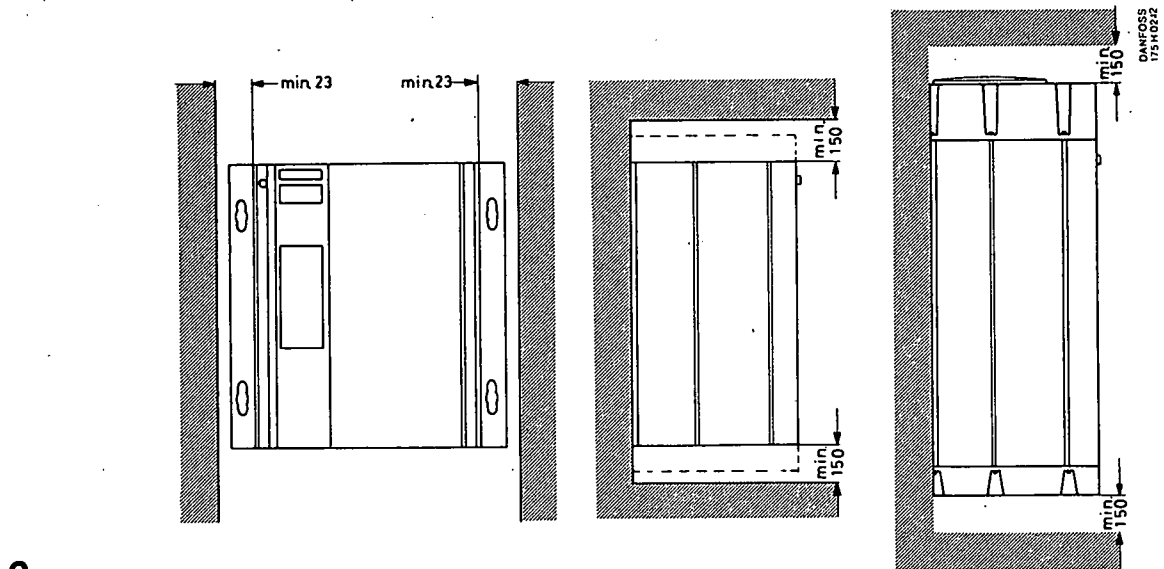
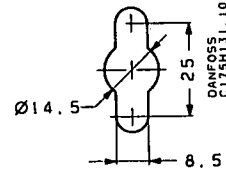

2

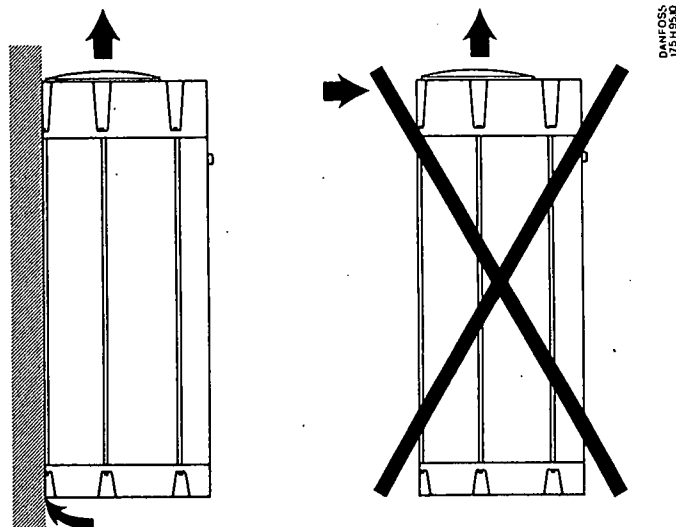

3

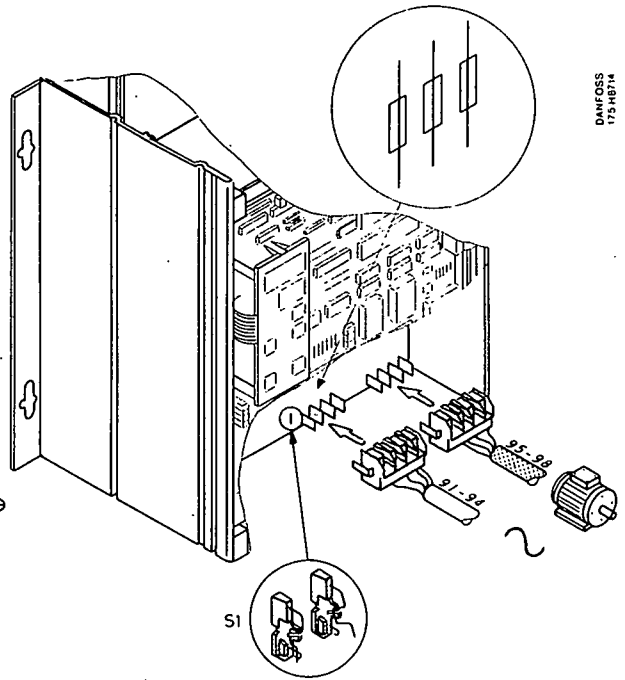
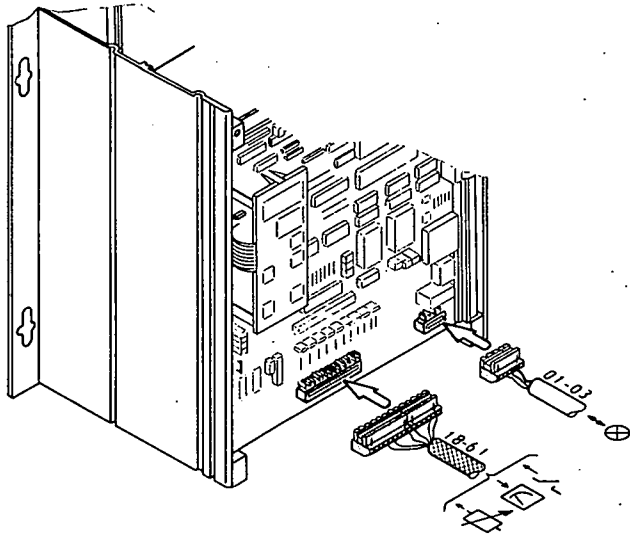

DANFOSS
C1754074

1

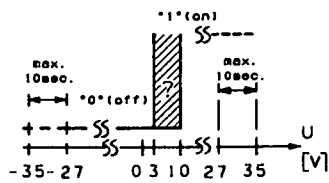
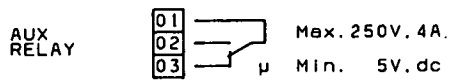
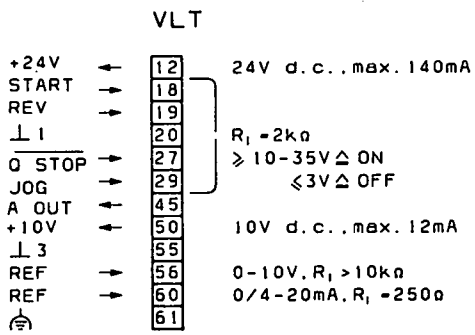

DANFOSS
C175482.11

2

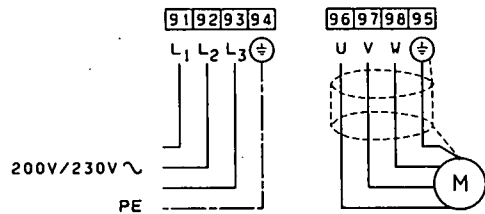

DANFOSS
C175487.10.10

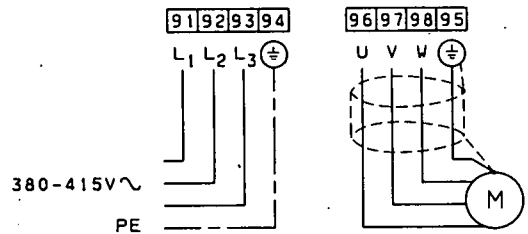

3

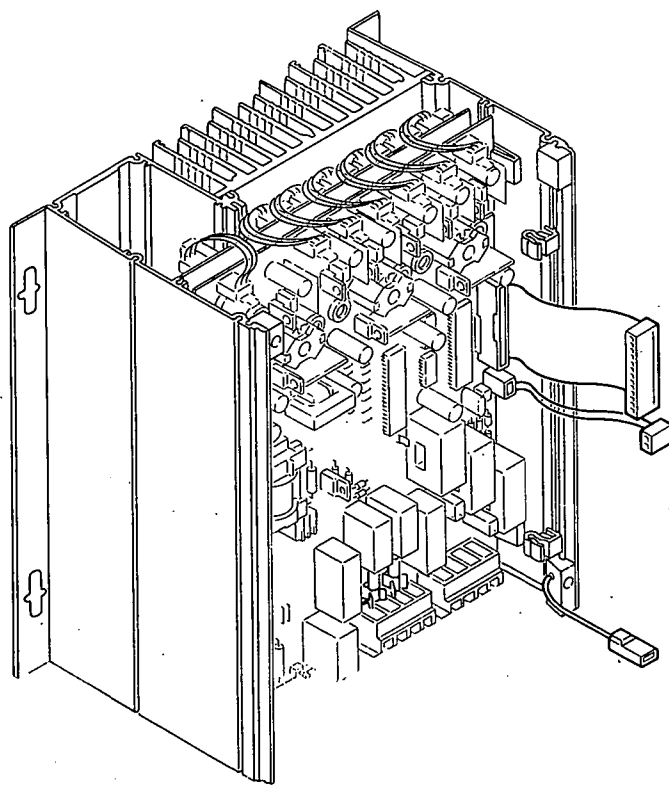
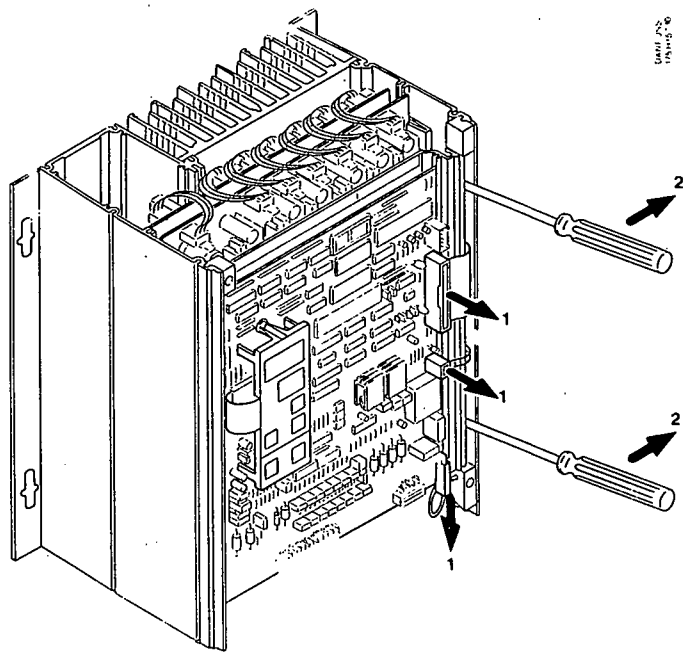

Warning:

- 1) Do not touch the electrical parts of the frequency converter when the supply voltage is connected and when the supply voltage has been disconnected wait at least four minutes before touching it.
- 2) When repairs are undertaken the power supply to the frequency converter must be disconnected. This is to prevent the motor starting without warning.
- 3) The pushbutton "Stop" (see page 26 fig. 1 pos. 2) does not disconnect the supply mains.

Introduction

The static VLT® frequency converters type 3002-3006 from Danfoss is an electronic unit for infinite control of the standard three phase asynchronous motor.

The frequency converter is available in the following versions:

- IP00, basic version, which can be installed together with an IP21 enclosure, brake option or radio noise filter (RFI filter). Special instructions explaining installation and electrical connection procedures must be followed, when installing the IP21 enclosure, brake option or RFI filter.
- IP54 version which can be mounted with brake option and radio noise filter.

The instruction contains the following main points:

- Control signals
- Mechanical assembly
- Electrical connection
- Operation
- Basic settings
- Fault indication

Control signals

This section describes the connection possibilities of the frequency converter control card.

The control card is divided up into 2 groups:

- 1) Analog input from reference source.
 - Digital input for sequence control.
 - Analog output for monitoring.
- 2) Relay contact that can be used for an alarm function.

Analog inputs**Terminals 50-61**

The frequency converter registers the sum of the signals received on the reference inputs 56 and 60 and a reference frequency is calculated (see below)

Voltage output terminal 50 can supply the potentiometer (min. 1 kΩ). (See connection example page 30).

Terminals 56: voltage reference
Normal 0 - 10 V.

Terminal 60: Current reference
Can be programmed for either 0-20 mA or 4-20 mA signal in menu 24.

Digital inputs**Terminals 15 - 38**

The frequency converter registers the digital signals as "on" with voltages higher than 10 V, and as "off" with voltages lower than 3 V (24 V PNP logic). If voltages from 27 to 35 or from -27 to -35 V are applied, they must not be connected for more than 10 seconds, see page 3 fig. 3.

The digital inputs can be supplied via the voltage output of terminal 12.

Terminal 18 : Motor start.

To start, set the input to "on". There is a choice between different methods of connection. See menu 22.

Terminal 19: Reversing of motor.

To reverse set the input to "on". There is a choice between different methods of connection. See menu 22.

Terminal 27: Quick stop.

The input must be set to "on" during operation. If this connection is interrupted the motor stops without ramp operation. See stop possibilities in menu 23.

Terminal 29: Jogging speed.

To change to jogging speed, set the input to "on".

The jogging function can start the motor without "start" being activated. (It then runs without ramp operation).

Output signals

Terminal 45: Motor frequency / -current
A 0-20 mA or a 4-20 mA signal can be supplied.
(See menu 27 for selection possibilities).

Relay function**Terminals 01 - 03**

The relay contact can be activated by the signals: Ready, trip, run, current warning or thermal motor protection. (See menu 25).

Mechanical installation

The frequency converter is mounted direct on a wall or into a rack by means of the mounting fittings integrated with the unit. However the IP54 version must be mounted direct on a flat wall or plate, otherwise the air flow of the fan cannot follow the cooling ribs of the frequency converter. See page 2 fig. 3.

The frequency converter must be able to get rid of its surplus heat. Therefore air must pass freely under and over the rear wall ribs. The minimum distance to the surroundings appears from fig. 2 on page 2.

The maximum heat dissipation from the frequency converter Φ_{VLT} is:

VLT® type	3002	3003	3004	3006
Φ_{VLT} [W]	60	105	130	160

See separate instruction for mounting IP21 enclosure, brake option or RFI option.

Electrical connection

(The electrical connection to be made according to national rules and regulations).

- The connection plugs are removable. (Page 3 Fig. 1).
- The control signals are connected as shown on page 3 Fig. 1 and 2. The function of the control signal has been described in the section 'control signals'.
- The supply mains and the motor are connected as shown on page 3 Fig. 1 and 3.

3 connection examples are shown on page 30:

- 1) Simple analog control using VLA 10
- 2) PLC control with internal supply
- 3) PLC control with external supply

$$f_{REF} = \frac{\text{Actual reference} \times (f_{MAX} - f_{MIN})}{\text{Max. reference (10 V or 20 mA)}} + f_{MIN}$$

Note: Cables to the control signal and the motor must be screened in order to comply with radio noise regulations in accordance with VDE 0875 ,EEC directive 82/499 and EMC specifications.

The motor cable screen is connected to the earth in the frequency converter and in the motor.

The control cable screen is connected to a screened earth in the frequency converter. (Connection terminal 61). If unscreened cables are used, the control inputs can, occasionally be subject to signal disturbances. Normally such a disturbance will not effect the frequency converter.

Note:

High voltage test

With a high voltage test, terminals U, V, W, L1, L2 and L3 must be short circuited and the filter capacitors must be disconnected with switch S1 (see page 3, fig. 1 and 3).

Extra protection

An ELVB, neutral earthing or earthing can be used as extra protection. Due to rectified load, the ELCB must not be used with the frequency converter.

Operation

Use the keyboard of push buttons to operate and programme. The start and stop buttons (page 26, fig. 1, pos. 1 and 2) overrides remote control.

Remove the "programming key" if you do not want to operate and programme via the pushbuttons (see page 26 fig. 2).

The frequency converter has about 40 menus, each one connected to a set of data. The "arrow up" and "arrow down" buttons are used to change between menus. "Data" always displays the value for that actual menu and it is always this data value that is used when regulating. The values can be changed by using the "arrow up" or "arrow down" buttons when the "data" button is pushed in.

After 15 sec. with the same data value or when shifting to another menu the data value is stored so that it is not erased in case of power failure. (excepting menu 07)

The data field will flash when an attempt is made to change data to an undefined area or if an attempt is made to change the data value of menus 5, 14, 15 and 16 without stopping the motor first.

The menu field will flash when the frequency converter is stopped by activating the pushbutton "stop". The frequency converter cannot be restarted via the external start functions.

Basic setting

The menus for output and setting are divided into five groups:

- 1) **Display indication.** Here the actual operation values can be read out (menu 00 - 04 + menu 17)
- 2) **Application settings.** Here the frequency converter is programmed so that the control fits the application in question (menu 05-13).
- 3) **Motor data.** The frequency converter has been optimised on the basis of three recommended motor sizes: nominal, over-size and under-size (see menu 14). Menus 14, 15 16 and 41 are set to the rated motor values.
- 4) **Control and supervising:** In menus 22-40 a number of control and monitoring possibilities can be selected for the specific application.
- 5) **Motor compensation.** Menus 18-21 and menu 42 are only applied in special cases:
 - When the motor size used cannot be programmed in menu 14.
 - When the practical operation shows an unacceptably low starting torque, lacking speed stability, jerking motor operation etc.

Factory values have been recorded into the frequency converter. These can be changed as required. The factory values are given on page 32 in the column entitled "Typical value".

In most cases you can use the factory values.

It might be necessary to change the recorded values for single menus in the group "application setting" (menu 5-13). The menus of "motor data" must only be changed when the the size of the motor used is different from the size of motor recommended for the frequency converter, see page 12.

If the recorded factory data values have been changed it is a good idea to enter the new values in the form at the back of the instructions. This information will be very useful in connection with any re-programming.

Display indication

Menu 00

Customer selected display indication. (See below)

The reference value received from the remote control or via the keyboard can be seen on the display.

Setting of display with application rate factor, see menu 17.

At optimum slip compensation the read out value represents the speed of the motor shaft/machine. A display constant can be programmed (see menu 17)

Menu 17

You can make an input of an application rate factor to be read out in menu 00. The value can be set from 0.1 to 999. Example: Motor data = 50 Hz, 1500 RPM and input data value of 100: At synchronous motor speed (50 Hz) the figure 100 can be seen on the display. At a 50% motor speed the figure on the display is 50.

Menu 01

Readout the frequency converter output frequency in [Hz].

Menu 02

Readout the current motor voltage in [V]. (Measuring of motor voltage on the motor will be inaccurate due to high frequency switching).

Menu 03

Readout the actual motor current in [A].

Menu 04

Readout the current motor torque in %. The output is proportional to the motor efficiency current. 100% is the equivalent of the recorded nominal motor current. The motor torque is a calculated value where the magnetising current (menu 42) appears.

Note : Actual motor torque can be read out at a set constant torque in menu 5 only.

Application setting

Menu 05

Set of load torque characteristic and slip function.

The motor voltage/frequency ratio is set by selecting from the following functions:

Constant torque/power output:

Data value:

0: No slip compensation, reversing via terminal 19 (100)

1: Slip compensation active, reversing via terminal 19 (101)

If a brake option is used: Set the data value from 100-106 (The last digit follows the above)

$$\text{Menu 00} = \frac{\text{Actual reference frequency X Display constant (menu 17)}}{\text{Rated motor frequency (menu 16)}}$$

Quadratic torque applications:

(e.g. centrifugal pumps and fans)
You can choose among 3 factory programmed pump characteristics. However, here you may only use a motor size that can be programmed in menu 14, see "Motor data".

Data value:

- 4: Pump application 1. Optimised efficiency, low breakaway torque and low motor noise level.
- 5: Pump application 2. Optimised efficiency and medium breakaway torque.
- 6: Pump application 3. Optimised efficiency and high breakaway torque.

Menu 06

Set the operating location

Data value:

0: Local reference

Set the reference value in menu 07.

1: Remote control reference

Analog remote control reference:

The reference value is received via the analog input terminal or on the "jog speed" input.

Digital remote control reference:

(See menu 22, data 4-5)

See page 28

The reference value is received via the digital input "arrow up" and "arrow down" or on the "jog speed" input.

Note:

Local control:

To make the motor start set menu 23 for 0 or make a connection between terminals 12 and 27

Menu 07

Local reference [Hz]

Changes are only possible if the data value in menu 06 is 0.

If the mains supply is disconnected the reference value is 0.

Menu 08

Set the min. speed [Hz]

The value is recorded between 0 and max. speed (menu 09).

Menu 09

Set the max. speed [Hz]

The value is recorded between min. speed (menu 08) and 120 Hz.

Menu 10

Set the jogging speed [Hz]

The value is recorded between 0 and 120 Hz but the motor speed cannot exceed the max. speed.

The jogging speed can be lower than the min. speed.

Menu 11

Set the ramp-up time [s]

Set the ramp time between 0.1 and 360 seconds.

The ramp time indicates the acceleration time from 0 Hz to rated motor frequency (menu 16) provided that the current limit of the frequency converter is not activated

Menu 12

Set the ramp-down time [s]

Set the ramp time between 0.1 and 360 seconds.

The ramp time indicates the deceleration time from rated motor frequency (menu 16) to 0Hz, provided that the overvoltage limit of the frequency converter is not active.

With high breaking power it can be necessary to install a brake module.

Menu 13

Set the current limit [A]

The factory set value in menu 13 is the equivalent to a load of 160% torque.

It is possible to set a lower current limit. The motor will not start if the value is too low.

Motor data

Menu 14

Set the motor size [kW]

Read off the nominal power of the motor and record the value in kW. For a motor of 1.5 kW, record "1.5".

It is possible to make an input of three motor sizes: an under-size, a nominal size or an over-size.

On a frequency converter type 3003 (1.5 kW motor) there is thus a choice between data values 1.1, 1.5 or 2.2.

Menu 15

Set the motor voltage [V]

Record the motor nominal voltage with data values 200, 220, 230, 380, 400, 415 or 440.

Menu 16

Set the motor frequency [Hz]

Record the motor nominal frequency (break frequency) with data values 50, 60, 87 or 100.

Menu 41

Rated motor current [A].

Used for thermal motor protection and the torque display in menu 4. Enter the value from the motor nameplate.

Control and supervising.

Menu 22

Set the start, stop, reset and reversing functions.

There are six different methods of connection for input terminals 18, 19 and 29. See page 28.

Select the current connection and set the data value to the applicable value.

Data value:

0: Start and reversing activated with make contacts. Reversing is made with a make contact.

1: Motor speed is in the same direction as the switch is activated. Use the pulse switch to reset after trip.

2: The pulse switch is used to start/stop/and reset (stop and reset with break function). Use the switch to reverse.

3: The pulse switch is used for all functions (stop and reset with break function).

4: The start, stop and reversing functions on terminals 18 and 19 have been cancelled and replaced by "frequency UP" (18) and "frequency DOWN" (19). When terminal 29 is set to "ON" the actual analog reference is changed to the preprogrammed JOG reference. On the basis of that the speed can be changed through terminals 18 and 19.

5: As 4, but if terminal 29 is set to "ON" the actual analog reference is kept and on the basis of that the speed is now changed through terminals 18 and 19.

Menu 23

Set the quick stop or free-wheeling stop. For input terminal "Q-STOP", there are two ways to stop the motor (See page 29 fig 1).

Data value:

0: When the input cuts out, the motor brakes as fast as the motor and frequency converter permits..

1: When the input cuts out, the frequency converter "slips" the motor. The stop time depends on the inertia and friction of the system.

Menu 24

Set the analog reference input.

The reference signal, which can be received on terminal 60, can be registered in four ways.

The following are input signals with speed from min. frequency to maximum frequency.

Data value:

0: 0 - 20 mA

1: 4 - 20 mA

2: 20 - 0 mA

3: 20 - 4 mA

Menu 25

Set the relay function.

The relay, which is mounted on terminals 1, 2 and 3, is activated when the following is present.

Data value:

0: "Ready" signal.

1: "Trip" signal

2: "Run" signal

4: Current limit. Motor current is higher than the recorded value in menu 13.

6: Thermal overload: Based on time, current, voltage and frequency, the frequency converter calculates whether the motor thermal conditions are critical.

7: The frequency converter is "Ready" and the motor temperature is not critical (see "0" and "6").

8: As 7, and the control inputs are active for remote control (no local stop or reference)

11: The motor frequency is equal to the set reference.

Menu 27

Set the analog output function A OUT

The selected data value will affect output terminal 45 as follows:

Data value:

0: 0 - 20 mA for frequency = 0 - 100 Hz.

1: 4 - 20 mA for frequency = 0 - 100 Hz

2: 0 - 20 mA for frequency = 0 - max. frequency (see menu 09)

3: 4 - 20 mA for frequency = 0 - max. frequency (see menu 09)

4: 0 - 20 mA for received reference signal (see menu 00)

5: 4 - 20 mA for received reference signal (see menu 00)

11: "20" mA when the motor frequency is equal to the set reference.

100: 0-20 mA for the motor current = 0- I_{max} (160 % torque)

101: 4-20 mA for the motor current 0- I_{max} (160% torque)

102: 0-20 mA for the motor current = 0 - current limit in menu 13

103: 4-20 mA for the motor current = 0 - current limit in menu 13

104: 0-20 mA for the motor torque = 0 - max. (160 %)

105: 4-20 mA for the motor torque = 0 - max. (160 %)

111: "20" mA when the motor current is equal to the current limit set in menu 13

Menu 29

Thermal motor protection

The frequency converter calculates on the basis of voltage, current, frequency and time if the motor temperature exceeds the permissible limits.

The cut-out curve is sketched on page 30 fig. 4. Warning and trip are indicated by code 85 in the menu display.

Programme menu 25 for remote indication.

You can choose between the following reactions to a too high motor temperature:

Data value:

0: No warning, no trip

1: Warning, no trip

2: Warning and trip.

Menu 30

Set the method of reset after trip.

If trip is registered there is a choice between manual or automatic reset (fault entry).

If the cause of the error has gone, automatic reset is attempted after 5 seconds. If the cause of the error has not gone, manual reset must be used. (5 successive automatic resets, within 20 min. are permissible)

Data value:

0: Manual reset. The fault code is remembered with mains drop out.

1: Automatic reset. The fault code is not remembered with mains failure.

Warning: The frequency converter can start without warning.

Manual restart done in the following ways:

1) Terminal 27 set = "OFF" (see menu 22) or

2) press the stop and start button of the keyboards of the frequency converter
In special cases it may be necessary to disconnect and reconnect the supply voltage (see also menu 84)

Menu 34

Set the DC braking time [s].

The DC braking is connected with stop, and when the frequency is down to 1 Hz. Set the time where the DC braking is activated to between 0 and 15 s.

Menu 40

To re-programme the factory recorded data values.

Warning: All customer programmed data will be erased.

If factory recorded data values are required, use the following procedure:

1: Set the data value on 1 and change to the previous menu, or wait 15 s.

2: Disconnect the mains supply to the frequency converter. Wait 5 seconds and start up again.

Motor compensation

The settings of the menus 14, 15, 16, 18, 19, 20, 21, 41 and 42 vary according to the motor. The frequency converter is optimised on the basis of the three recommended motor sizes (see menu 14). In most applications the frequency converter can therefore control these motors without any problems. The menus 14, 15, 16 and 41 must only be set for the rated values of the motor. Set therefore first menus 14, 15, 16 and 41 as indicated and pass over menus 18, 19, 20, 21 and 42. For the connection between the values see page 29, fig. 3. Curve 1 is for no load operation and curve 2 is for loaded operation.

Menus 18, 19, 20, 21 and 42 to be set according to the guide lines given below in the following cases:

- The motor size used cannot be programmed in menu 14
- The starting torque of the practical operation is extremely low, unstable speed, motor operates in jerks etc.

- 1: Read the data value in menu 19 and note down the the value. Set then menu 19 for 0.
- 2: Start the motor unloaded and read the motor current in menu 03 at an output frequency of 5 Hz, 10 Hz, 25 Hz and 50 Hz. The measured current is the no-load current of the motor and the normal measuring result will be that the current is a little higher at high frequencies than at low frequencies.
- 3: If the currents deviate by more than 10% from each other the no-load characteristics of the motor is not typical and menus 18 and 21 must be set as follows:
 - a) If the current is too low at low frequencies: increase the start voltage in menu 18. The typical setting is 10% of rated motor voltage.
 - b) If the current is too high at high frequencies: reduce the voltage/frequency ratio in menu 21. The typical setting is 10% lower than the ratio between mains voltage and mains frequency.
- 4: Set menu 42 for a value being higher than the highest current measured.
- 5: Set then menu 19
Set this menu for the original value
- 6: Adjust
 - menu 19 if the dynamic torque is insufficient
 - menu 20 if the speed is unstable or if the load is varying.

Menu 18

Start voltage [V]

Setting range 0 to 99.9

No-load voltage at

0,1 X nominal motor frequency

To be set when several motors are operating in parallel and when the starting torque is insufficient.

In applications where several motors are operating in parallel the start voltage must normally be raised.

NOTE: If the set value for starting voltage is too high the frequency converter will operate in the current limit and then trip out.

Menu 19

Start compensation [V/A]

Setting range 0 to 99.9.

Must only be set if the dynamic torque is insufficient.

For parallel operation of several motors set menu 19 for 0.

NOTE: If the set value for start compensation is too high the frequency converter will work in the current limit and then trip out.

Menu 20

Slip compensation [%]

Setting range 0 to 200.

The recorded value is in % of the nominal value.

Must only be set if the speed is unstable and if the load is varying.

Set menu 20 for 0 at parallel operation of several motors.

Menu 21

Voltage frequency ratio [V/Hz]

Setting range 0 to 20.

Must only be set in special cases. See introduction to "Motor compensations".

Menu 42

Motor magnetising current [A].

Used for motor compensation and torque display

The setting must only be changed if the the motor cannot be compensated correctly. If the set value is too low the output frequency will typically increase when the motor load is reduced at low frequencies.

Fault indication

Display fault indications

Menu 80-99 and an applicable data value is recorded when the frequency converter registers a fault.

The menu shows the registered fault.

The data value indicates what the frequency converter has done and what to do to start the motor again.

Menu 80

Current limit

Data value:

00: The frequency is regulated down

01: The frequency is regulated down to 0 Hz. Reset occurs automatically or manually (see menu 30).

The fault can be caused by:

- an overloaded or stalled motor
- a ramp time that is too short.
- start voltage set too high.
- start compensation set too high

Menu 81

Overvoltage

Data value:

00: Ramp operation stops

11: Inverter stop.

Reset either automatically or manually (see menu 30).

12: Inverter stop. Reset manually.

The fault can be caused by:

- over voltage at the supply mains
- ramp down time too short
- regenerative operation
- If brake option is used: set menu 05 between 100-106

Menu 82

Undervoltage

Data value:

00: Warning.

11: Inverter stop.

Reset either automatically or manually (see menu 30).

12: Inverter stop.

Reset manually

The fault can be caused by:

- under voltage on the supply mains
- voltage drop on the supply mains

Menu 83

Internal voltage monitoring.

Data value:

11: Inverter stop.

Reset either automatically or manually (see menu 30).

12: Inverter stop. Reset manually.

The fault is caused by

- defective frequency converter

Menu 84

Inverter overload.

Data value:

02: Cut out due to high motor current for longer than permitted. Reset manually.

11: Inverter stop. Reset either automatically or manually (see menu 30).

12: Inverter stop. Reset manually.

The fault can be caused by:

- motor short circuiting
 - earthing
 - too short ramp up time
 - thermal overloaded of the frequency converter
 - other faults in the power section.
- Warning: Interrupt always the supply voltage after short-circuit, earthing or thermal overload cut-out.

Menu 85

Thermal motor protection.

Data value:

00: Warning of high motor temperature

02: Trip because of too high motor temperature. Reset manually.

Menu 86

Indication of motor current and motor torque is cancelled if the output frequency exceeds 120 Hz.

Menu 99

Unit fault.

- 1: Check if the current supply to the external function is overloaded (terminals 50 and 12)
- 2: Defective control card. Call service.

No light in display

The fault can be caused by:

- Missing phase
- Undervoltage

DANFOSS
C173H05 1.3

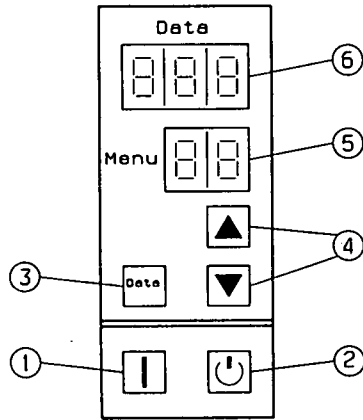

1

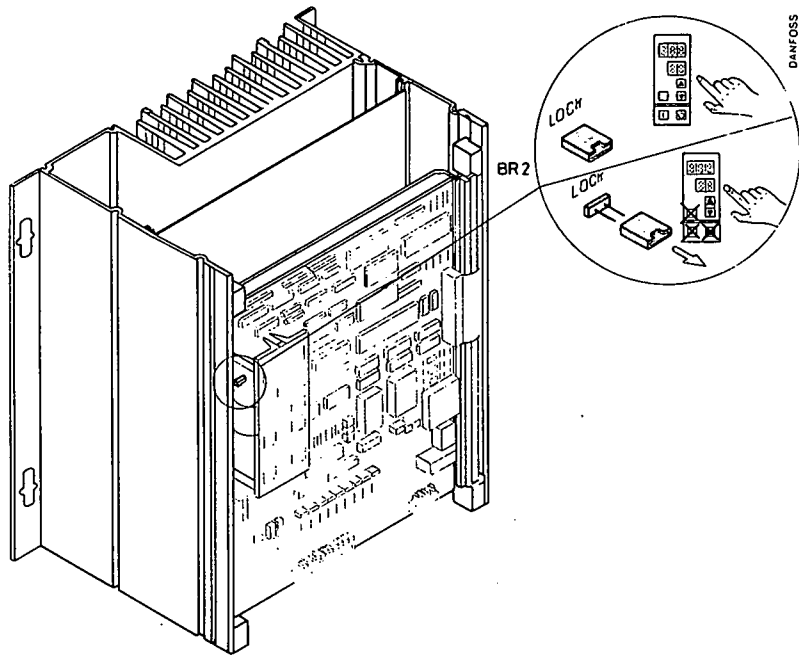

2

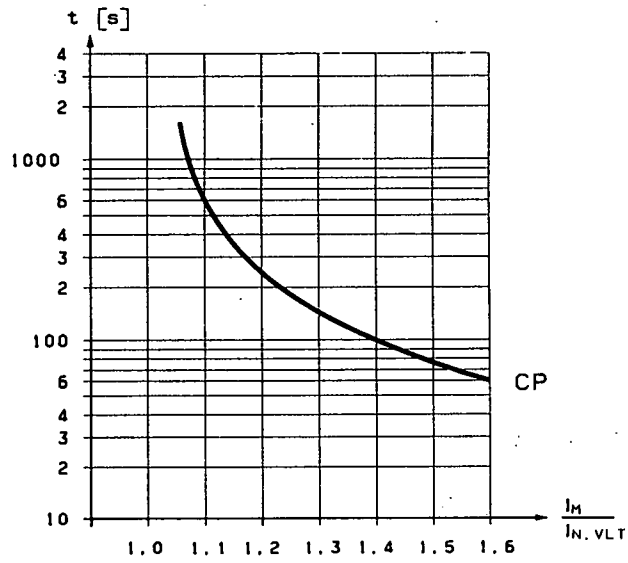

DANFOSS
C175H92 13

1

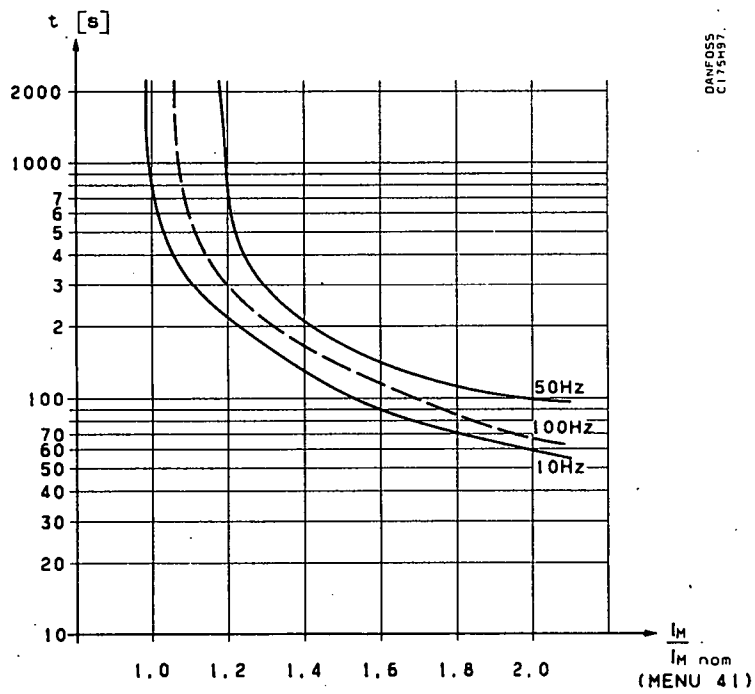

DANFOSS
C175H92

2

MENU 22

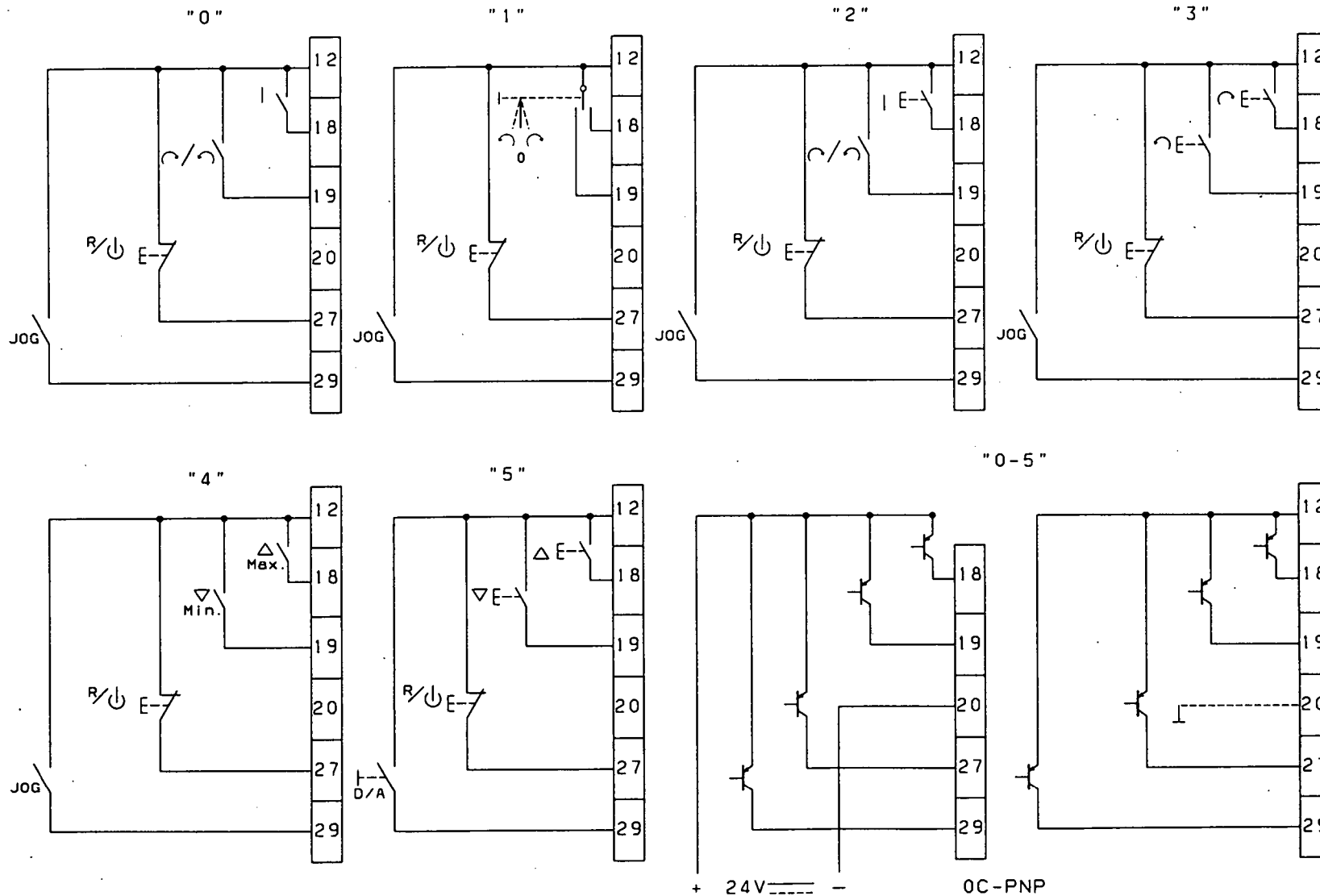

CONFOSSE C175R153. 11

MENU 23

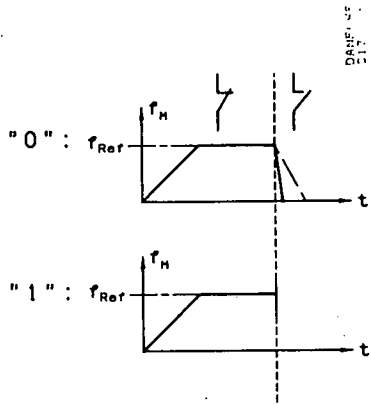
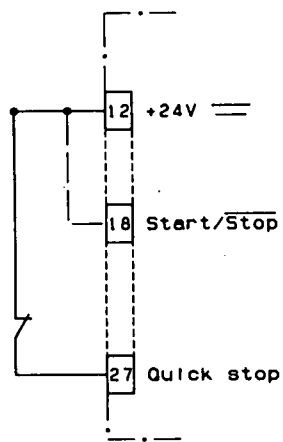

DANFOSS
CITISHEN

1

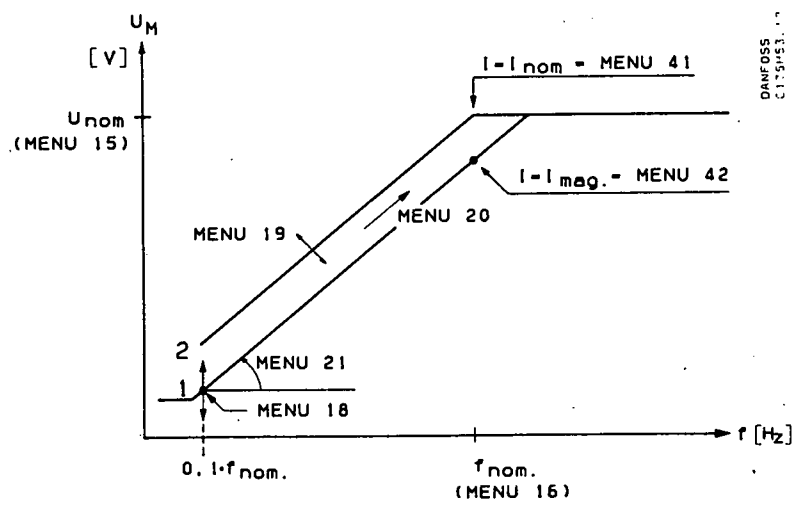

DANFOSS
CITISHEN

2

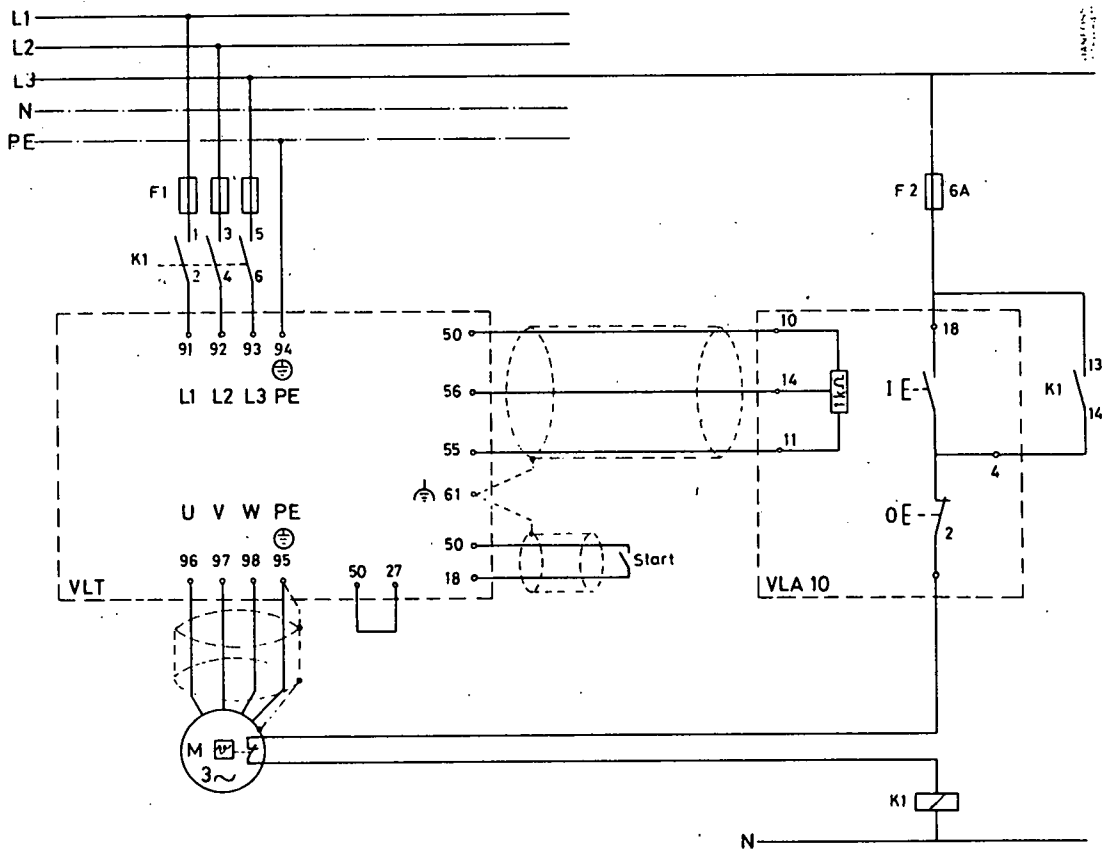

1 Analog VLA 10 control

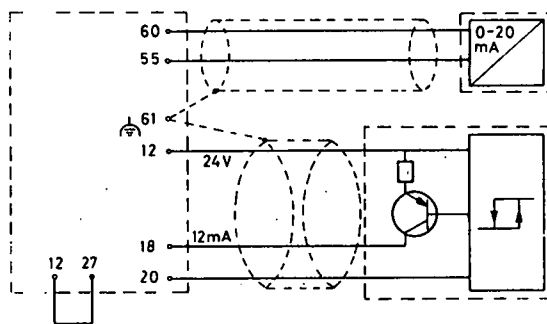

2 PLC control with internal supply

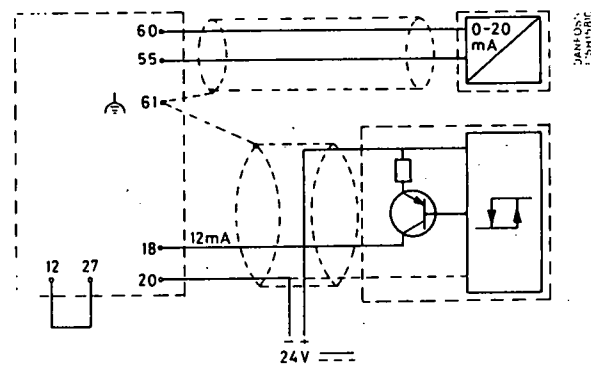

3 PLC control with external supply

Menu outline	380 V / 415 V Typical value	200 V / 230 V Typical value	NOTES
00 Application rate	-	-	
01 Frequency [Hz]	-	-	
02 Voltage [V]	-	-	
03 Current [A]	-	-	
04 Torque [%]	-	-	
05 Basic set up	1	1	
06 Local / remote (0/1)	1	1	
07 Local reference [Hz]	-	-	
08 Min. Speed [Hz]	0.0	0.0	15 Hz
09 Max. Speed [Hz]	50.0	50.0	50 Hz
10 Jogging speed [Hz]	10.0	10.0	
11 Ramp time up [s]	1.0	1.0	
12 Ramp time down [s]	1.0	1.0	
13 Current limit [A]	3.5/ 6.6/ 9.0/ 16.0	6.7/ 12.5/ 17.0	
14 Motor power [kW]	0.75/ 1.5/ 2.2/ 4.0	0.75/ 1.5/ 2.2	2,2
15 Motor nominal voltage [V]	380	200	380
16 Motor nominal frequency [Hz]	50	50	50-60
17 Application rate factor	100	100	
18 Start voltage [V]	42.1/41.1/38.7/37.5	22.0/ 22.2/ 19.3	
19 Start compensation [V/A]	16.0/ 5.0/ 5.0/ 2.3	4.2/ 2.19/ 1.86	
20 Slip compensation [%]	100	100	
21 U/f - ratio [V/Hz]	6.8/ 6.9/ 7.0 /7.1	3.7/ 3.7/ 3.8	
22 Start / stop mode + " ▲ ▼ "	0	0	
23 Digital input select	1	1	
24 Analog input select	0	0	
25 Relay output select + ext. sum	7	7	
27 Analog output (current/frequency)	2	2	
29 Thermal motor protection	1	1	
30 Trip reset mode	0	0	
34 DC braking time [s]	0	0	
40 Restore factory settings	-	-	
41 Motor nominal current [A]	2.0/ 3.7/ 5.3/ 9.1	3.8/ 7.8/ 10.0	
42 Motor magnetization current [A]	1.1/ 2.0/ 2.4/ 3.6	2.0/ 3.2/ 4.6	
80-99 Fault indications	-	-	

NOTE : The values refer to the VLT® types : 3002/ 3003/ 3004/ 3006 3002 / 3003 / 3004 respectively

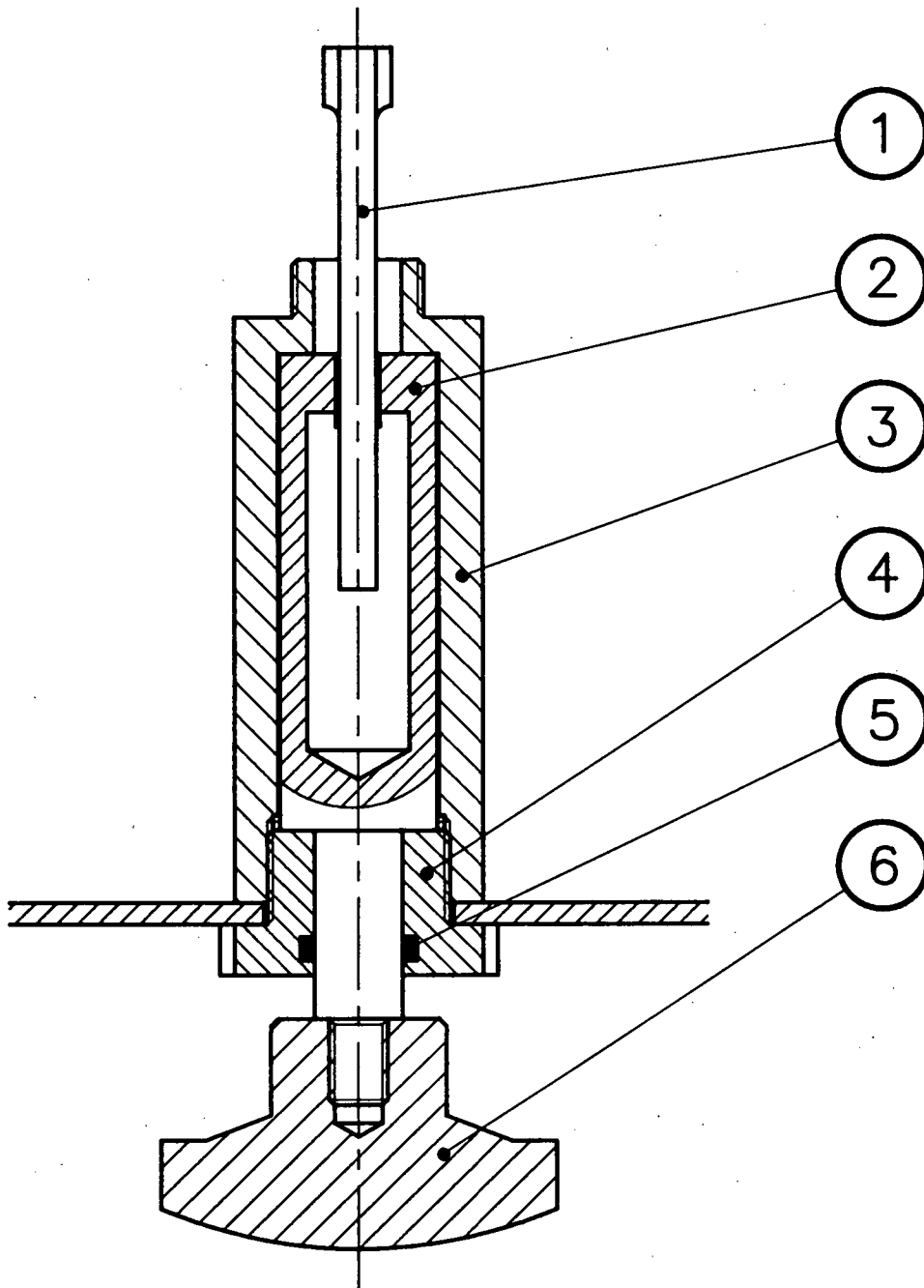

Tolerancer ifølge DS 2075, hvor intet andet er angivet.		Antal	Stykklistenr.	Maskine	Evt. bem.	
Afkortningsmål:		TECHNOHOY CARL HOYER A/S AARHUS - DENMARK			Skala	Tegn. NB
Antal	Dimension				1:1	Dato
		Regulation KVP - Valve, DANFOSS			 	
		D 16328				

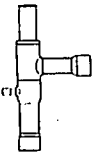

KVP, KVL, KVR

034R9631

034R9631

R 12, R 22, R 502

KVP: $p_e = 0 \rightarrow 5.5 \text{ bar}$ (0 \rightarrow 80 psig)
 KVL: $p_e = 0.5 \rightarrow 6 \text{ bar}$ (7 \rightarrow 87 psig)

KVR 12, 15, 22: $p_e = 5 \rightarrow 20 \text{ bar}$ (72 \rightarrow 290 psig)
 KVR 28, 35: $p_e = 5 \rightarrow 17.5 \text{ bar}$ (72 \rightarrow 240 psig)

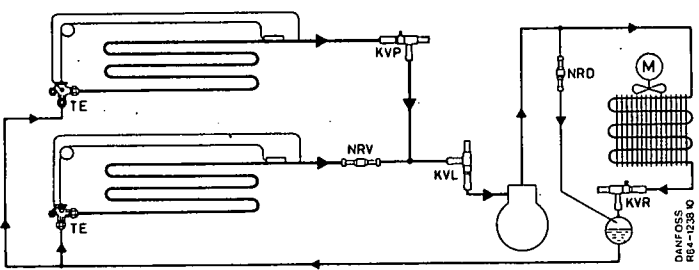
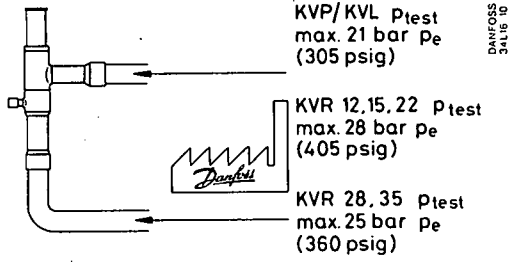
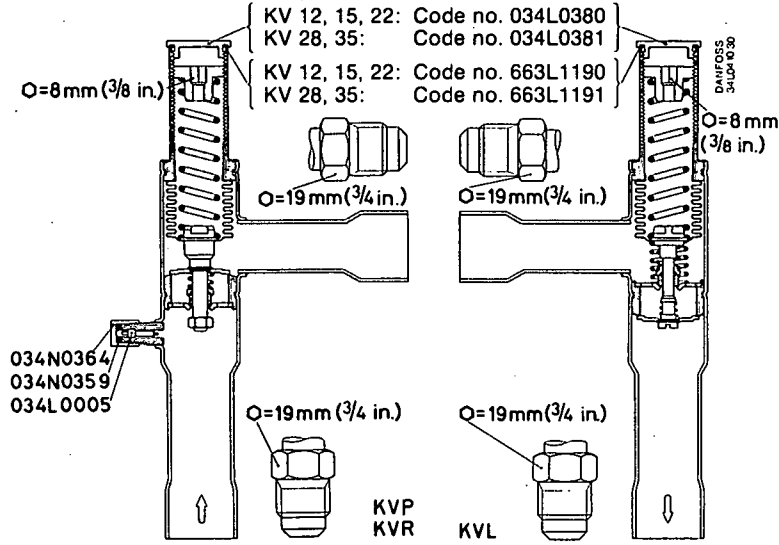

KVP, KVL:
 $t_{max.}$ (R 12, R 22, R 502) = +60°C (140°F)
 $t_{min.}$ (R 12, R 22, R 502) = -45°C (-50°F)
 $p_{working max.}$ = 14 bar p_e (205 psig)

KVR:
 $t_{max.}$ (R 12, R 22, R 502) = +105°C (220°F)
 $t_{min.}$ (R 12, R 22, R 502) = -45°C (-50°F)

KVR 12, 15, 22:
 $p_{working max.}$ = 21.5 bar p_e (312 psig)

KVR 28, 35:
 $p_{working max.}$ = 19.3 bar p_e (280 psig)

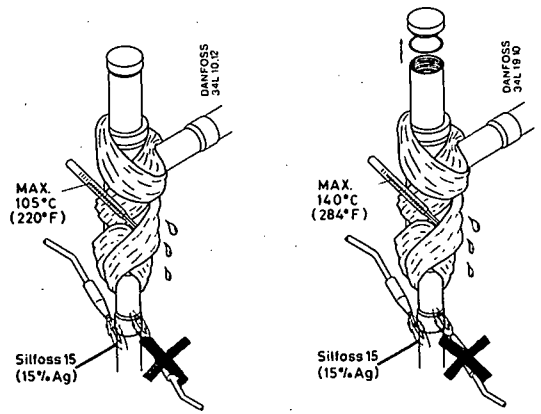

KVP, KVL, KVR

KVL

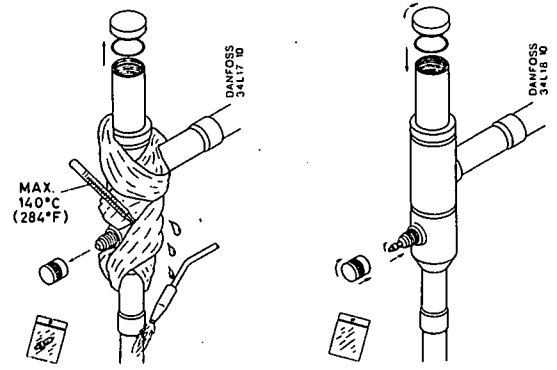

KVP, KVR

KVP, KVR

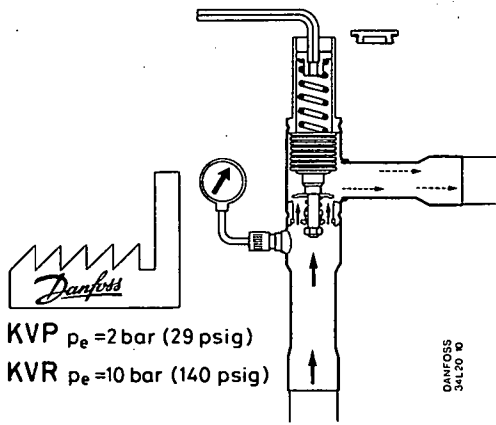

KVP $p_e=2$ bar (29 psig)
 KVR $p_e=10$ bar (140 psig)

DANFOSS
 34L20 10

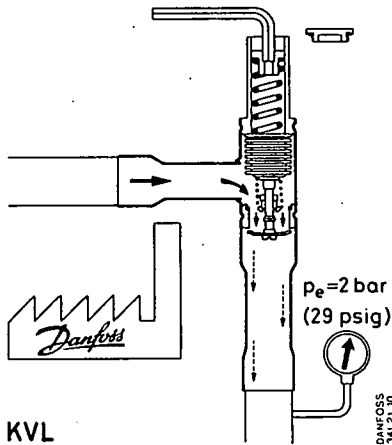

KVL

DANFOSS
 34L17 10

360°

KVP/KVL 12,15,22 ~ 0.45 bar (6 psi)
 28,35 ~ 0.3 bar (4 psi)

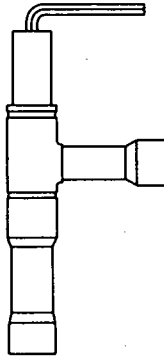

KVR 12,15,22

	72	108	145	181	218	253	290
	5	7.5	10	12.5	15	17.5	20
360° x 2	1	0	1	2	3	4	5

R 12 22 35 46 54 62 69 75 °C

72 95 115 129 144 156 167 °F

R 22 6 18 27 35 42 48 53 °C

43 64 81 95 108 118 127 °F

R 502 2 14 23 31 38 44 50 °C

36 57 73 88 100 111 122 °C

KVR 28,35

	80	102	123	145	166	188	210	232	253
	5.5	7	8.5	10	11.5	13	14.5	16	17.5
360° x 3	2	1	0	1	2	3	4	5	6

R 12 25 33 40 46 51 56 61 65 69 °C

77 91 104 115 124 133 142 149 156 °F

R 22 8 15 22 27 32 36 40 44 48 °C

46 59 72 81 90 97 104 111 118 °F

R 502 4 11 18 23 28 32 37 41 44 °C

39 52 64 73 82 90 99 106 111 °F

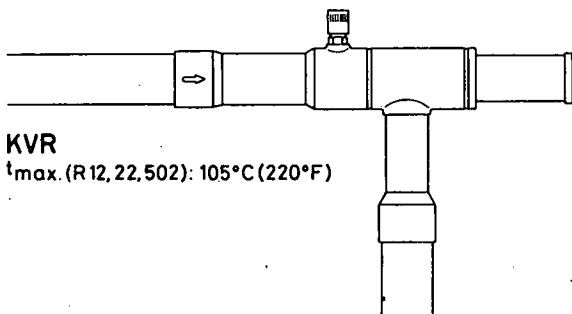

KVR
 $t_{max.}$ (R12, 22, 502): 105°C (220°F)

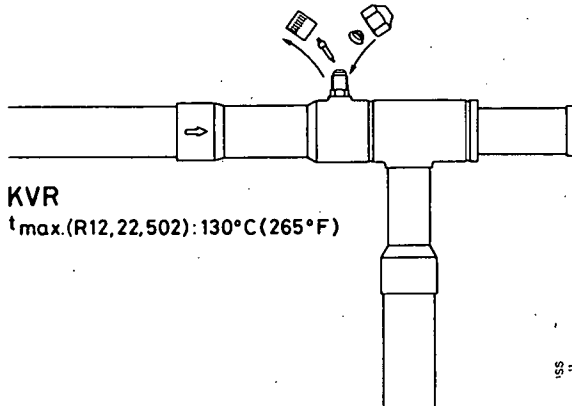

KVR
 $t_{max.}$ (R12, 22, 502): 130°C (265°F)

ISS
 11

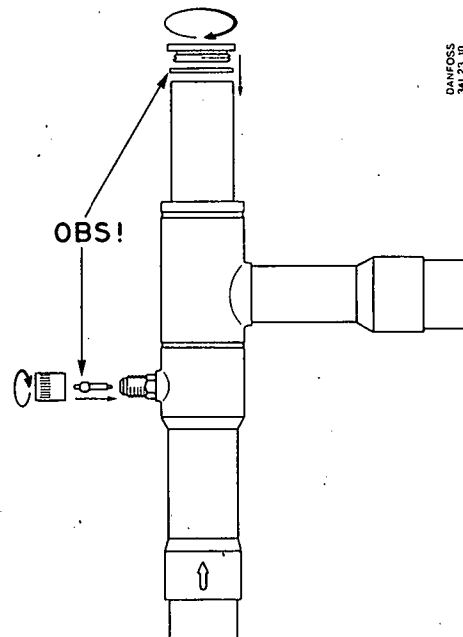

DANFOSS
 34L20 10

KVP, KVR

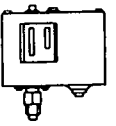

60R9512

KP 5: R 12, R 22, R 500, R 502

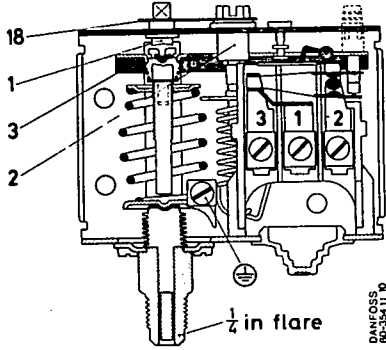

Fig. 1
KP 5

KP 5A: R 717 (NH₃), R 12, R 22, R 500, R 502

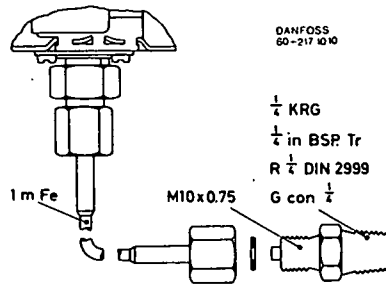

Fig. 2
KP 5A

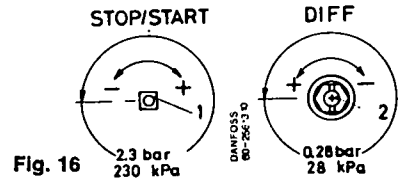
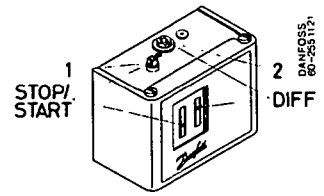

Fig. 16

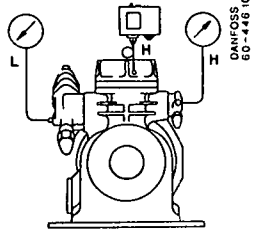

Fig. 4

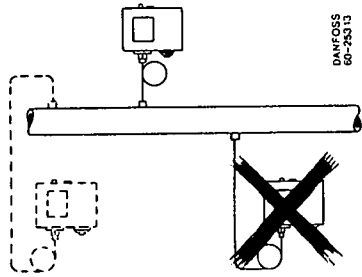

Fig. 4

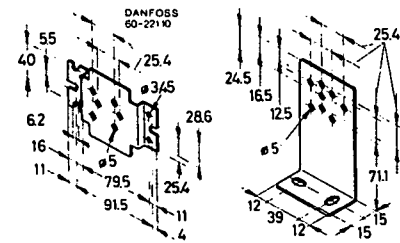

Fig. 5 60-1055 60-1056

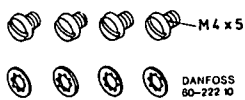

Fig. 6 60-1054



Fig. 8

Fig. 9

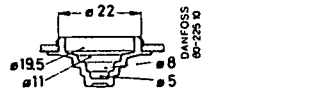

Fig. 10

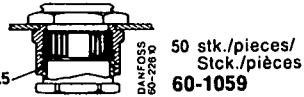

Fig. 11



Fig. 12

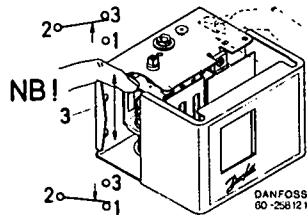

Fig. 13

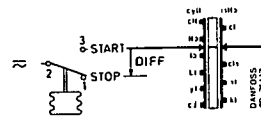

Fig. 14a

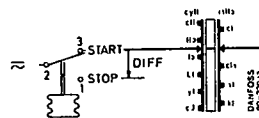

Fig. 14b

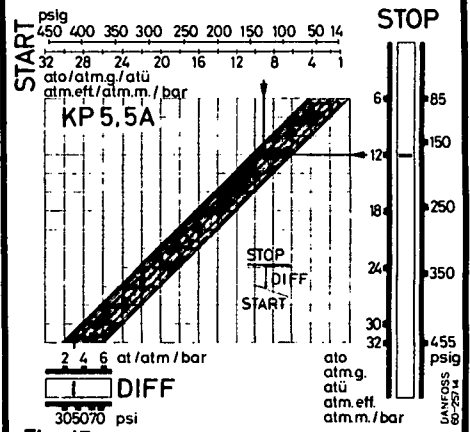

Fig. 17

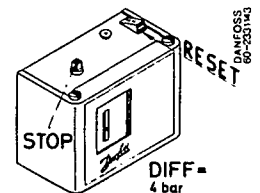

Fig. 18

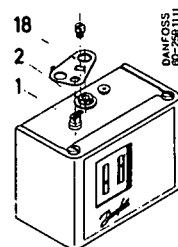

Fig. 19

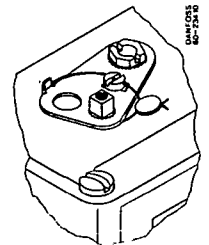

Fig. 20

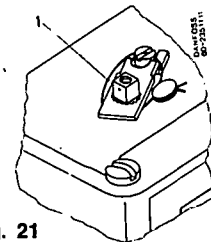

Fig. 21



Fig. 22

60R9512

Højtrykspressostater

Fig. 1. KP 5 med flare-tilslutning

1. Områdespindel
2. Differensspindel
3. Hovedarm
18. Låseplade

Fig. 2. KP 5A tilslutning

Funktion

Kontakterne 2-1 bryder, og 2-3 slutter ved stigende tryk. Se fig. 8 og 9.

Tekniske data

Tilladelig omgivelsestemp.

-40 til +65°C (+80°C i max. 2 timer)

Max. till. prøvningstryk

$p_n = 33$ bar

Kapsling og tæthed

1 henhold til IEC 144 og DIN 40050:

IP 44 (SEV)

Det er en forudsætning, at apparatet er monteret på en plan tavle eller på en konsol. Apparatet skal placeres således på konsollen, at alle frihuller er dækket.

Kontaktbelastning

Se apparatets skala.

Max. startstrøm = 112A 380 V.

Montering

Fig 3 og 4. Korrekt montering.

NB! Hold kontra på tilslutningsstudsene, når flare-omløberen spændes eller løsnes!

Fig. 5. 2 typer monteringskonsoller med skruer og skiver. Bestilles separat.

Fig. 6. 4 stk. ekstra skruer og skiver. Anvendes ved montering på eksisterende konsol. Bestilles separat.

NB! Anvendes der eventuelt andre skruer, sørg da for, at de ikke stikker mere end 1,5 mm ind i apparatet.

El-tilslutning

Fig. 8 og 9. Alt efter den valgte funktion foretages tilslutning til klemmerne 2-1 eller 2-3.

Fig. 10. Kabelgennemføring af plast. Kan anvendes ved 6-14 mm kabel.

Fig. 11. Pg 13,5 kabelforskrumning med spec. møtrik. Bestilles separat. Kan anvendes ved 6-14 mm kabel. Ved 8-16 mm kabel kan anvendes en standard kabelforskrumning.

Fig. 12. Ekstra møtrik til Pg 13,5 kabelforskrumning. Bestilles separat.

Afprøvning

Fig. 13. Hovedarmen (3) vippes.

Ved afprøvning af reset-apparater skal »RESET«-knappen påvirkes, samtidig med at hovedarmen (3) vippes.

NB! Benyt kun den viste metode ved afprøvning!

Indstilling

Fig. 14.

»START« = starttryk

»STOP« = stoptryk

»DIFF« = differens

Alt efter den valgte funktion og klemmetilslutning indstilles stop- eller starttrykket på områdeskalaen.

Apparater uden reset

Fig. 15 og 16. Eksempel: Kompressormotoren ønskes stoppet ved stigende tryk (højtrykssikring). Indstil stoptrykket på »STOP«-skalaen. En omdrejning af områdespindelen (1) ~ 2,3 bar.

Differensen = stoptrykket minus starttrykket.

Indstil differensen på »DIFF«-skalaen.

En omdrejning af differensspindelen (2) ~ 0,28 bar.

Kontroller start- og stoptrykket med manometer!

Fig. 17. Eksempel på indstilling af KP 5 uden reset.

Ønsket stoptryk = 12 bar

Ønsket starttryk = 9 bar

Differensen bliver $12 - 9 = 3$ bar

Stoptrykket = 12 bar indstilles på »STOP«-skalaen.

Differensen = 3 bar indstilles på »DIFF«-skalaen.

Kompressormotoren/styrestrømmen tilsluttes klemme 1. Fasen tilsluttes klemme 2. Se fig. 9 og 14.

Apparater med max. reset

Fig. 18. Indstil stoptrykket på »STOP«-skalaen. Differensen er fast indstillet til 3 bar. Kompressormotoren genstartes efter stop ved at trykke på »RESET«-knappen. Genstart kan først ske, når trykket er faldet ca. 3 bar under det indstillede stoptryk.

Låsning af indstillingen

Apparater uden reset

Fig. 19. Områdespindelen (1) og differensspindelen (2) kan låses med låsepladen (18).

Fig. 20. Ønskes plombering, anvendes plombeskruer. Se fig. 22.

Apparater med max. reset

Fig. 21. Områdespindelen (1) kan låses med den medleverede låseplade.

Fig. 22. Plombeskruer. Bestilles separat.

ENGLISH

High-pressure controls

KP 1, KP 5 with flare connection

1. Range setting spindle
2. Differential setting spindle
3. Main arm
18. Locking plate

Fig. 2. KP 5A connection

Function

Contacts 2-1 break and contacts 2-3 make at a rise in pressure. See fig. 8 and 9.

Technical data

Permissible ambient temperature
-40 to +65°C (-40 to +150°F); +80°C (+176°F) for maximum 2 hours

Maximum permissible test pressure

$p_e = 33$ bar (470 psig)

Enclosure and tightness

In accordance with IEC 144 and DIN 40050: IP 44 (SEV).

It is a condition that the unit is mounted on a plain board or on a bracket. The unit shall be placed on the bracket in such a way that all open holes are covered.

Rating

See dial on unit.

Max. starting current = 112A 380 V.

Fitting

Fig. 3 and 4. Correct fitting.

NOTE: Keep a counter grip with a spanner on the connector during tightening or slackening of the flared coupling nut!

Fig. 5. Two types of mounting bracket with screws and washers. To be ordered separately.

Fig. 6. Four extra screws and washers. To be used for mounting on the existing bracket. To be ordered separately.

NOTE! If other screws are used, take care that these do not project more than 1.5 mm into the control.

Mains connection

Fig. 8 and 9. Depending on the function chosen connection is made to terminals 2-1 or 2-3.

Fig. 10. Plastic cable entry. Can be used for 6-14 mm cable.

Fig. 11. Pg 13.5 screwed cable connection with special nut. To be ordered separately. Can be used for 6-14 mm cable. A standard screwed cable connection can be used for 8-16 mm cable.

Fig. 12. Extra nut for 13.5 screwed cable entry. To be ordered separately.

Testing

Fig. 13. Tilt the main arm (3).

To test controls with reset, the "RESET" button should be actuated, the main arm (3) being tilted at the same time.

NOTE: Only the method shown should be used for testing!

Setting

Fig. 14.

"START" = start pressure

"STOP" = stop pressure

"DIFF" = differential

Depending on the function chosen and the terminal connections, the stop or start pressure is set on the range scale.

Unit without reset

Fig. 15 and 16. Example: It is desired to stop the compressor motor at a rise in pressure. (High pressure safeguard). Set the stop pressure on the "STOP" scale. One turn of the range spindle (1) ~ 2.3 bar.

The differential = the stop pressure minus the start pressure.

Set the differential on the "DIFF" scale. One turn of the differential spindle (2) ~ 0.28 bar.

Check the start and stop pressure with a gauge.

Fig. 17. Example of setting KP 5 without reset

Stopping pressure required = 12 bar (171 psig)

Starting pressure required = 9 bar (128 psig)

The differential will be $12 - 9 = 3$ bar (171 - 128 = 43 psi).

The stopping pressure = 12 bar (171 psig) is set on the "STOP" scale.

The differential = 3 bar (43 psi) is set on the "DIFF" scale.

The compressor motor/pilot current is connected to terminal 1.

Phase is connected to terminal 2. See Figs. 9 and 14.

Controls with maximum reset

Fig. 18. Set the stopping pressure on the »STOP« scale. The differential is fixed at 3 bar (43 psi). The compressor motor is restarted after stopping by depressing the »RESET« button. Restarting cannot be done until the pressure has decreased to approx. 3 bar (43 psi) below the set stopping pressure.

Locking the setting

Units without reset

Fig. 19. The range setting spindle (1) and differential setting spindle (2) can be locked by means of the locking plate (18).

Fig. 20. If sealing with wire and lead is required, use the sealing screw. See fig. 22.

Units with max. reset

Fig. 21. The range setting spindle (1) can be locked with the aid of the locking plates supplied.

Fig. 22. Sealing screw. Order separately.

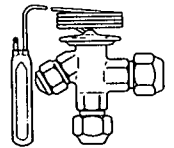

068R9633

068R9633

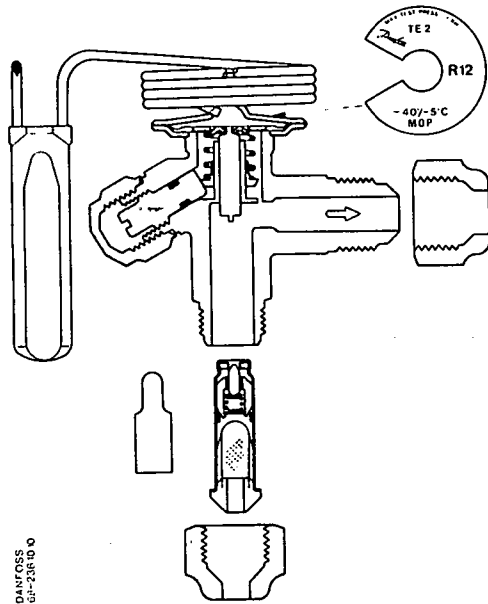

- N = -40 → +10°C (-40 → +50°F)
- B = -60 → -25°C (-75 → -15°F)
- N = -40 → +10°C (-40 → +50°F) MOP ~ +15°C (+60°F)
- NM = -40 → -5°C (-40 → +25°F) MOP ~ 0°C (+32°F)
- NL = -40 → -15°C (-40 → +5°F) MOP ~ -10°C (+15°F)
- B = -60 → -25°C (-75 → -15°F) MOP ~ -20°C (-5°F)

				Nr.	kW (kJ/s)	kcal/h	TR (tons)
N NM NL	T 2 TE 2	R 12 R 502	No. 1	68-2004	1.0	900	0.3
			No. 2	68-2005	1.7	1500	0.5
			No. 3	68-2006	3.5	3000	1.0
			No. 4	68-2007	5.2	4500	1.5
			No. 5	68-2008	7.0	6000	2.0
			No. 6	68-2009	10.5	9000	3.0
	T 2 TE 2	R 22	No. 1	68-2004	1.7	1500	0.5
			No. 2	68-2005	2.8	2400	0.8
			No. 3	68-2006	5.2	4500	1.5
			No. 4	68-2007	8.0	6900	2.3
			No. 5	68-2008	10.5	9000	3.0
			No. 6	68-2009	15.7	13500	4.5
B	T 2 TE 2	R 22 R 502	No. 1	68-2004	1.0	900	0.3
			No. 2	68-2005	1.7	1500	0.5
			No. 3	68-2006	2.8	2400	0.8
			No. 4	68-2007	4.2	3600	1.2
			No. 5	68-2008	5.2	4500	1.5
			No. 6	68-2009	7.0	6000	2.0

N/NM/NL: $t_o = +5^\circ\text{C}$, $t_k = +32^\circ\text{C}$
 $(t_o = +40^\circ\text{F}$, $t_k = +90^\circ\text{F})$
 B: $t_o = -30^\circ\text{C}$, $t_k = +32^\circ\text{C}$
 $(t_o = -22^\circ\text{F}$, $t_k = +90^\circ\text{F})$

TE 2

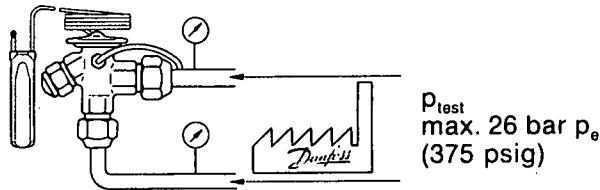

T 2

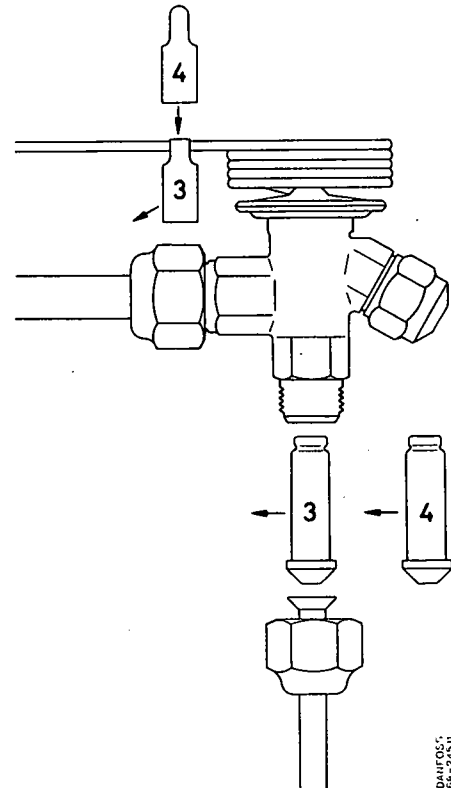
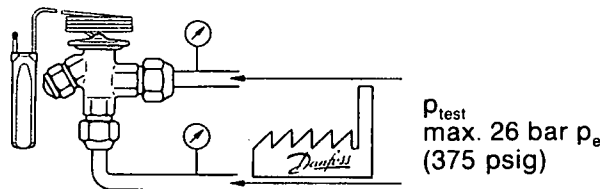

T/TE 2

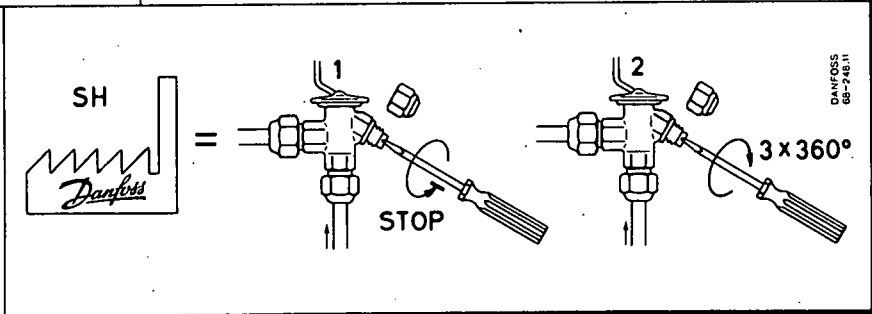
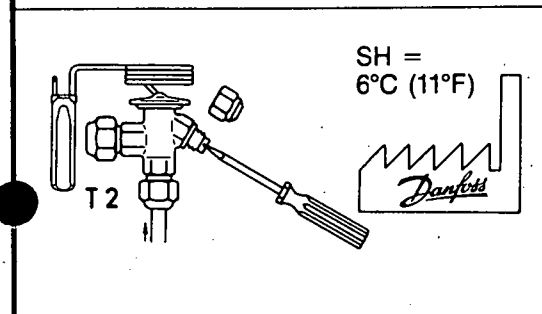
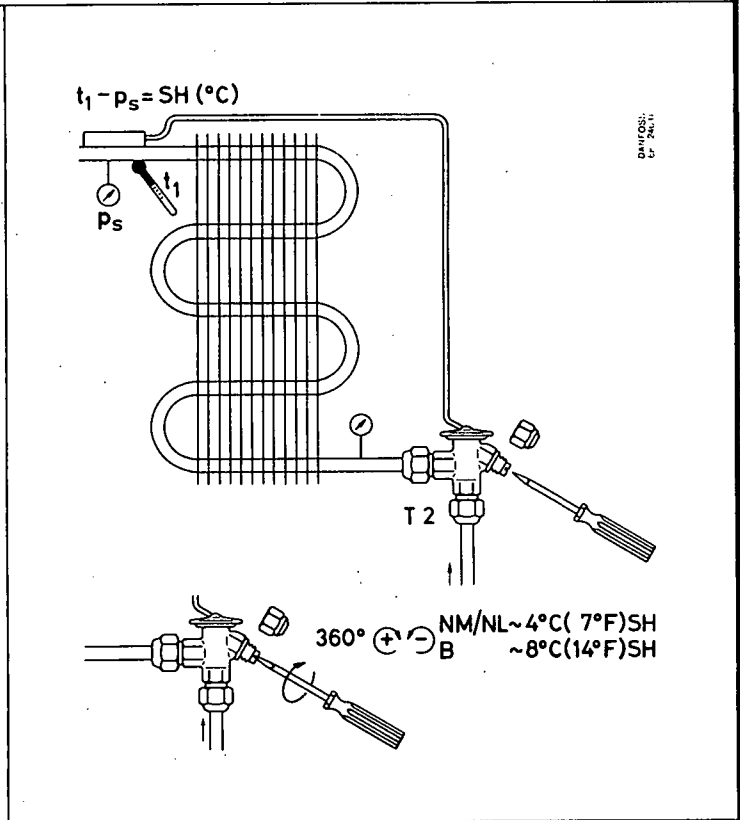
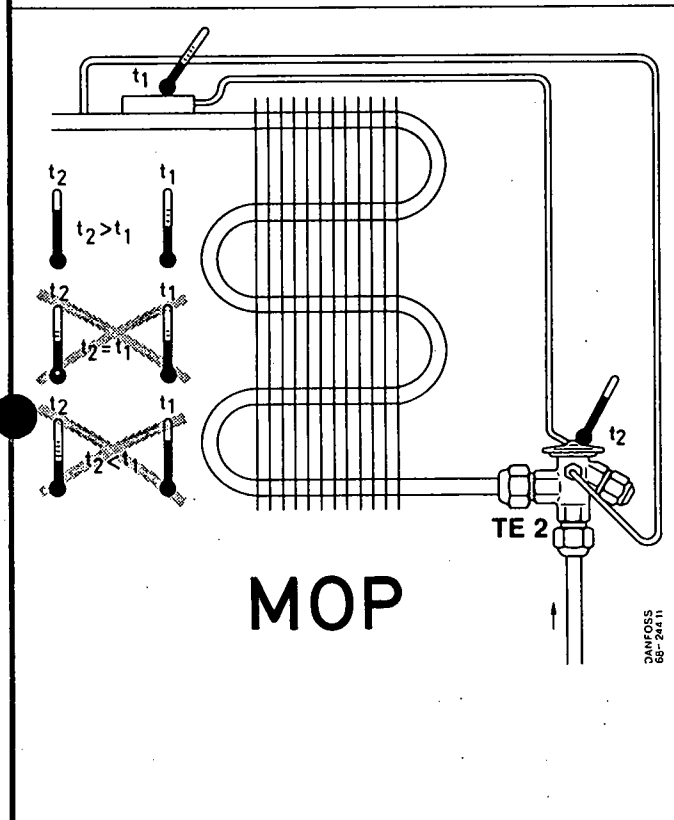
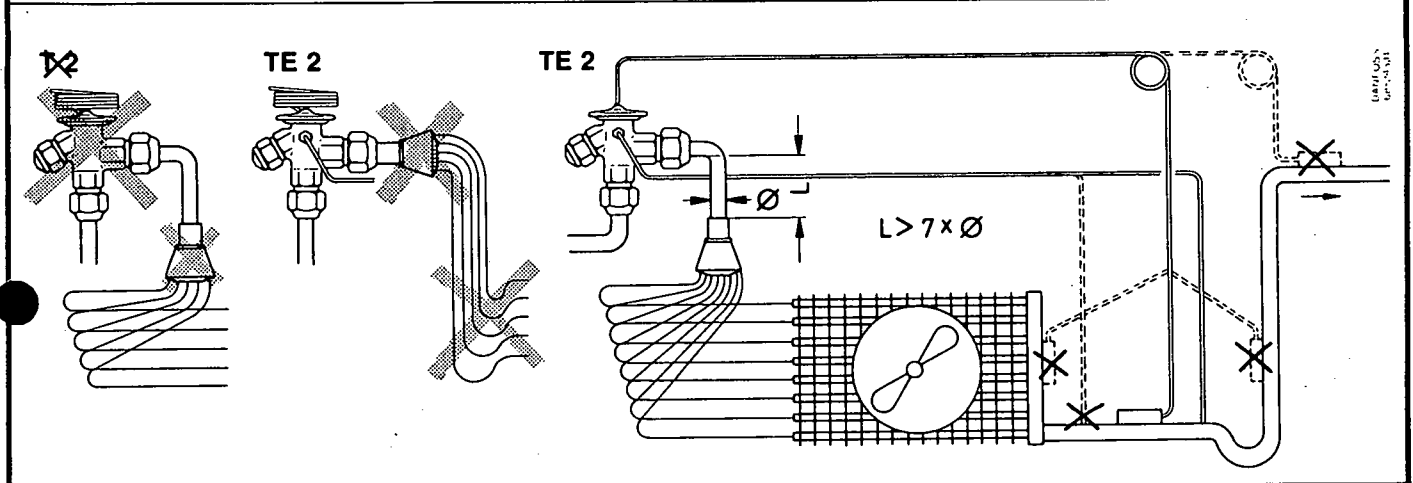
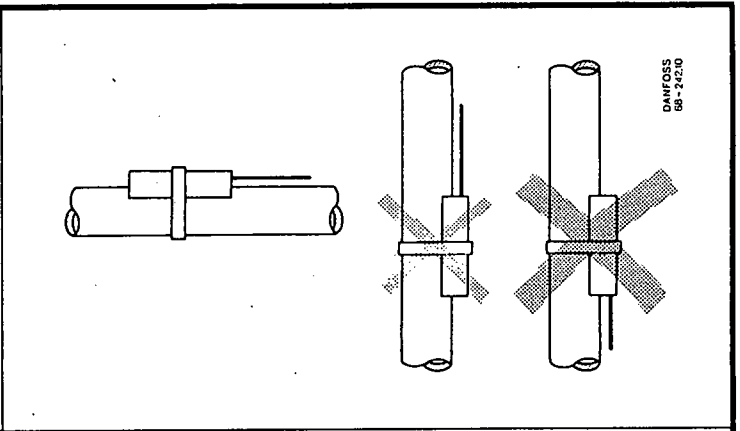
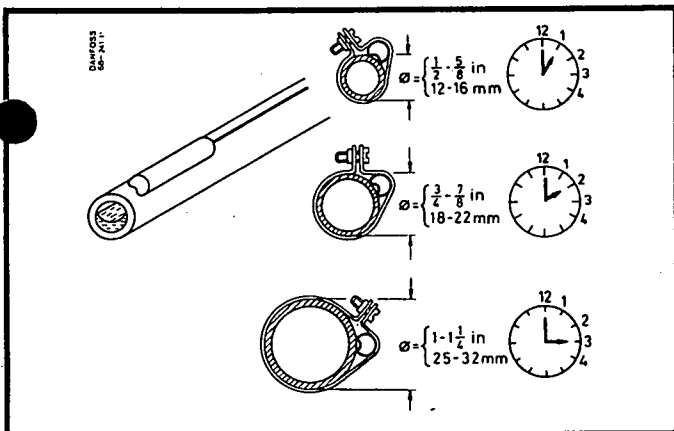

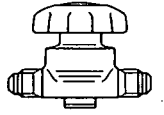

009R9663

009R9663

R 12, R 22, R 500, R 502

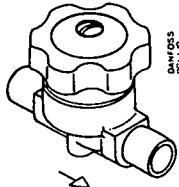

DANFOSS
BM 1.0

Fig. 1

BML

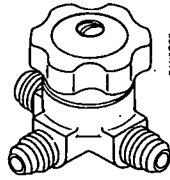

DANFOSS
BM 1.0

BMT

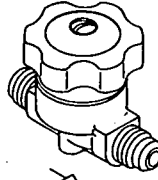

DANFOSS
BM 1.0

BML

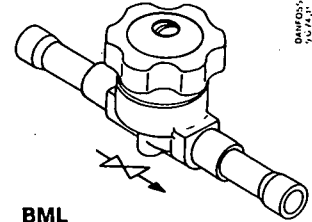

DANFOSS
BM 1.0

BML

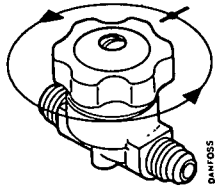

DANFOSS
BM 1.0

Min. medium temperature: -55°C (-70°F)
 Max. medium temperature: 100°C (210°F)
 Min. working pressure: -1 bar/30 in Hg
 PB = 21.5 bar / MWP = 310 psig

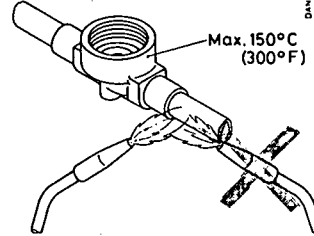
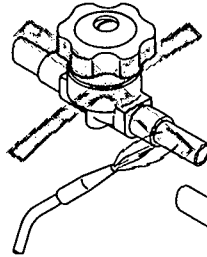

Fig. 2

Max. 150°C
(300°F)

Max. 150°C
(300°F)

Max. 700°C
(1300°F)

DANFOSS
BM 1.0

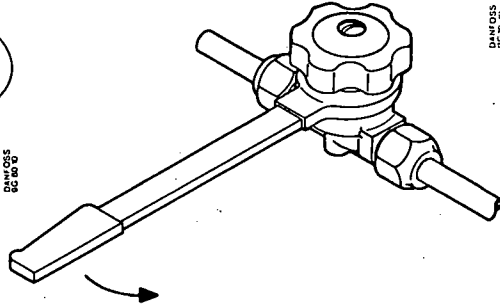
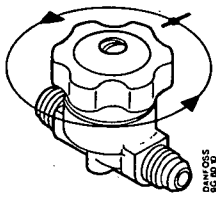

DANFOSS
9G78.10

 DANFOSS 9G78.10	
BM 6	9G0025
BM 10	9G0026
BM 12	9G0027
BM 15	9G0028
BM 18-22	9G0029

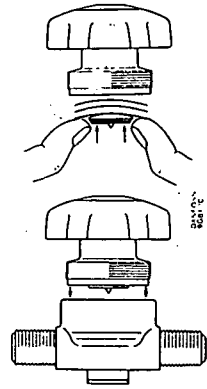

DANFOSS
9G78.10

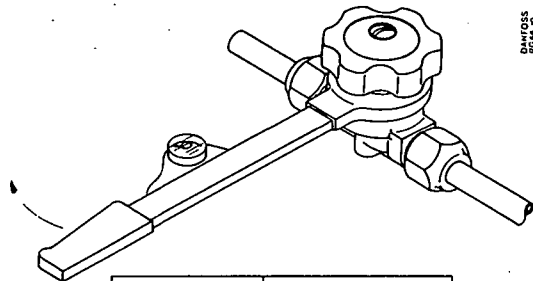

DANFOSS
9G78.10

BM 6-10	50 Nm (5 kpm)
BM 12	60 Nm (6 kpm)
BM 15-22	80 Nm (8 kpm)

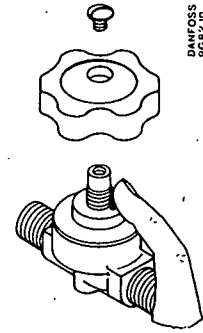
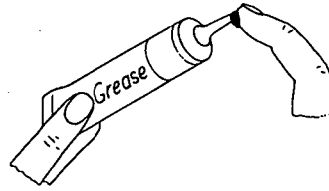

DANFOSS
9G78.10

23A0450

23A0450

DX – solid core:
R 12, R 22, R 500, R 502

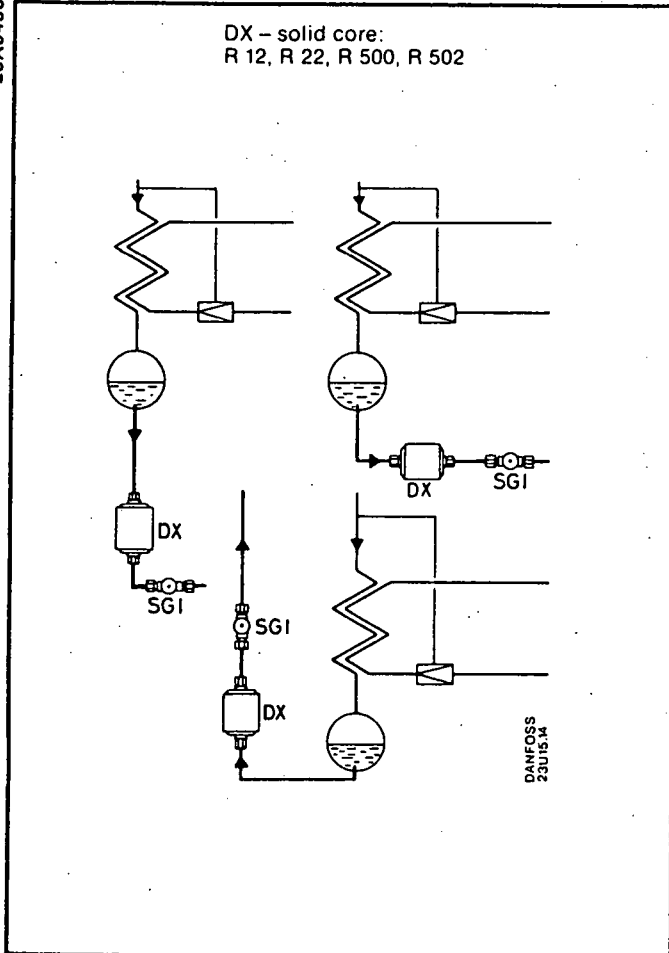

DAN7A-1

KL 5-66-00 → RI.10.G1.00 4-1983

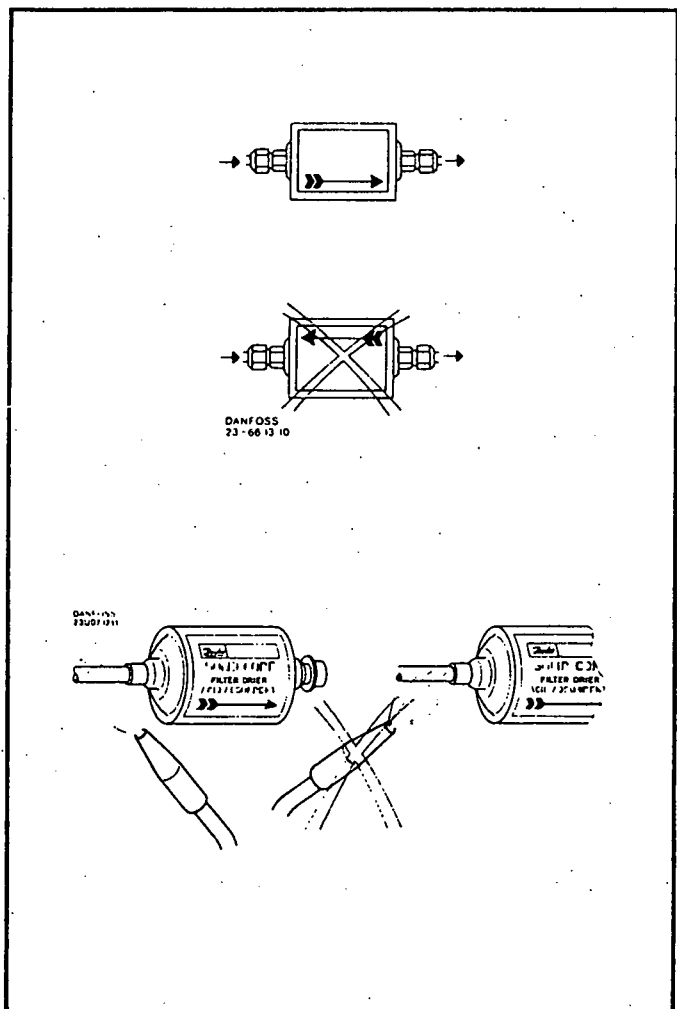

DAN7A-2

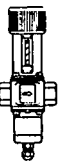

3N0481

3N0481

RESERVEDELE/SPARE PARTS/ERSATZTEILE/PIÈCES DE RECHANGE/
ONDERDELEN/PIEZAS DE REPUESTO/VARAOSAT

No.	WVFX 10-15	WVFX 20	WVFX 25	WVFX 32-40
3a	3N0337	3N0337	3N0338	
5	633B1183	633B1183	633B1183	633B1009
6				3F0507
7	3N0427	3N0428	3N0429	
8	3N0342	3N0343	3N0344	
9	3N0401	3N0401	3N0401	
13	681X2170	681X2170	681X2170	681X1119
14	3N0348	3N0369	3N0370	
14a	3N0345	3N0346	3N0347	
22				3F0508
29	681X1089	681X1089	681X1089	681X1119

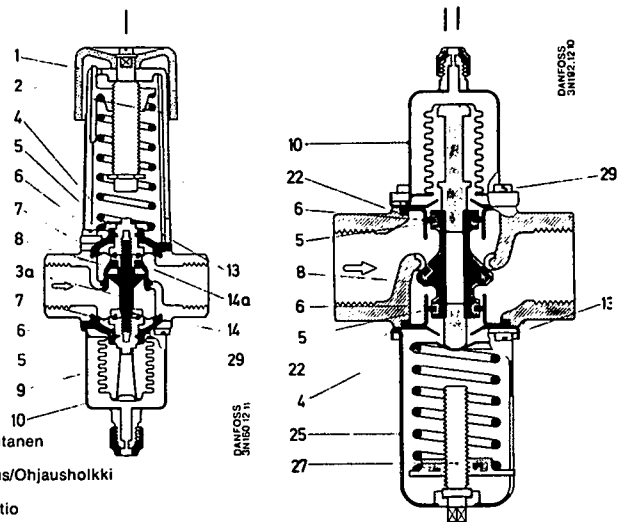

1. Håndhjul/Hand wheel/Handrad/Roue à main/Volante manual/Handwiel/Asettelukahva
2. Overpart/Top part/Oberteil/Partie supérieure/Parte superior/Bovendeel/Yläosa
- 3a. Spindel/Spindel/Spindel/Tige/Vástago/Spindel/Kara
4. Fjederstyr/Spring retainer/Federführung/Guide du ressort/Muelle guía/Veerborging/Jousilautanen
5. O-ring/O-ring/O-Ring/Bague torique/Anillo/O-ring/O-rengas
6. Styrebøsning/Guide bushing/Führungsbuchse/Douille de guidage/Manguito guía/Geleidebus/Ohjausholkki
7. Membran/Diaphragm/Membrane/Membrane/Membrana/Membraan/Kalvo
8. Ventiltægle/Valve cone/Ventiltægel/Cône de la vanne/Cono de cierre/Klepschotel/Venttiilkartio
9. Trykfod/Spring holder/Druckfuss/Pied de pression/Impulsor/Veerhouder/Paineputki
10. Bælgelement/Bellows unit/Wellrohrelement/Élément de soufflet/Fuelle/Balgelement/Paljoesa
13. Skruer for fjederhus/Screw for spring housing/Schraube für Federgehäuse/Vis pour boîtier à ressort/Tuerca para la caja del muelle/Schroef voor veerhuis/Jousikotelon ruuvi
14. Membranskive/Diaphragm plate/Membranscheibe/Disque de membrane/Segmento de la membrana/Membraanplaat/Kalvolevy
- 14a. Spændebøsning/Retaining bushing/Spannhülse/Douille de serrage/Casquillo de retención/Borgbus/Kirstysholkki
22. Pakning for styrebøsning/Guide bushing gland/Dichtung für Führungsbuchse/Joint pour douille de guidage/Empaquetadura para el manguito guía/Packingbus voor geleidebus/Ohjausholkin tiiviste
25. Fjederhus/Spring housing/Federgehäuse/Boîtier du ressort/Cajera del muelle/Veerhuis/Jousikotelo
27. Reguleringspindel/Regulating spindle/Verstellspindel/Tige de réglage/Vástago de regulación/Regelspindel/Säättökara
29. Skruer for bælgkapsel/Screw for bellows housing/Schraube für Wellrohrkapsel/Vis pour cuve contenant le soufflet/Tornillo para la cápsula del fuelle/Schroef voor balghuis/Paljekotelon ruuvi

DANSK

Tekniske data

Max. prøvningstryk (bælgelement): 26,5 bar (p_a)
Max. vandtryk: Udf. I = 16 bar (p_a)
Udf. II = 10 bar (p_a)

Ventilen kan indstilles til at begynde at åbne ved følgende kondenseringstryk
Udf. I: Min. 3,5 bar (p_a). Max. 16 bar (p_a)
Udf. II: Min. 4 bar (p_a). Max. 17 bar (p_a)

Montering

Udf. I kan monteres i vilkårlig stilling. Udf. II monteres altid med bælgelementet opad.
Elementet 10 tilsluttes trykrøret efter olieudskilleren. Forbindelsesrøret tilsluttes oven på trykrøret, så tilbageløb af snavs og olie undgås.
Indskyd desuden et smudsfilter før ventilen.
En konsol (best.nr.: 3N0388) kan ved montering af Udf. I anbringes mellem overpart og ventilhus.

Indstilling

Ventilen indstilles, så det ønskede kondenseringstryk overholdes ved normal drift.
Udf. I: Drejning af 1, så indikatoren går mod »1«, giver lavere tryk og omvendt.
Udf. II: Drejning af 27 højre om (med uret) giver lavere tryk og omvendt.

Service

Snavspartikler kan fjernes fra ventilens indre ved gennemskyllning. En skruetrækker føres gennem åbningen i 2 hhv. 25 ind under fjederstyret 4. Når styret trykkes væk fra ventilhuset, åbner ventilen.
NB.: Bælgelementet 10 må ikke demonteres, medens der er tryk på anlægget. Bælgen kan da blive deformeret.
Før adskillelse aflastes fjederen ved, at ventilen »indstilles« til laveste kondenseringstryk.
Udskift slidte O-ringe, indsmør cylinder og styrebøsning i syrefrit fedtstof og smør skruer/spindel for samling af ventilen.
Udf. I: »RA« på ventilhus skal vende mod 2.

ENGLISH

Technical data

Max. test pressure (bellows unit): 26.5 bar (p_a)
Max. water pressure: Design I = 16 bar (p_a)
Design II = 10 bar (p_a)

The valve can be set to start opening at the following condensing pressures
Design I: Min. 3.5 bar (p_a). Max. 16 bar (p_a)
Design II: Min. 4 bar (p_a). Max. 17 bar (p_a)

Fitting

Design I can be fitted in any position. Design II should always be fitted with the bellows unit facing upwards.
The unit 10 is connected to the pressure line after the oil separator. Fit the connecting pipe on the top of the pressure line to avoid the return of dirt and oil. A strainer should be fitted ahead of the valve.
A bracket (code No. 3N0388) for the installation of design I can be located between the top part and the valve housing.

Setting

Set the valve to maintain the condensing pressure required during normal operation.
Design I: Turning 1 so that the indicator moves towards "1" results in a lower pressure, and vice versa.
Design II: Turning 27 clockwise results in a lower pressure, and vice versa.

Service

Impurities can be removed from the inside of the valve by flushing. Introduce screwdriver under the spring retainer 4 through the openings in 2 and 25, respectively. Forcing the retainer away from the valve housing opens the valve.
NOTE: The bellows unit 10 must not be dismantled while the system is under pressure, since the bellows may become distorted.

The spring should be relieved before dismantling the valve by "setting" the valve for minimum condensing pressure.
Replace worn O-rings, smear the cylinder of the guide bushing with acid-free grease, and lubricate the screws and spindle before assembling the valve.
Design I: "RA" on the valve housing must face towards 2.

DEUTSCH

Technische Daten

Max. Prüfdruck (Wellrohrelement): 26,5 bar (p_a)
Max. Wasserdruck: Ausf. I = 16 bar (p_a)
Ausf. II = 10 bar (p_a)

Das Ventil ist auf beginnendes Öffnen bei folgenden Verflüssigungsdrücken einzustellen
Ausf. I: Min. 3,5 bar (p_a). Max. 16 bar (p_a)
Ausf. II: Min. 4 bar (p_a). Max. 17 bar (p_a)

Montage

Ausführung I kann in beliebiger Lage angeordnet werden, Ausführung II stets mit dem Wellrohrelement nach oben.
Das Wellrohrelement 10 an das Druckrohr hinter dem Ölausscheider, die Verbindungsleitung an der Oberseite des Druckrohrs anschliessen, um ein Zurückfließen von Schmutz und Öl zu vermeiden.
Vor dem Ventil ein Schmutzfilter anordnen.
Für die Montage von Ausführung I kann eine Konsole (Artikel-Nr. 3N0388) zwischen Oberteil und Ventilhäuse verwendet werden.

Einstellung

Ventil so einstellen, dass der gewünschte Kondensationsdruck bei normalem Betrieb erreicht wird.
Ausf. I: Ein Drehen von 1, so dass der Anzeiger gegen »1« geht, ergibt einen niedrigeren Druck, und umgekehrt.
Ausf. II: Ein Drehen von 27 im Uhrzeigersinn (rechts herum) ergibt einen niedrigeren Druck, und umgekehrt.

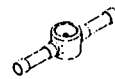

014R9572

014R9572

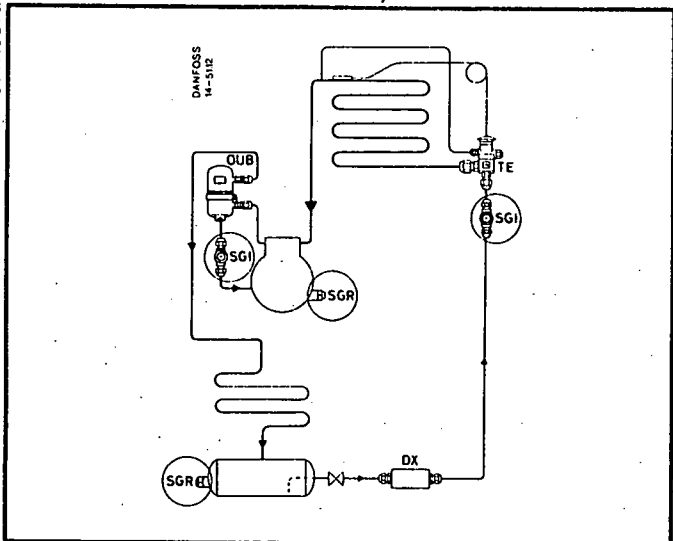

green ~ DRY

yellow ~ WET

R12, R22, R500, R502
 SGI 6, 10, 12, 15 max. 35 bar p_e (500 psig)
 SGI 18, 22 max. 28 bar p_e (400 psig)

DAN3Q-1

KE92-A372 → RI.10.D1.00 9-1982

DANFOSS 14-28.13

SGI

Siloss 15 (15% AG)

MAX. 660°C (1220°F)

DANFOSS 14-48.12

SGI 6 = W14
 SGI 10 = W19
 SGI 12 = W22

DANFOSS 14-58.10

SGI 6 = W16
 SGI 10 = W22
 SGI 12 = W24

DANFOSS 14-47.12

DANFOSS 14-30.12

DAN3Q-2

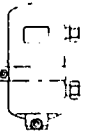

40R9573

40R9573

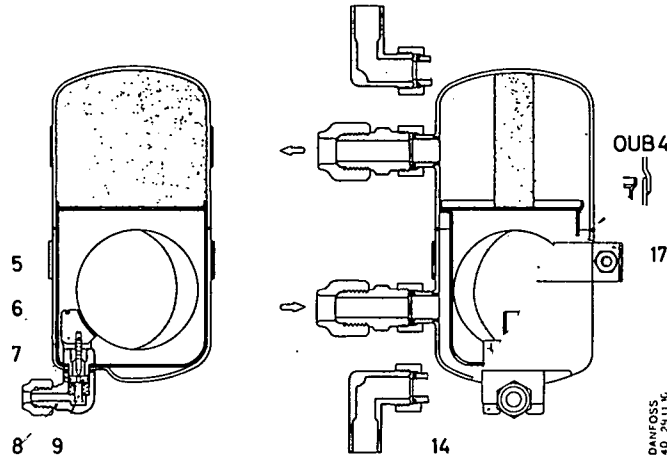

Pos. og reservedele/Position Nos. and Spare Parts/Pos. und Ersatzteile/Pos et pièces de rechange

Pos.		Antal/ No. req./ Anzahl/ Nombre	Best.nr./Code Nos./ Artikel-Nr./N° de code	
			OUB 1	OUB 4
5.	Pakning for 8/Gasket for 8/Dichtung für 8/Joint pour 8	1	040B1117	040B1117
6.	O-ring/O-ring/O-Ring/Joint torique	1	633B1326	633B1326
7.	Dyse/Nozzle/Düse/Orifice	1	040B2320	040B2320
8.	Returolietilslutning/Return oil connection/Anschluss für Ölrücklauf/Raccord de retour d'huile	1	040B1120	040B1120
9.	Dyseholder/Nozzle holder/Düsenhalter/Porte-orifice	1	040B0060	040B0060
14.	Fastgørelsesskrue for 8/Fixing screw for 8/Befestigungsschraube für 8/ Vis de fixation pour 8	2	681X1097	681X1097
17.	Fastgørelsesbøjle/Fastening strap/Befestigungsbügel/Collier de fixation	1	040B0050	040B0055

DANSK

Olieudskiller

TEKNISKE DATA

Max. arbejdsstryk: 22 ato
Max. prøvningstryk: 33 ato
Kølemidler: R 12, R 22, R 502

MONTERING

Olieudskilleren monteres i køleanlæggets trykledning mellem kompressor og kondensator. Alle typer skal anbringes lodret med returolietilslutningen (8) nedad. Udskilleren tilsluttes trykledningen med gennemstrømning som vist med pilene. OUB fastgøres v. hj. a. bøjlen (17). Returoliedningen fra tilslutningen (8) forbindes med kompressorens krømtaphus. Har anlægget tidligere arbejdet uden olieudskiller, tilrådes det i den første tid at holde krømtaphusets oliestand under observation og regelmæssigt aftappe overskydende olie, idet udskilleren vil trække den olie tilbage, som før var fordelt over hele anlægget. Kontrol af olieudskillerens funktion kan foretages v. hj. a. et skueglas type SGI i returoliedningen. Ved korrekt funktion vil en konstant oliestrøm herved kunne iagttages. Monteres OUB på nye anlæg, vil det normalt ikke være nødvendigt at påfylde ekstra olie, da oliebeholderen kun kan rumme små mængder.

SERVICE

Fjernes tilslutningen (8) for returolie, bliver ventilens dyse (7) tilgængelig for rensning.

ENGLISH

Oil separator

TECHNICAL DATA

Maximum operating pressure: 22 atm.g. (315 psig)
Maximum test pressure: 33 atm.g. (470 psig)
Refrigerants: R 12, R 22, R 502.

FITTING

The oil separator is inserted in the delivery line of the refrigerating plant between the compressor and the condenser. All types should be mounted vertically with the return oil connection (8) facing downwards. The separator should be connected to the delivery line with the flow in the direction indicated by the arrows. OUB is fixed by the fastening strap (17). The return oil line from the connection (8) is connected to the compressor crankcase. If the plant concerned has previously been operating without an oil separator, it is recommended that the oil level in the crankcase should be observed at the start and excess oil drained at regular intervals, since the separator will collect the oil which was previously distributed all over the plant. A watch can be kept on the functioning of the oil separator by a sight glass Type SGI in the return oil line. During correct operation the sight glass will show a steady oil flow. If OUB is installed in a new plant, it will normally not be necessary to top up with additional oil, since the oil container can hold only a very small volume.

SERVICING

When the return oil connection (8) is removed, access is given to the valve nozzle (7) for cleaning.

DEUTSCH

Ölabscheider

TECHNISCHE DATEN

Max. Betriebsdruck: 22 atü
Max. Prüfdruck: 33 atü
Kältemittel: R 12, R 22, R 502

MONTAGE

Der Ölabscheider wird in die Druckleitung der Kälteanlage zwischen Kompressor und Verflüssiger montiert. Alle Typen sind senkrecht und mit dem Rückölanchluss (8) nach unten anzubringen. Der Ölabscheider ist mit Durchfluss in der Pfeilrichtung an die Druckleitung anzuschließen. OUB ist mit Hilfe des Bügels (17) zu befestigen. Die Rückölleitung vom Anschluss (8) ist mit dem Kurbelgehäuse des Kompressors zu verbinden. Hat die betreffende Anlage früher ohne Ölabscheider gearbeitet, wird empfohlen, die erste Zeit den Ölstand im Kurbelgehäuse laufend zu beobachten und überschüssiges Öl regelmässig abzulassen, da der Ölabscheider das Öl zurückziehen wird, das früher über die ganze Anlage verteilt war. Eine Überwachung der Funktion des Ölabscheiders ist mit einem Schauglas Typ SGI in der Ölrücklaufleitung möglich. Bei korrekter Funktion kann dadurch ein konstanter Ölstrom beobachtet werden. Bei der Montage des OUB an neuen Anlagen ist es normalerweise nicht erforderlich, zusätzliches Öl nachzufüllen, da der Ölbehälter nur kleine Mengen fassen kann.

WARTUNG

Nach Abbau des Ölrücklaufanschlusses (8) wird die Düse (7) des Ventils für Reinigung zugänglich.

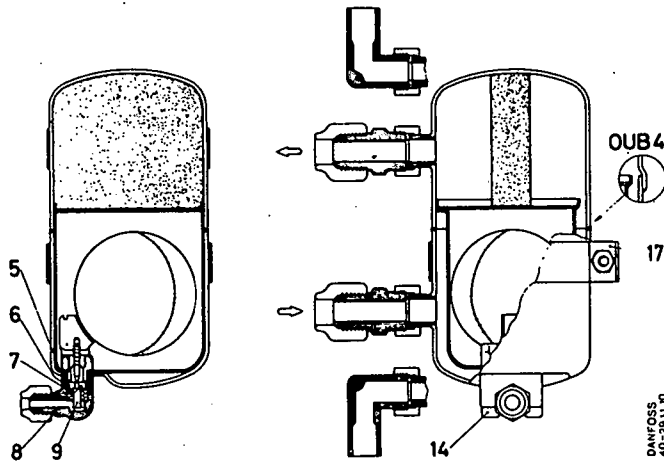

Pos. og reservedele/Position Nos. and Spare Parts/Pos. und Ersatzteile/Pos et pièces de rechange

Pos.		Antal/ No. req./ Anzahl/ Nombre	Best.nr./Code Nos./ Artikel-Nr./N° de code	
			OUB 1	OUB 4
5.	Pakning for 8/Gasket for 8/Dichtung für 8/Joint pour 8	1	040B1117	040B1117
6.	O-ring/O-ring/O-Ring/Joint torique	1	633B1326	633B1326
7.	Dyse/Nozzle/Düse/Orifice	1	040B2320	040B2320
8.	Returrollettilslutning/Return oil connection/Anschluss für Ölrücklauf/Raccord de retour d'huile	1	040B1120	040B1120
9.	Dyseholder/Nozzle holder/Düsenhalter/Porte-orifice	1	040B0060	040B0060
14.	Fastgørelsesskrue for 8/Fixing screw for 8/Befestigungsschraube für 8/ Vis de fixation pour 8	2	681X1097	681X1097
17.	Fastgørelsesbøjle/Fastening strap/Befestigungsbügel/Collier de fixation	1	040B0050	040B0055

FRANCAIS

Séparateur d'huile

CARACTÉRISTIQUES TECHNIQUES

Pression de travail max. 22 atm. eff.
Pression d'essai max. 33 atm. eff.
Fluides frigorigènes: R 12, R 22, R 502

MONTAGE

Monter le séparateur d'huile sur la conduite de refoulement de l'installation frigorifique, entre le compresseur et le condenseur. Tous les types doivent être montés verticalement, le raccord de retour d'huile (8) étant orienté vers le bas.

Relier le séparateur à la conduite de refoulement, avec passage du fluide dans le sens des flèches.

Fixer OUB au moyen du collier (17).

La conduite de retour d'huile venant du raccord (8) doit être reliée au carter du compresseur.

Si l'installation considérée a fonctionné antérieurement sans séparateur d'huile, il est conseillé d'observer pendant un certain temps le niveau d'huile du carter et de vidanger régulièrement l'huile excédentaire car le séparateur ramène au carter l'huile qui était jusqu'ici répartie dans toute l'installation.

Le contrôle du fonctionnement des séparateurs d'huile peut être réalisé en montant un voyant

du type SGI sur la conduite de retour d'huile. Pour un fonctionnement correct, on observera alors un débit d'huile constant.

Si le OUB est monté sur des installations nouvelles, il n'est normalement pas nécessaire de faire une recharge d'huile étant donné que le réservoir ne peut contenir que de faibles quantités d'huile.

ENTRETIEN

En enlevant le raccord de retour d'huile (8), l'orifice (7) de la vanne est accessible pour nettoyage.

Danfoss

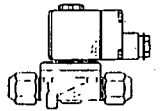

32R9559

32R9559

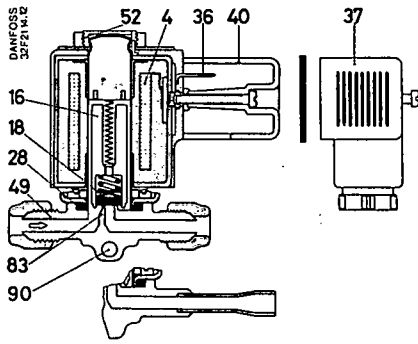

Fig. 1. EVR 2

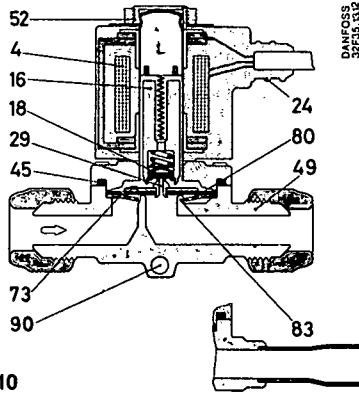

Fig. 2. EVR 10

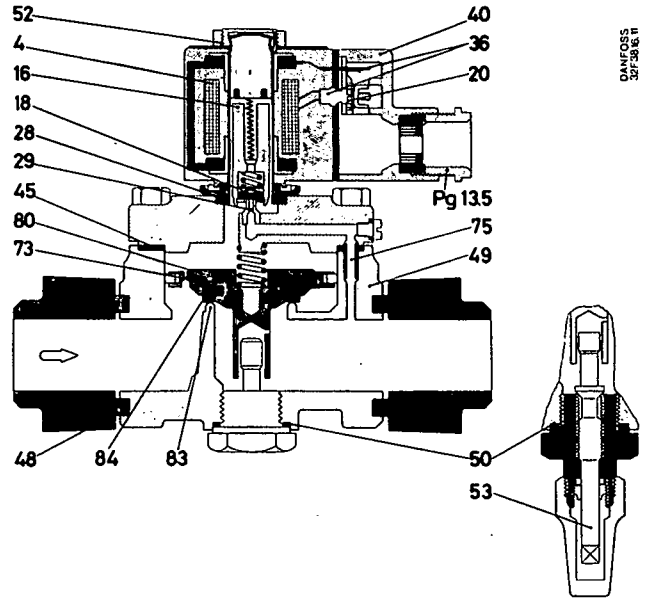

Fig. 3. EVR 25

Fig. 4. EVR 2

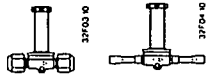

Fig. 5. EVR 2

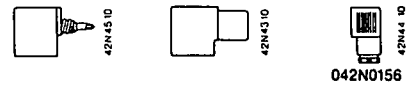

Fig. 6. EVR 3-10



Fig. 9. EVR 3-25

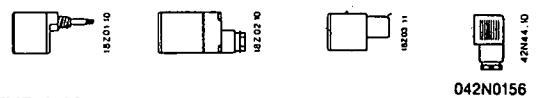

Fig. 7. EVR 15-20

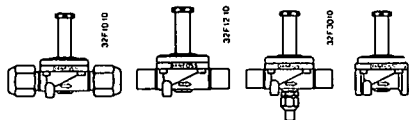

Fig. 8. EVR 25

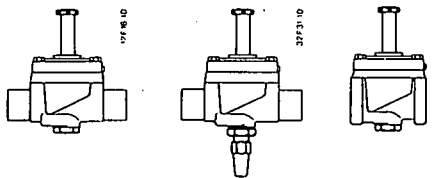

Fig. 10. EVR 2-10

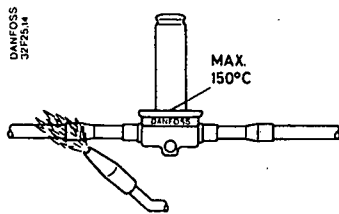

Fig. 11. EVR 15-25

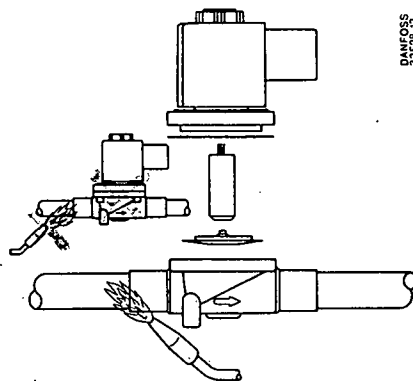
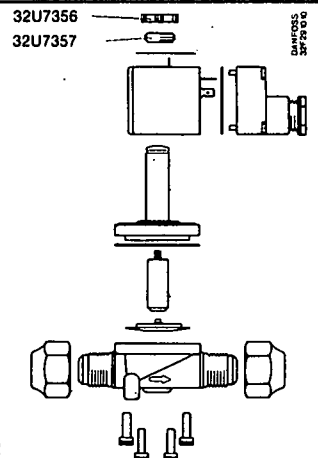

Fig. 12



Magnetventil**Techniske data**

Ventilen er lukket, når spolen er strømløs.
 Kølemidler: R 12, R 22 og R 502 i væske-, damp- eller gasform.
 Ventilen kan også bruges til andre fluoreerede kølemidler, undtagen R 21, når der tages hensyn til både min. og max. medietemperatur.
 Min. medietemperatur: -40°C
 Max. medietemperatur: $+105^{\circ}\text{C}$
 Max. driftstryk (p_a): 35 bar = 3500 kPa
 Max. prøvningstryk (p_a): 46 bar = 4600 kPa
 Max. tilladelig spændingsvariation
 EVR 2: $\pm 10\%$ (a.c., d.c.)
 EVR 3-25: $\pm 10\%$ (a.c.), $\pm 10\%$ (d.c.)

Max. åbningsdifferenstryk (MOPD), spole-spænding, -frekvens og -effekt: Se spole- og topskilt.

Identifikation

De sidste fire cifre af bestillingsnummeret for underparten er stemplet i ventilhuset.
 EVR 20 til d.c. har profileret anker.

Konstruktion

4. Spole
16. Anker
16. Pilotventilplade
- Jordskrue
24. Tilslutning for stålslange
28. Pakning
29. Pilotdyse
36. AMP stikben
37. AMP stikdåse (i henhold til DIN 43650)
40. Dækhætte/Klemdåse
45. Pakning for ventildæksel
48. Flangepakning
49. Ventilhus
50. Pakning
52. Låseknop og topmøtrik
53. Spindel for manuel åbning
73. Udligningshul
75. Pilotkanal
80. Membran/Servostempel
83. Ventilseade
84. Hovedventilplade
90. Monteringshul

Montering

Ventilen kan monteres i vilkårlig stilling; dog bør spolen ikke vende nedad af hensyn til eventuel snavssamling i ankerrøret.

Pilen på ventilhuset viser gennemstrømningsretningen.
 Ventilen kan spændes fast ved hjælp af en skrue gennem monteringshullet 90. EVR 2-10 kan desuden monteres på en konsol. Konsollen kan leveres på bestillingsnummer 032F0086.

EVR 2, 3, 6 og 10 med loddetilslutning (fig. 10):

Når disse ventiler loddes i rørledningen uden adskillelse af ventilhuset, må arbejdstemperaturen ikke blive højere end 700°C . Anvend derfor et sølvlod med lavt smeltepunkt. Hold loddeflammen væk fra ankerrøret da pakningen ikke tåler temperaturer over 150°C .

EVR 15, 20 og 25 med loddetilslutning (fig. 11):

Disse ventiler skal altid skilles ad inden ilodning.

El-tilslutning

Før spolen tilsluttes, kontrollér da, om spolens angivne spænding og frekvens er den samme som nettets.

Spoler med kabel er forsynet med en grøn gul ledning, som skal forbindes til jord.

Ved spoler med AMP tilslutning skal spade- eller klemmestikket forbindes til jord.

Spoler med klemdåse er forsynet med en Pg 13,5 kabelforskrining for 6-14 mm kabel. Klemdåsens indvendige jordskrue 20 skal forbindes til jord.

Service

Servostemplet 80 i EVR 25 udtages lettest med en af dækselskrueene, der skrues ind i gevindet midt i servostemplet.

Før membranen/servostemplet 80 monteres efter eventuel rensning af ventilen, skal det kontrolleres, at udligningshullerne er helt fri for snavs.

Støtteskiven under membranen skal anbringes med den bukkede kant nedad.

Hvis EVR skilles ad efter længere tids drift, bør pakningen 28 altid udskiftes. Bestillingsnr., se skemaet.

Når en spole skal bestilles, bedes følgende angivet: Ventiltype, spænding, frekvens og tilslutningsart (enten 1 m kabel, AMP tilslutning eller klemdåse).

AMP stikdåse 37, IP 65, leveres på bestillingsnr. 042N0156.

Enhed for manuel åbning af EVR 25 kan leveres på bestillingsnr. 032K1218.

Ventiltype	Anker 16+ pakning 28/45	Membran/Servostempel 80 + pakning 45
EVR 2	032F0087	
EVR 3	032F0088	
EVR 6	032F0089	032F0090
EVR 10	032F0091	032F0092
EVR 15	032F0093	032F0094
EVR 20	032F0095	032F0096
EVR 25	032F0088	032F0098

ENGLISH

Solenoid valve**Technical data**

The valve is closed when the coil is deenergized.

Refrigerants: R 12, R 22 and R 502 in liquid, vapour or gas form.

The valve can also be used for other fluorinated refrigerants, except R 21, providing the operating conditions are within the min./max. temperature conditions quoted for the valve.

Min. temperature of medium: -40°C (-40°F)
 Max. temperature of medium: $+105^{\circ}\text{C}$ ($+221^{\circ}\text{F}$)

Max. operating pressure (p_a): 35 bar =

3500 kPa = 498 psig

Max. test pressure (p_a): 46 bar = 4600 kPa = 654 psig

Max. permissible voltage variation:

EVR 2: $\pm 10\%$ (a.c., d.c.)

EVR 3-25: $\pm 10\%$ (a.c.), $\pm 10\%$ (d.c.)

Max. opening differential pressure (MOPD), coil voltage, frequency and power: See coil and top label.

Identification

The last four ciphers of the code No. for the valve body are stamped on the body.
 The EVR 20 for d.c. has a ribbed armature.

Design

4. Coil
16. Armature
18. Pilot valve plate
20. Earth screw
24. Connection for steel hose
28. Gasket
29. Pilot orifice
36. AMP connector
37. AMP socket (to DIN 43650)
40. Protective cap/Terminal box
45. Valve cover gasket
48. Flange gasket
49. Valve body
50. Gasket
52. Lock button and top nut
53. Manual opening spindle
73. Equalizing hole
75. Pilot channel
80. Diaphragm/Servo piston

83. Valve seat
84. Main valve plate
90. Fixing hole

Fitting

The valve can be mounted in any position, except with the coil pointing downwards. This is to prevent any foreign matter collecting in the armature tube.

The arrow on the valve body indicates the direction of flow.

The valve can be securely mounted in position with a screw through the fixing hole, 90. The EVR 2-10 can also be mounted on a bracket which can be ordered under code No. 032F0086.

EVR 2, 3, 6 and 10 with solder connection (fig. 10):

When the valves are soldered into pipelines without dismantling the valve body, the working temperature must not be higher than 700°C . Therefore, use a silver solder with a low melting point. Hold the soldering flame away from the armature tube since the gasket will not stand temperatures over 150°C .

EVR 15, 20 and 25 with solder connection (fig. 11):

These valves must always be dismantled before soldering.

Electrical connection

Before connection the coil, check that the stated coil voltage and frequency correspond to the mains values.

The green-yellow wire of coils with a cable must be connected to earth.

With AMP-connected coils, the spade connector marked \perp must be connected to earth.

Coils with a terminal box are fitted with a Pg 13.5 screwed cable entry for 6-14 mm cable. Connect the internal earth screw 20 in the box to earth.

Service

The servo piston, 80, in the EVR 25 is easiest removed with one of the cover screws which should be screwed into the thread in the centre of the servo piston.

Before the diaphragm/servo piston, 80, is fitted, after cleaning the valve for example, make sure that the equalizing hole is completely free of dirt.

The backing washer under the diaphragm must be fitted with its bent edge downwards. If the EVR valve is dismantled after being in operation for some time, the gasket 28 ought always to be replaced. Code No., see table.

When ordering a coil, please state: valve type, voltage, frequency and type of connection (either 1 m cable, AMP connector or terminal box).

The AMP socket, 37, IP 65, can be obtained under code No. 042N0156.

The unit for manual opening of the EVR 25 can be obtained under code No. 032K1218.

Valve type	Armature 16+ gasket 28/45	Diaphragm/Servo-piston 80 + gasket 45
EVR 2	032F0087	
EVR 3	032F0088	
EVR 6	032F0089	032F0090
EVR 10	032F0091	032F0092
EVR 15	032F0093	032F0094
EVR 20	032F0095	032F0096
EVR 25	032F0088	032F0098

DEUTSCH

Magnetventil**Technische Daten**

Das Ventil ist bei stromloser Spule geschlossen. Kältemittel: R 12, R 22 und R 502, flüchtig, dampf- oder gasförmig.