

INSTRUCTIONS HANDBOOK

# EPS 60 XP



**APPLICARE**

**TARGA**

**CARATTERISTICHE**

We wish to thank you for the preference granted to us by purchasing one of **COLDELITE** machines.

To the best guarantee, since 1993 **COLDELITE** has submitted its own Quality System to the certification according to the international Standard ISO 9001-94, nowadays its production has got UNI-EN-ISO 9001-2000 Certified Quality System.

Moreover, Carpigiani machines comply with following European Directives:

- "Machinery" Directive 98/37/EC,
- "Low Voltage" Directive 2006/95/EC,
- "EMC" Directive 2004/108/EC,
- "PED" Directive 97/23/EC,
- Regulation 2004/1935/EC relating to "Materials and articles in contact with foodstuffs"

#### **COLDELITE**

Via Emilia, 45 - 40011 Anzola Emilia (Bologna) - Italy

Tel. 051-6505111 - Fax 051-732178

This handbook may not be reprinted, transferred, registered, recorded in a retrieval system, nor translated in other languages unless otherwise previously agreed with **COLDELITE**.

The purchaser has the right to reprint it for his own office use.

**COLDELITE** policy pursues a steady research and development, thus it reserves the right to make changes and revisions whenever deemed necessary and without being bound to previous statements to the purchaser.

<b>Edizione: 2</b>	<b>Data: 09/10</b>	<b>Modifiche: Sez. 1.2.2, Sez. 3.4.1, Sez. 4.1, Sez. 5.3, Sez. 5.7</b>
<b>Redatto: AM</b>	<b>Verificato: RL</b>	<b>Approvato: RV</b>

**INDEX**

**SECT. FOREWORD ..... 5**  
 INSTRUCTION HANDBOOK ..... 5  
 PURPOSE ..... 5  
 HANDBOOK STRUCTURE ..... 5  
 ADDITIONAL DOCUMENTATION ..... 5  
 CONVENTIONAL SYMBOLS ..... 6  
 SAFETY ..... 7  
 QUALIFICATION OF THE STAFF ..... 7  
 WARNING ..... 7

**SECT. 1 GENERAL INFORMATION**

**1.1 GENERAL INFORMATION ..... 9**  
 1.1.1 MANUFACTURER'S IDENTIFICATION DATA ..... 9  
 1.1.2 INFORMATION ABOUT SERVICE ..... 9  
 1.1.3 INFORMATION TO THE USER ..... 9  
**1.2 INFORMATION ABOUT THE MACHINE ..... 9**  
 1.2.1 GENERAL DATA ..... 9  
 1.2.2 TECHNICAL FEATURES ..... 10  
 1.2.3 MACHINE GROUPS LOCATION ..... 11  
**1.3 INTENDED USE ..... 11**  
**1.4 NOISE ..... 11**  
**1.5 STORING A MACHINE ..... 11**  
**1.6 DISPOSAL OF PACKING STUFFS ..... 11**  
**1.7 WEEE (Waste Electrical and Electronic Equipment) ..... 12**

**SEC. 2 INSTALLATION**

**2.1 ROOM NECESSARY TO THE MACHINE USE ..... 13**  
**2.2 WATER SUPPLY CONNECTION ..... 13**  
**2.3 MACHINES WITH AIRCOOLED CONDENSER ..... 13**  
**2.4 MACHINES WITH WATERCOOLED CONDENSER ..... 14**  
 2.4.1 WATER VALVE ADJUSTMENT ..... 14  
**2.5 ELECTRICAL CONNECTION ..... 14**  
 2.5.1 REPLACING A POWER CABLE ..... 14  
**2.6 LOCATION ..... 15**  
**2.7 REFILLING ..... 15**  
**2.8 MACHINE TESTING ..... 15**

**SEC. 3 INSTRUCTIONS FOR USE**

**3.1 MACHINE SAFETY WARNINGS ..... 17**  
**3.2 MACHINE CONFIGURATION ..... 17**  
**3.3 CONTROLS ..... 18**  
 3.3.1 PUSH-BUTTON PANEL ..... 18  
 3.3.2 FUNCTIONS ..... 18  
**3.4 MACHINE STARTING ..... 20**  
 3.4.1 USE OF THE DISPENSING SPIGOT ..... 20

**SEC. 4 SAFETY DEVICES**

**4.1 ALARMS ON DISPLAY ..... 21**  
**4.2 BLACKOUT ..... 22**

**SEC. 5 CLEAN OUT, DISASSEMBLING AND REASSEMBLING OF PARTS IN CONTACT WITH THE PRODUCT**

5.1 EXTERIOR CLEAN OUT ..... 23  
 5.2 PRELIMINARY CLEAN OUT ..... 23  
 5.3 DISASSEMBLING THE SPIGOT PISTON ..... 23  
 5.4 DISASSEMBLING THE TANK COVER ..... 24  
 5.5 DISASSEMBLING THE BEATER ..... 24  
 5.6 HYGIENE ..... 25  
 5.7 SANITIZATION ..... 25

**SEC. 6 MAINTENANCE**

6.1 SERVICE TYPOLOGY ..... 27  
 6.2 WATERCOOLING ..... 27  
 6.3 AIRCOOLING ..... 27  
 6.4 ORDERING SPARE PARTS ..... 27  
 6.5 TABLE OF EQUIPMENT ..... 28

**SEC. 7 TROUBLESHOOT GUIDE**

7.1 TROUBLESHOOT GUIDE ..... 29

## FOREWORD

## INSTRUCTION HANDBOOK

Editing this handbook, it was taken into due account European Community directions on safety standards as well as on free circulation of industrial products within E.C.

## PURPOSE

This handbook was conceived taking machine users' needs into due account. Topics relevant to a correct use of the machine have been analyzed in order to keep unchanged in the long run quality features characterizing **COLDELITE** machines all over the world. A significant part of this handbook refers to the conditions necessary to the machine use and to the necessary procedure during cleanout as well as routine and special maintenance. Nevertheless, this handbook cannot meet all demands in details. In case of doubts or missing information, please apply to:

---

**COLDELITE**

Via Emilia, 45 - 40011 Anzola Emilia (Bologna) - Italy  
Tel. 051-6505111 - Fax 051-732178

---

## HANDBOOK STRUCTURE

This handbook is divided in sections, chapters and subchapters in order to be consulted more easily.

### SECTION

A section is the part of the handbook identifying a specific topic related to a machine part.

### CHAPTER

A chapter is that part of a section describing an assembly or concept relevant to a machine part.

### SUBCHAPTER

It is that part of a chapter detailing the specific component of a machine part.

It is necessary that each person involved in the machine operation reads and clearly understands those parts of the handbook of his/her own concern, and particularly:

- The Operator must read the chapters concerning the machine star-up and the operation of machine components.
- A skilled technician involved in the installation, maintenance, repair, etc., of the machine must read all parts of this handbook.

## ADDITIONAL DOCUMENTATION

Along with an instruction manual, each machine is supplied also with additional documentation:

- **Part list:** A list of spare parts which is delivered together with the machine for its maintenance.
- **Wiring diagram:** A diagram of wiring connections is placed in the machine.

### ATTENTION

**Before using the machine read carefully the instruction handbook.  
Pay attention to the safety instructions.**



## CONVENTIONAL SYMBOLS



### CAUTION: ELECTRIC SHOCK DANGER

The staff involved is warned that the non-observance of safety rules in carrying out the operation described may cause an electric shock.



### CAUTION: GENERAL HAZARD

The staff involved is warned that the operation described may cause injury if not performed following safety rules.



### NOTE

*It points out significant information for the staff involved.*



### WARNINGS

The staff involved is warned that the non-observance of warning may cause loss of data and damage to the machine.



### PROTECTIONS

This symbol on the side means that the operator must use personal protection against an implicit risk of accident.

### QUALIFICATION OF THE STAFF



### MACHINE OPERATOR

He/she is an unskilled person, who has no specific expertise and can only carry out easy chores, such as the machine operation by means of controls available on the push-button panel, and filling and drawing of products used during operations.



### MAINTENANCE ENGINEER

He/she is a skilled engineer for the operation of the machine under normal conditions; he/she is able to carry out interventions on mechanical parts and all adjustments, as well as maintenance and repairs. He/she is qualified for interventions on electrical and refrigeration components.



### COLDELITE ENGINEER

He/she is a skilled engineer the manufacturer assigned to field interventions for complex jobs under particular conditions or in accordance with agreements made with the machine's owner.

## SAFETY

When using industrial equipment and plants, one must be aware of the fact that drive mechanisms (rotary motion), high voltage components, as well as parts subject to high temperatures may cause serious damage to persons and things.

Who is in charge of plant safety must be on the look-out that

- An incorrect use or handling shall be avoided
- Safety devices must neither be removed nor tampered with
- The machine shall be regularly serviced
- Only original spare parts are to be used especially as far as those components with safety functions are concerned (ex.: protection microswitches, thermostats).

To achieve the above, the following is necessary:

- At the working place an instruction manual relevant to the machine should be available.
- Such documentation must be carefully read and requirements must consequently be met.
- Only adequately skilled personnel should be assigned to electrical equipment.
- Be on the look out that no technician will ever carry out interventions outside his own knowledge and responsibility sphere.

## QUALIFICATION OF THE STAFF

Staff attached to the machine can be distinguished according to training and responsibility as follows:

### OPERATOR

- A person who has not necessarily a high technical knowledge, just trained for ordinary operation of the machine, such as: startup, stop, filling, basic maintenance (cleanout, simple blocking, instrumentation checkings, etc.).

### SKILLEDENGINEER

- A person engaged on more complicated operations of installation, maintenance, repairs, etc.

### IMPORTANT!

One must be on the look-out that the staff does not carry out any operation outside its own sphere of knowledge and responsibility.

### NOTE:

*According to the standard at present in force, a SKILLED ENGINEER is who, thanks to*

- *training, experience and education,*
  - *knowledge of rules, prescriptions and interventions on accident prevention,*
  - *knowledge of machine operating conditions,*
- is able to realize and avoid any danger and has also been allowed by the person in charge of plant safety to carry out all kinds of interventions.*

## WARNING

When installing the machine, insert a differential magnetothermal protection switch on all poles of the line, adequately sized to the absorption power shown on machine data plate and with contact opening of 3 mm at least.

- Never put your hand into the machine, alike during production and cleaning operations. Before carrying out any maintenance operation, make sure that the machine is in “STOP” position and main switch has been cut out.
- It is forbidden to wash the machine by means of a bolt of water under pressure.
- It is forbidden to remove panels in order to reach the machine inside before having disconnected the machine.
- **COLDELITE** is not responsible for any accident that might happen during operation, cleaning and/or servicing of its units, if this warning has not been fully complied with.





# 1 GENERAL INFORMATION

## 1.1 GENERAL INFORMATION

### 1.1.1 Manufacturer's identification data

The machine has a data plate carrying manufacturer data, machine type and serial number, assigned when it is manufactured.

Copy of machine data plate to be found on first page of this handbook.

<b>COLDELITE</b>		ANZOLA EMILIA - BOLOGNA - ITALY	
Matr. ●		Cod. ●	
V ●	A ●	Hz ●	kW ●
Gas	kg		
CE			

*Legend:*

A= Serial number  
 B= Machine type  
 C= Voltage  
 D= Main-switch amperometric value  
 E= Gas type and weight  
 F= Machine code  
 G= Condensation  
 H= Frequency  
 I= Power input

### 1.1.2 Information about service

All operations of routine maintenance are here described in section "Maintenance"; any additional operation requiring technical intervention on the machine must be cleared with the manufacturer, who will also examine the possibility of a factory technician field intervention.

### 1.1.3 Information to the user

- The manufacturer of the machine is at user's disposal for any explanation and information about the machine operation.
- In case of need, please call the local distributor, or the manufacturer if no distributor is available.
- Manufacturer's service department is available for any information about operation, and requests of spare parts and service.



## 1.2 INFORMATION ABOUT THE MACHINE

### 1.2.1 General data

EPS XP are pasteurizers which prepare, pasteurize, homogenize and age ice cream mixes to other units.

An electronic microprocessor steadily checks each working cycle selected.

Two alphanumerical monitors display all steps of a working cycle and send audio-visible messages.

The following are the main components:

- two-speed beater;
- display console with low voltage 24 V controls;
- electrical, freezing and soundproofing units complying with international standards;
- graduated tank, with inside water dispenser for wash;
- high resistant steel frame, treated with rust inhibitors; varnished aluminium panels.

**COLDELITE** recommends to always use high quality ingredients for the preparation of confectionery products, in order to satisfy your customers, even the most hard-to-please ones.

Any saving made to the prejudice of quality will surely turn into a loss much bigger than the saving itself.

Bearing in mind the above statements, please take heed of the following suggestions:

- Choose high quality natural ingredients.
- Follow closely instructions given by your supplier.
- Do not alter your supplier's recipes, by adding, for instance, water or sugar.
- Taste your products before serving and start selling only if entirely satisfactory.
- Make sure your staff always keeps the machine clean.
- Have your machine serviced always by companies authorized by COLDELITE.

**1.2.2 Technical features**

MODEL	Tank capacity		Electric power			Installed power	Condenser	Dimensions cm			Net weight
	Min litres	Max litres	Volts	Hz	Ph			kW	at the base		Height mm
						Width mm			Depth mm		
EPS 60 XP	30	60	400	50	3	6,5	Water	39	85	103	162



**NOTE:**

*Dimensions herebelow reported may change depending on type of condensation.*

Performances featured by a 25°C room temperature and 20°C cooling water temperature.

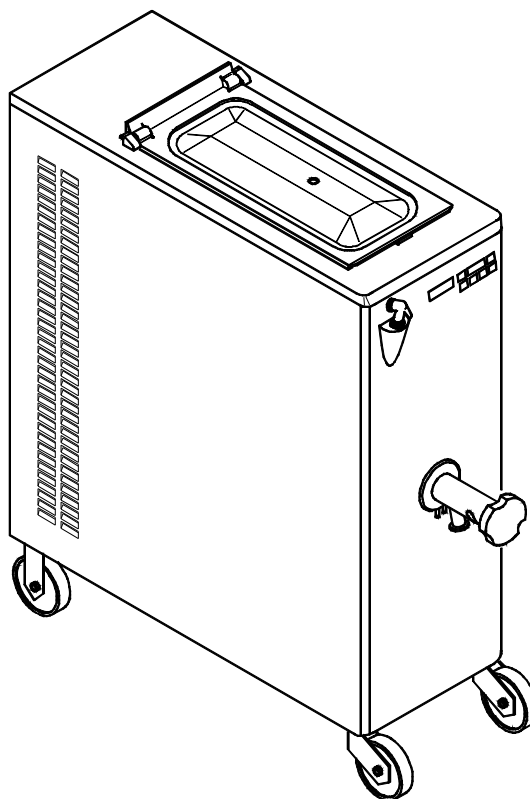

### 1.2.3 Machine groups location

Caption

- 1 Tank with cover
- 2 Control panel
- 3 Dispensing spigot
- 4 Spout

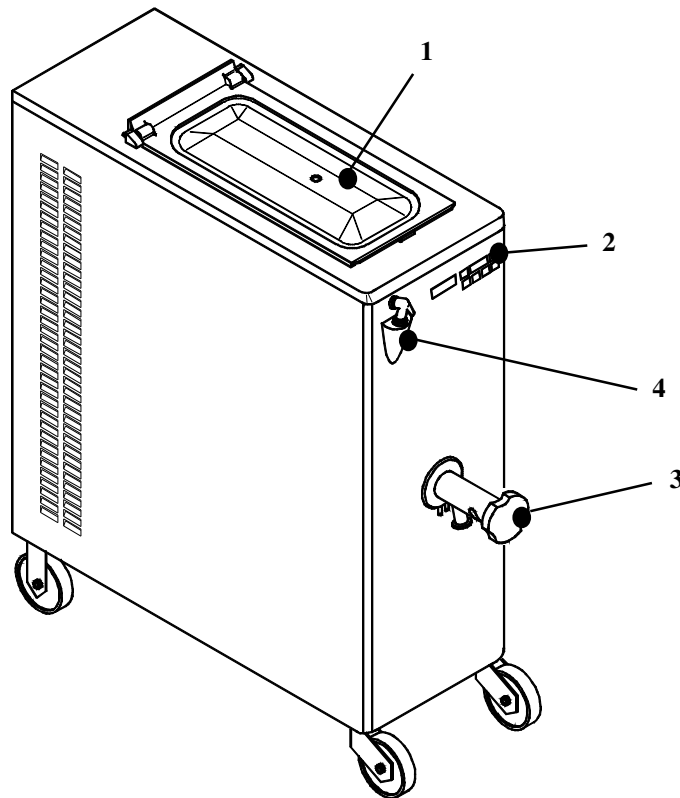

### 1.3 INTENDED USE

EPS XP must only be used conforming with contents of paragraph 1.2.1 "General Information", within the functional limits hereunder reported:

Voltage:	±10%
Air min. temperature	10°C
Air max. temperature	43°C
Water min. temperature	10°C
Water max. temperature	30°C
Water min. pressure	0.1 MPa (1 bar)
Water max. pressure	0.8 MPa (8 bar)
Max air relative humidity:	85%

- This machine has been designed for its use in rooms not subject to explosion-proof laws; its use is thus bound to complying rooms and normal atmosphere.

### 1.4 NOISE

The steady acoustic pressure level weighed A in a working place alike by watercooled and by aircooled machines is less than 70 dB(A).

### 1.5 STORING A MACHINE

The machine must be stored in a dry and dump-free place.  
Before storing the machine, wrap it in a cloth in order to protect it against dust and else.

### 1.6 DISPOSAL OF PACKING STUFFS

When opening the packing crate, divide packing stuffs per type and get rid of them according to laws in force in machine installation country.

## 1.7 WEEE (Waste Electrical and Electronic Equipment)

In accordance with European Directive 2002/96/EC on WEEE (Waste Electrical and Electronic Equipment), the presence of the above symbol on the product or on its packaging indicates that this item must not be disposed of in the normal unsorted municipal waste stream. Instead, it is the user's responsibility to dispose of this product by returning it to a collection point designated for the recycling of electrical and electronic equipment waste. Separate collection of this waste helps to optimize the recovery and recycling of any reclaimable materials and also reduces the impact on human health and the environment.

For more information concerning the correct disposal of this product, please contact your local authority or the retailer where this product was purchased.



## 2. INSTALLATION

### 2.1 ROOM NECESSARY TO THE MACHINE USE

The machine must be installed in such a way that air can freely circulate all around. Rooms for the approach to the machine must be left free in order to enable the operator to act without constraint and also to immediately leave working area, if need be. The minimum approach room to working area should be at least 150 cm in consideration of space taken by opened doors.

#### ATTENTION

**Machines with aircooled condenser must be installed no closer than 50 cm to any wall in order to allow free air circulation around the condenser.**

#### NOTE

*An insufficient air circulation affects operation and output capacity of the machine.*

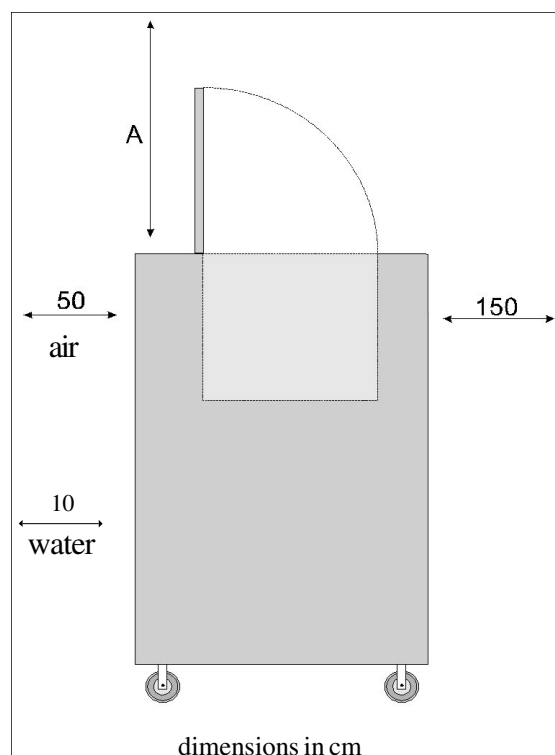

### 2.2 WATER SUPPLY CONNECTION

The machine must be connected to running water which pressure must not be higher than 0,8 MPa (8 bars).

By aircooled machines, water connection for drinking water (for machine wash) is placed under the machine.

By watercooled machines water connections (for machine wash and gas cooling) are placed on upper panel.

### 2.3 MACHINE WITH AIRCOOLED CONDENSER

Machines with aircooled condenser must be installed no closer than 50 cm to any wall in order to allow free air circulation around the condenser.

#### NOTE

*An insufficient air circulation affects operation and output capacity of the machine.*



## 2.4 MACHINES WITH WATERCOOLED CONDENSER



To make the machine run, a watercooled machine must be connected to running water supply, or to a cooling tower.

Water must have a pressure of 0.1 MPa and 0.8 MPa (1-8 bar) at least, and a delivery at least equal to the estimated hourly consumption.

Connect inlet pipe marked by plate "Water Inlet" to water supply installing a shut-off valve, and outlet pipe marked by plate "Water Outlet" to a drain pipe, installing a shut-off valve.

### 2.4.1 Water valve adjustment

#### IMPORTANT

If water valve needs be reset, this operation will have to be carried out by skilled personnel, only.

Valve adjustment must be carried out in such a way that no water flows when machine is off and lukewarm water flows when machine is on.

#### NOTE

*Water consumption increases if temperature of entering water is above 20°C.*

---

#### ATTENTION:

**Do not leave the machine in a room with temperature below 0°C without first draining water from the condenser.**

---

## 2.5 ELECTRIC CONNECTION

Before connecting the machine to the mains, check that machine voltage indicated in data plate corresponds with the mains.

Insert a differential magnetothermal protection switch adequately sized to absorption capacity required and with contact opening of 3 mm at least.

The machines are delivered with a 5 wire cable: blue wire must be connected to the neutral lead.

---

#### IMPORTANT

**Yellow/green ground wire must be connected to an adequate ground plate.**

---

### 2.5.1 Replacing the power cable

Should the machine main cable be damaged, it must be replaced immediately with one having similar features. Replacement shall be carried out by skilled technicians, only.

---

#### IMPORTANT

##### Direction of rotation

***Eps xp* beater direction is clockwise in beating mode and full charge, whilst it is anticlockwise in half charge mode.**

---



### Reversal of rotation direction

If the beater rotation is not correct, reverse it by interchanging two of the three leads coming from the circuit breaker.



## 2.6 LOCATION

The machine is provided with castors for an easy positioning; a mechanical block system, once engaged, prevents machine from moving and keeps it standstill.

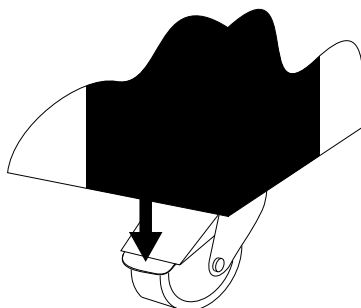

## 2.7 REFILLING

Motor installed in the machine is of the type with lubrication for life; no action of checking/replacing or topping up is necessary.

Gas filling necessary to the freezing system is carried out at **COLDELITE** works during machine postproduction testing.

If a gas addition happens to be made, this must be carried out by skilled technicians, only, who can also find out trouble origin.



## 2.8 MACHINE TESTING

A postproduction test of the machine is carried out at **COLDELITE** premises; operation and output functionality of the machine are thoroughly tested.

Machine test at end user's must be carried out by skilled technicians or by one of **COLDELITE** engineers.

After the machine positioning and correct connections, also carry out all operations necessary to functional check and test of the machine.





### 3. INSTRUCTIONS FOR USE

#### 3.1 MACHINE SAFETY WARNINGS

When using industrial equipment and plants, one must be aware of the fact that drive mechanisms (rotary motion), high voltage components, as well as parts subject to high temperatures may cause serious damages to persons and things.

Who is in charge of plant safety must be on the look-out that

- an uncorrect use or handling is avoided
- Safety devices are neither removed nor tampered
- Only are original spare parts to be used especially as far as those components with safety functions are concerned (ex.: protection microswitches, thermal relays).

To achieve the above, the following is necessary:

- At working place an instruction manual relevant to the machine should be available.
- Such documentation must be carefully read and regulations must consequently be followed.
- Only must adequately skilled personnel be assigned to electrical equipment.



#### 3.2 MACHINE CONFIGURATION

The machine consists of a transmission of movement for beater assembly, a heating and cooling system with aircooled or watercooled condenser.

The product is prepared by pouring a mix into the tank and starting the production cycle, while referring to minimum and maximum quantities reported in Section 1.

When the cycle ends, the product can be taken out from the special spigot.

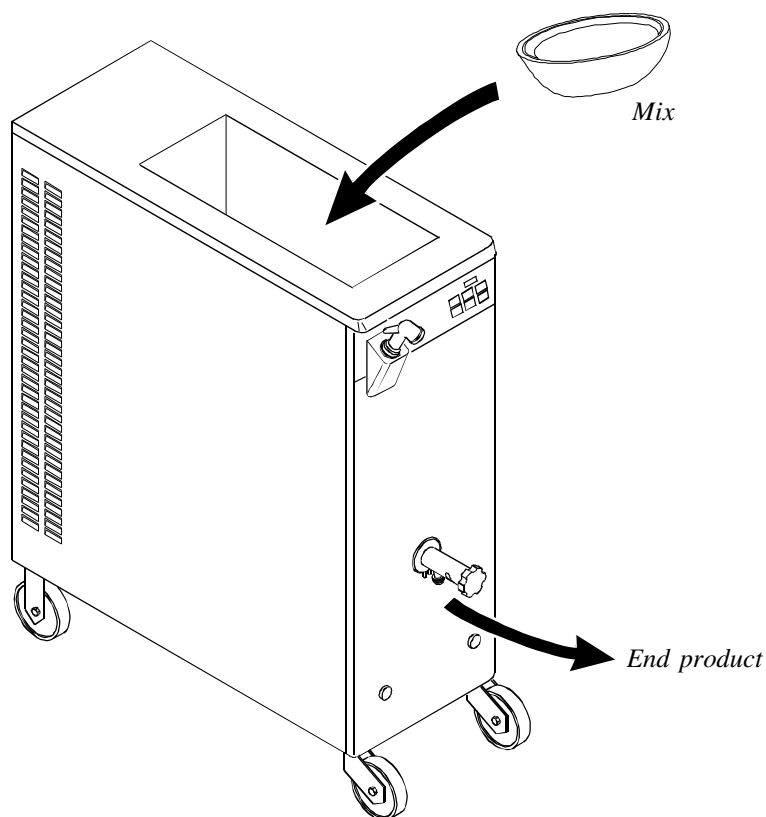

## 3.3 CONTROLS

### 3.3.1 Push-button panel

The machine is provided with a push-button panel on its front side; each push-button has symbols explaining relevant functions.



### 3.3.2 Functions

#### Function insert leds

When one of the leds on top left side of each push button switches on, it means the function corresponding with the symbol next to the same led, has been inserted.



#### DISPLAY

EPS XP is provided with an alphanumeric display usually displaying a series of messages as soon as the machine is switched on and during its operation.



#### STOP

In this function the machine is stopped and relevant red led is on. On the display you will see STOP.



#### Pasteurization

There are 2 modes for pasteurization, namely:

- Full Charge Cycle
- Half charge Cycle

In order to select the Cycle **Full Charge**, press the Pasteurization push-button.

You will get activation of

- Beating (high speed = clockwise)
- Side resistances (TTR)

After pressing the Pasteurization push-button, the set temperature will reach the last value among 65°C, 85°C and 90°C and on display you will read (for ex. 85°C):

Pasto +85°C

within 2" you can choose among 3 available Set values with the arrow-

button  , i.e.,:

+85°C, +90°C, +65°C.

The cycle **Half Charge** is inserted by pressing the Pasteurization push-button (select Set with the Arrow button as by the Cycle Full Charge) and then the

Half Charge push-button  . On display:

1/2 Pasto +85°C Mix +04°C

You will get activation of

- Beating (Low speed = anticlockwise)
- Side resistances (TTR)



### Cooling

In cooling mode

- Compressor
- Solenoid valve (EVF)
- Beater (high speed = clockwise rotation) will be activated

In cooling, too, the beater always runs together with the Compressor. After selecting the Cooling push-button, the display will show

Set +04°C Mix +14°C
---------------------

When the set value is reached, Compressor, solenoid valve and Beater will stop. The Beater will thence start every 30' and runs 15" everytime the Compressor starts to cool the mix till the temperature set is reached.

The mix is thus controlled by thermostat for indefinite time.

In this case, low beating is activated, unless it is modified as described below.

Beating modes can be changed by pressing the Beating push-button and, as by heating, the result will be as follows:

- Beating led fixed: high speed with clockwise rotation
- Beating led blinking: low speed with anticlockwise rotation

In this step the temperature TGV will be controlled for anti-icing.



### Beating

By pressing the Beating push-button, the display will show:

TIMER 30:00 Mix +05°C
--------------------------

Beating (high speed = clockwise) will be activated.

The display will show on top the time of 30 minutes, after which the machine will set at STOP, whereas, down, it will show the mix temperature.

By pressing the beating push-button you can modify Beating mode as follows:

- High speed (clockwise rotation), Beating led fixed
- Low speed (anticlockwise rotation), Beating led blinking



### Shower

By pressing the Shower push-button you allow water inlet through the nozzle located on machine front.

Water inlet stops by pressing again the Shower push-button or STOP.

There is also an automatic water stop after 1 minute inlet.

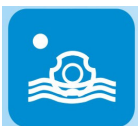

### Water tap

By pressing this push-button you activate mix spigot washing. Water inlet lasts 3 seconds.

When time is over, spigot wash stops automatically and relevant led will switch off.

### 3.4 MACHINE STARTING

After washing, sanitizing and thoroughly rinsing the machine right before its use, as per previous descriptions, pour the mix into the tank according to the quantity desired and respecting the minimum and maximum values shown in the table (Sec. 1.2.2); the tank is provided with an inside graduation for an approximate indication of mix quantity therein contained (see picture below).

Before pouring the mix, make sure that the dispensing spigot is perfectly closed.

*Note: a non perfectly closed tank cover hinders the machine functioning.*

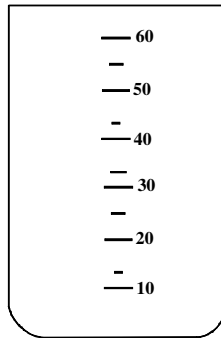



The cycle starts after inserting the **STOP** position (led is on).

There are 2 modes for pasteurization, namely:

- Full Charge Cycle
- Half charge Cycle

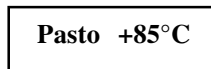
In order to select the Cycle **Full Charge**, press the Pasteurization push-button. the set temperature will now reach the last value among 65°, 85° and 90° and on display you will read (for ex. 85°):



within 2" you can choose among 3 available Set values with the arrow-button  , i.e., +85°C, +90°C, +65°C.

The cycle **Half Charge** is inserted by pressing the Pasteurization push-button (select Set with the Arrow button as by the Cycle Full Charge) and then the Half Charge push-button



. On display:



#### 3.4.1 Use of the dispensing spigot

To take the mix out, turn the knob anticlockwise.

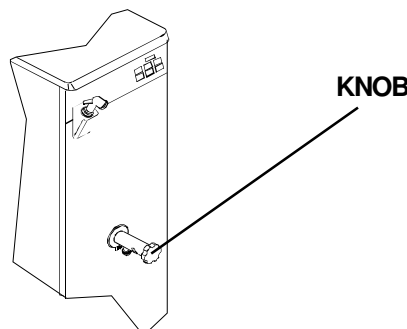

*Note: After extruding the product, it is necessary to automatically wash the spigot, each time, by pressing the special push-button on the control panel.*



## 4. SAFETY DEVICES

### 4.1 ALARMS ON DISPLAY

The machines EPS XP are provided with a series of safety devices to machine and operators' safeguard.

Every time a safety device trips, a signal of alarm is displayed on the second line of the machine display. Writing on display means that the alarm has occurred. To reset it, it is necessary to press STOP.

Herebelow a list of the said ALARMS.



#### **OPEN**

Cover is Open

When opening the cover, your machine sets at STOP and "OPEN" will be on display. The beater will immediately stop, whereas the compressor and relevant solenoid valve (if a further cooling was required) will keep on running 10" more. If the cover is closed within 10", the beater, alone, will restart, whilst all outputs will be activated after the mentioned 10".

#### **ALARM PR**

Safety pressure switch tripping

After 3 interventions, the machine will set at STOP and "Alarm PR" will be on display.

#### **ALARM PTMC**

Compressor Thermal protection

When the compressor thermal relay trips, the machine sets at STOP and "Alarm PTMC" will be on display.

#### **ALARM RTA**

Beater Thermal protection

When the beater thermal relay trips, the machine sets at STOP and "Alarm RTA" will be on display.

#### **ALARM TES**

Safety thermostat

The display shows "Alarm TES" and your machine sets at STOP.

#### **ALARM TEV**

"TEV" temperature sensor broken or short-circuited.

The display shows "Alarm TEV" and your machine sets at STOP. (excepted Cleaning function, where it will be unchanged). Check TEV temperature sensor and replace it, if need be.

#### **ALARM TER**

"TER" temperature sensor broken or short-circuited.

The display shows "Alarm TER" and your machine sets at STOP. (excepted Cleaning function, where it will be unchanged). Check TER temperature sensor and replace it, if need be.

#### **ALARM TGV**

"TGV" temperature sensor broken or short-circuited.

The display shows "Alarm TGV" and your machine sets at STOP. (excepted Cleaning function, where it will be unchanged). Check TGV temperature sensor and replace it, if need be.

## 4.2 BLACKOUT

Blackout is under CPU control in any Pasteurization cycle.

In particular, if the machine was in:

- Stop or Beating, on power return, it will return to Stop position.
- Pasteurization Heating (65°C - 85°C - 90°C): on power return, the machine will return to Heating and will set the stored set value.
- Pasteurization Cooling and unreached Cooling set (4°C): on power return, the machine will set back at Cooling.
- Pasteurization Cooling and Cooling set reached (4°C) and TEV > 15°C: on power return, the machine will set back at Cooling.
- Pasteurization Cooling and Cooling set reached (4°C) and TEV > 15°C: on power return, the machine will set back at Heating and will execute the Pasteurization cycle again.
- During the 30 minute pause: on power return, the 30 minute timer will restart.
- Cooling (manual mode) with temperature over 15°C: on power return, the machine will set back at cooling mode.

## 5. CLEAN OUT, DISASSEMBLING AND REASSEMBLING OF PARTS IN CONTACT WITH PRODUCT

### IMPORTANT

*Cleaning and sanitizing must be carried out at the end of every working day with utmost care in order to guarantee quality of production in the respect of all hygienic rules.*

### 5.1 EXTERIOR CLEAN OUT

Eliminate dust from your machine and also the protective film which, before delivery, it was covered with.

Use water, only, with addition of a mild soap-detergent and a soft cloth, if need be.

#### WARNING

**Do not use solvents, alchools or detergents that can damage the machine parts or pollute those parts involved in the production.**

### 5.2 PRELIMINARY CLEAN OUT

With machine off and **STOP** led on, make sure that the mix dispensing tap is closed; pour thence water into the tank, according to the quantity necessary for the machine wash, by pressing "**shower**" push-button and adjusting the wash nozzle.

Press the "**beating**" push-button and leave in that position a few minutes.

Press "**stop**" push-button.

Drain all water from the tank through the mix dispensing spigot.

Disassemble then the machine by removing its parts.

### 5.3 DISASSEMBLING THE SPIGOT PISTON

Disassemble the spigot by turning the knob (pos. 450) anticlockwise and keeping the plug (pos. 924).

Also remove all other spigot parts.

Thoroughly wash all parts in water with a sanitizing solution and the brush in your kit, then rinse.

Reassemble the whole.

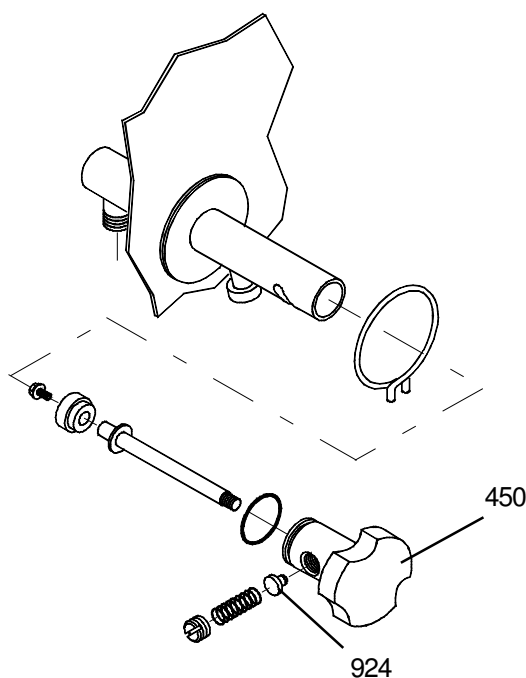

## 5.4 DISASSEMBLING OF TANK COVER



**Note:** The machine is provided with a safety device on its cover; every time you lift the cover while the machine is running, the machine will stop (See *ALARM OPEN*).



The tank cover is completely removable, whereas the hinges are fastened to the machine. Place the cover vertically; deeply push on cover until a pin comes out.

Withdraw the cover by lifting it vertically and pushing forward on the fixed hinges.

Wash in water and cleansing solution, then rinse.

Dip the cover in water and sanitizer, thence rinse. Reassemble the cover.

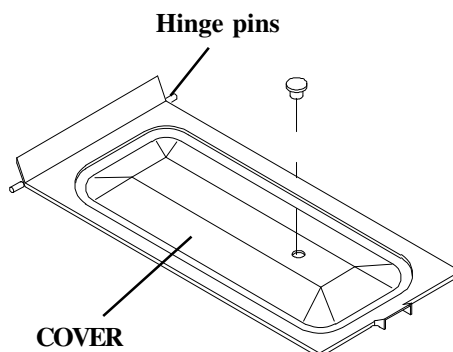

## 5.5 DISASSEMBLING THE BEATER

Remove the BEATER by slightly pulling upwards and minding not to damage the blades.

---

### WARNING

Act with utmost care, as a fall to the ground might damage the beater.

---

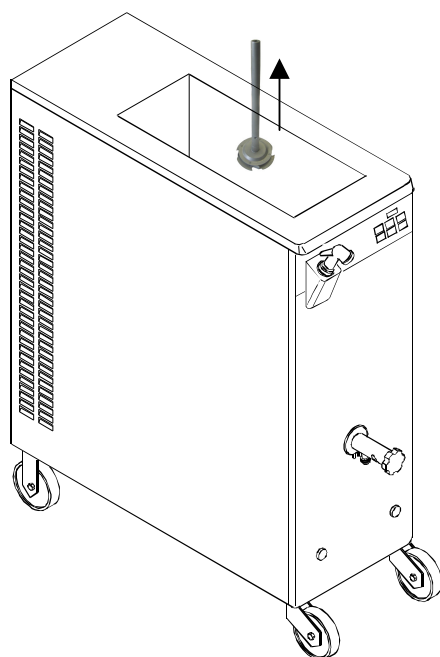

## 5.6 HYGIENE

Mix fat contents are ideal fields for proliferation of mildew and bacteria.

To eliminate them, parts in contact with mixes and creams must be thoroughly washed and cleaned.

Stainless steel materials as well as plastic and rubber ones used for the construction of these parts and their particular design make cleaning easy, but cannot prevent the growth of mildew and bacteria if not properly cleaned.



## 5.7 SANITIZATION

With machine off, after reassembling the beater and checking that spigot pos. 505 is closed, fill the tank with a NON CORROSIVE sanitizing solution.

Press the button "**beating**" and let the beater run one minute.

Press STOP and leave the solution 10 minutes into the machine.



---

### WARNING

**Too a long running in "BEATING" position with empty tank or just filled with water and sanitizing solution, brings about a quick wear of the beater.**

---



Drain all sanitizing solution by opening the spigot.

---

### ATTENTION

**Do not touch the sanitized parts with hands, napkins, or else.**

---



### WARNING

**Before starting again with production, rinse thoroughly with sterile water, in order to remove any residue of sanitizing solution.**

---





## 6. MAINTENANCE

### 6.1 SERVICING TYPOLOGY

#### ATTENTION

**Any servicing operation requiring the opening of machine panels must be carried out with machine set to stop and disconnected from main switch!**

**Cleaning and lubricating moving parts is forbidden!**

**Repairs of electrical and freezing plants must be carried out by skilled engineers!**



Operations necessary to proper machine running are such that most of servicing is completed during production cycle.

Servicing operations, such as cleaning of parts in contact with the product, replacing of stuffing box, disassembling of beater assembly are to be carried out at the end of a working day, so as to speed up serving operations required.

Herebelow you can find a list of routine servicing operations:

**- Cleanout of tank and cover**

At the end of every working day

**- Cleanout of beater assembly**

At the end of a working day

**- Cleanout of panels**

To be carried out daily with neutral soap, seeing to it that no cleansing solution reaches the beater assembly at its inside.

**- Cleanout and sanitization**

At the end of every working day, according to procedures described in section 5.

#### WARNING

**Never use abrasive sponges to clean machine and its parts, as you might scratch their surfaces.**



### 6.2 WATERCOOLING

By machines with watercooled condenser, water must be drained from condenser at the end of selling season in order to avoid troubles in the event that the machine is stored in rooms where temperature may fall under 0°C.

- After closing water inlet pipe, disconnect the drain pipe from its seat and let water flow out from circuit.

### 6.3 AIRCOOLING

Clean the air filter, periodically, in order to remove dust and impurities that may hinder air circulation to the condenser.

Use a brush with long bristles or a bolt of compressed air.

#### ATTENTION!

**When using compressed air, put on personal protections in order to avoid accidents; wear protective glasses!**

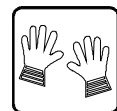

**NEVER USE SHARP METAL OBJECTS TO CARRY OUT THIS OPERATION. GOOD WORKING OF A FREEZING PLANT MOSTLY DEPENDS ON CLEANING OF CONDENSER.**

### 6.4 ORDERING SPARE PARTS

In the event of breaking or wear of one or more parts, request the new ones directly to a Coldelite Engineer, always detailing machine type and serial number printed on data plate you will find on the rear of the machine.

## 6.5 TABLE OF EQUIPMENT

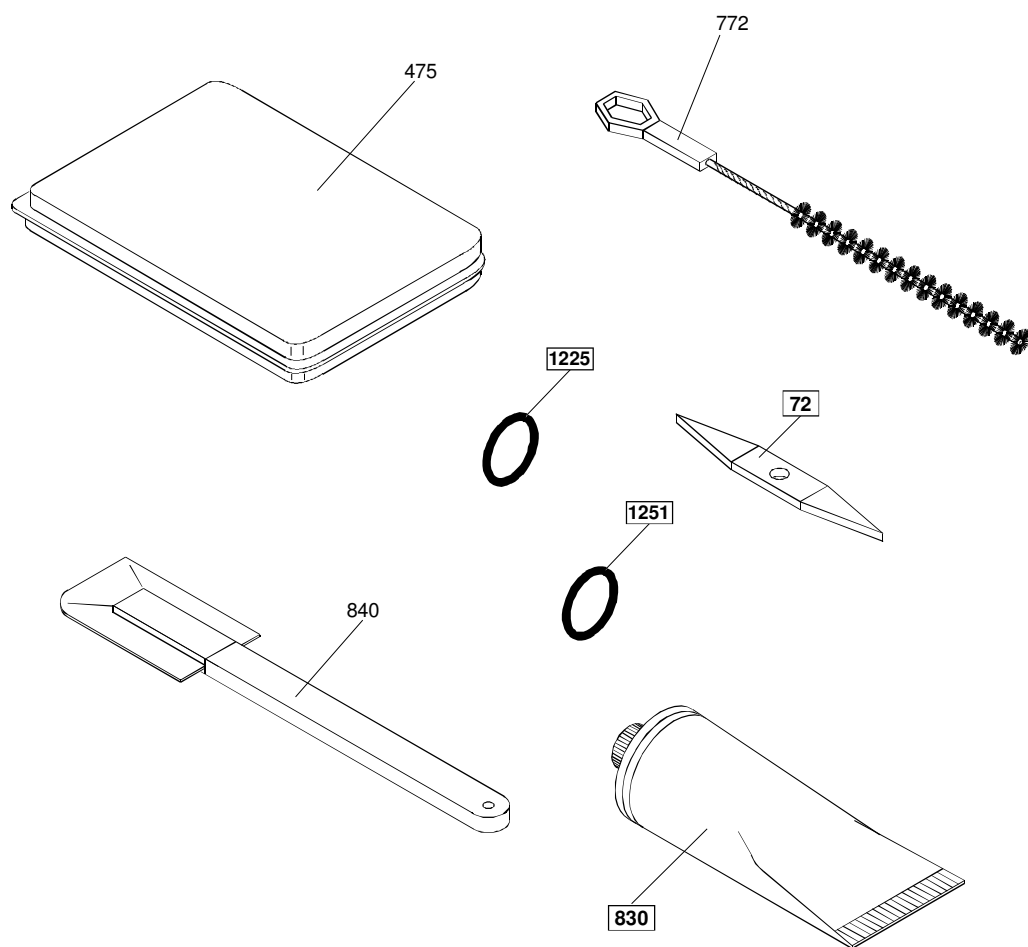

Description	Position Nr
OR extractor	72
Blister	475
Swab D 30x640	772
Food-grade lubricant tube	830
Brush	840
OR	1225
OR	1251

## 7. TROUBLESHOOT GUIDE

TROUBLE	CAUSE	CURE
<b>Machine does not start</b>	The main switch is off	Turn it on
	Machine is unplugged	Check and plug in
<b>Control unit does not accept a control</b>	Control unit	Replace the control unit
		Call after-sale service
<b>Product coming out from dispensing spigot</b>	Gasket is strained, cut, etc.,	Check and replace through a new one
<b>Inside noise</b>	Motor or compressor	Call after-sale service
<b>Bacteria test shows too high level</b>	Too many bacteria in the mix	Improve preparation procedure, by sanitizing all containers, spoons, etc.
	Machine not clean and sanitized enough	Empty and clean the the machine with care. Sanitize as per section 5.