

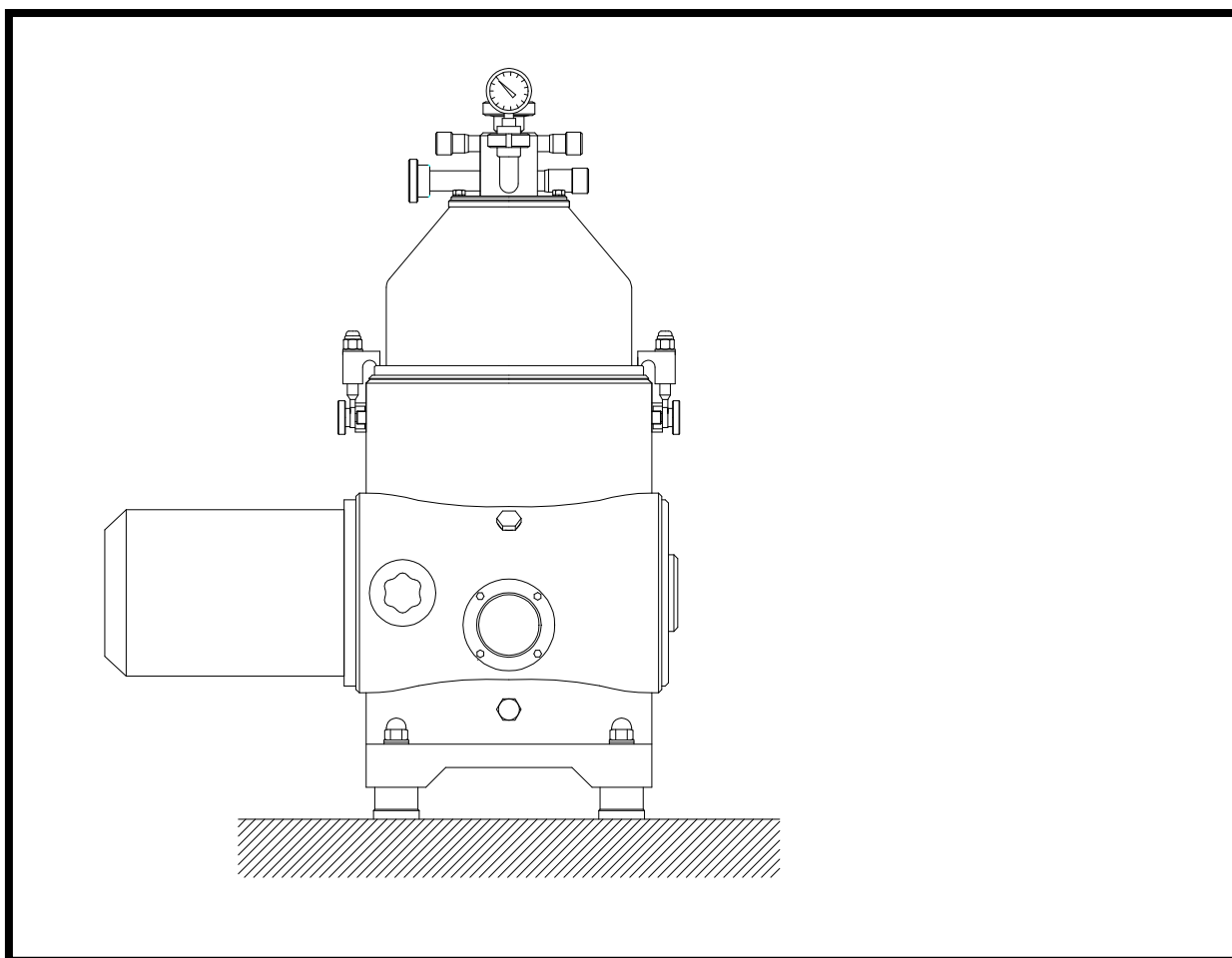

CENTRIFUGAL SEPARATOR SE 07X

USE AND MAINTENANCE HANDBOOK



36014 SANTORSO (VI) ~ Via delle prese n. 14
Tel. ++39/0445/540232 r.a.
Telefax ++39/0445/540214

USE AND MAINTENANCE HANDBOOK

Centrifugal Separator SE 07X

1. HANDBOOK USE

1.1. How to read the Handbook

This handbook gives information for the installation, use and maintenance of centrifugal separator, model SE 07, for milk skimming, standardization, cleaning and whey skimming. The machine must be used in accordance with the Handbook specification: it is recommended to read it with great attention before installing and setting at work the machine, without leaving out anyone of the prescriptions reported and paying particular attention to the messages in the “text squares”. The respect of the reported rules and recommendations permit a safe use and appropriate service.

The use and maintenance Handbook is an integrant part of the machine: it's necessary to conserve it complete and in a safe place during all the machine life, also when changing the machine user.

1.2. How to bring up-to-date the Handbook

It is recommended to bring constantly up-to-date this Handbook, integrating with eventual other amendments, additions or modifications coming from the manufacturer.

It's better that eventual annotations and remarks are inserted only in the space intentionally predisposed at the end of this Handbook.

1.3. Handbook index

1.	<u>HANDBOOK USE</u>	1-1
1.1.	HOW TO READ THE HANDBOOK.....	1-1
1.2.	HOW TO BRING UP-TO-DATE THE HANDBOOK.....	1-1
1.3.	HANDBOOK INDEX	1-2
2.	<u>GENERAL INFORMATION</u>	2-1
2.1.	MANUFACTURER AND MACHINE DATA.....	2-1
2.2.	TECHNICAL SERVICE	2-1
2.3.	GLOBAL ASPECTS OF SAFETY	2-1
2.3.1.	INSTALLATION	2-1
2.3.2.	WARNINGS FOR THE OPERATORS.....	2-1
2.3.3.	MAINTENANCE PROGRAMS.....	2-2
2.3.4.	INVOLVED OPERATORS AND TECHNICIANS.....	2-2
2.3.5.	MAIN WORKING MODES.....	2-2
2.3.6.	FORESEEABLE ERRORS AND INCORRECT BEHAVIORS	2-3
2.3.7.	LIST OF USED SYMBOLS AND WARNINGS	2-3
2.3.8.	SAFETY PRESCRIPTIONS.....	2-3
2.4.	USED TERMS AND ABBREVIATIONS.....	2-6
2.5.	RESPONSIBILITY	2-6
3.	<u>MACHINE DESCRIPTION</u>	3-1
3.1.	GENERAL DESCRIPTION	3-1
3.2.	OPERATING PRINCIPLES.....	3-1
3.3.	TECHNICAL CARD	3-3
3.4.	NOISE LEVEL	3-4
3.5.	DESTINATION AND FORESEEN PLACE OF USE.....	3-4
3.6.	IMPROPER USES AND CONTRA-INDICATIONS	3-4
4.	<u>LIFTING, TRANSPORT, STORAGE</u>	4-1
4.1.	MACHINE DELIVERY	4-1
4.2.	PACKING AND UNPACKING.....	4-1
4.3.	LIFTING AND TRANSPORT OF THE PACKED MACHINE	4-1
4.4.	LIFTING AND TRANSPORT OF THE MACHINE WITHOUT PACKING	4-2
4.5.	WAREHOUSE STORAGE.....	4-4
5.	<u>INSTALLATION/PREPARATION TO START</u>	5-1
5.1.	ENVIRONMENT	5-1
5.2.	WORKING NECESSARY SPACE	5-2
5.3.	EQUIPMENT	5-2
5.4.	LOCATION AND ASSEMBLY ON PLACE	5-2
5.5.	LUBRICATION.....	5-3
5.5.1.	BEARINGS AND GEARS LUBRICATION	5-3
5.5.2.	LUBRICATION OF THREADS AND CONTACT SURFACES OF THE BOWL PARTS	5-4
5.6.	SYSTEMS CONNECTION.....	5-5
5.6.1.	ELECTRICAL SYSTEM CONNECTION	5-5
5.6.2.	SEPARATOR HYDRAULIC FEEDING.....	5-7

6.	BOWL AND INLET-OUTLET FLOW UNIT	6-1
6.1.	BOWL ASSEMBLY	6-1
6.2.	INLET-OUTLET FLOW UNIT ASSEMBLY	6-6
6.3.	ADJUSTMENT OF PUMPS POSITION	6-8
6.4.	INLET-OUTLET FLOW UNIT DISASSEMBLY	6-8
6.5.	BOWL DISASSEMBLY	6-9
7.	MACHINE START	7-1
7.1.	WARNINGS	7-1
7.2.	SAFETY SYSTEMS DESCRIPTION	7-1
7.2.1.	PROJECT DEVICES	7-1
7.2.2.	SHIELDS	7-1
7.2.3.	WARNING BILL-STICKINGS	7-1
7.3.	REGULATION AND CONTROL DEVICES	7-3
7.4.	STOP OF SEPARATOR	7-3
7.5.	ENERGY SOURCES DISCONNECTION	7-3
7.6.	PRELIMINARY CHECKS	7-4
7.7.	STARTING UP INSTRUCTIONS	7-4
8.	MACHINE USE	8-1
8.1.	PERSONNEL TASKS	8-1
8.2.	SET-UP AND ADJUSTMENTS	8-1
8.2.1.	WARNINGS	8-2
8.2.2.	FIRST SETTING	8-2
8.2.3.	SKIMMING MILK OR WHEY	8-3
8.2.4.	PARTIAL MILK SKIMMING (STANDARDIZATION).....	8-3
8.2.5.	MILK CLEANING	8-3
8.3.	ORDINARY MAINTENANCE	8-3
8.4.	SEPARATOR CHEMICAL CLEANING	8-4
9.	GEAR	9-1
9.1.	DISASSEMBLY OF VERTICAL SHAFT (TAB 06).....	9-1
9.2.	ASSEMBLY OF VERTICAL SHAFT (TAB 06)	9-1
9.3.	DISASSEMBLY OF HORIZONTAL SHAFT (TAB 07).....	9-2
9.4.	ASSEMBLY OF HORIZONTAL SHAFT (TAB 07)	9-3
10.	MAINTENANCE	10-1
10.1.	REMARKS	10-1
10.2.	CORRECTIVE AND PREVENTIVE MAINTENANCE	10-1
10.3.	TROUBLESHOOTING	10-3
11.	DEACTIVATION/RESALE	11-1
11.1.	DISASSEMBLY/SCRAPPING.....	11-1
11.2.	COMPONENTS AND MATERIALS ELIMINATION	11-1
11.3.	RESALE.....	11-1
12.	SPARE PARTS	12-1
13.	DRAWINGS AND DIAGRAMS	13-1

2. GENERAL INFORMATION

2.1. Manufacturer and machine data

Manufacturer: SEITAL S.r.l.
Via delle Prese, 14
36014 Santorso (VI) - ITALY
tel. ++39/0445/540232
fax ++39/0445/540214

Machine: Model SE 07

Description: Machine for milk skimming, standardization, cleaning and whey skimming.

Manufacturing machine N.: _____

Manufacturing bowl N.: _____

Manufacturing year: _____

2.2. Technical service

The routine and extraordinary maintenance must be performed in accordance with the instructions of this Handbook. For the cases not considered and for every kind of assistance, it's recommended to directly contact the manufacturer with reference to the data reported on the plate fixed on the machine frame:

- Machine model
- Manufacturing N.
- Manufacturing year

The correct reference guarantee fast and precise answers.

In case the machine maintenance has been made not in conformity with the provided instructions, with not original spare parts or without written authorization of the manufacturer, or in a manner that compromise the integrity or modify the characteristics of the machine, SEITAL will consider itself exempted from every responsibility regarding people safety and the defective working of the machine. Every unauthorized intervention invalidate the guarantee contractually defined.

2.3. Global aspects of safety

This chapter describes the safety and prevention measures due to the user.

2.3.1. Installation

For the installation and environmental cautions refer to Chapter 5.

2.3.2. Warnings for the operators

The user has the responsibility of the diffusion to every operator of this Handbook contents. Besides, it's to the user provide to the necessary training of the technicians employed in machine operation and maintenance, verifying their fitness to the required job.

2.3.3. Maintenance programs

For a machine correct working it's necessary to follow the use, cleaning and routine maintenance prescriptions, as well as the indications regarding preventive, corrective and scheduled maintenance reported at the § 10.2 of this Handbook.

2.3.4. Involved operators and technicians

List of the qualifications of employed personnel.

Simple operator

Perform the functions needed for the normal working of the machine:

- working efficiency control and adjusting by manual valves, good operation check;
- execution of cleaning cycle;
- interventions that involve small disassemblies, as gaskets replacements of external ducts, etc.;
- lubricant oil change and check.

Mechanical technician

He operates when relevant machine disassemblies are necessary or in case of an evident trouble. He performs every mechanical repair/regulation, but doesn't operate on electrical systems under voltage.

Electrician

He operates in every working condition and at every protection level. He performs every repair/regulation of electrical systems, also when voltage is present, respecting the specific safety standards.

2.3.5. Main working modes

Normal operation

Prescribed state:	Mounted shields, all safety devices connected.
Forbidden state:	Safety devices disconnected, supplies sectioned.
Type and number of employers:	one, operator.
Residual risks:	none

Extraordinary maintenance (mechanical intervention)

Prescribed state:	electrical supply sectioned and blocked,
Forbidden state:	supplies not sectioned.
Type and number of employers:	max. two, qualified mechanical technician.
Residual risks:	none.

Extraordinary maintenance (electrical intervention)

Prescribed state:	supplies not sectioned
Forbidden state:	electrician not qualified, removed shields, two operators
Type and number of employers:	one, qualified electrician.
Residual risks:	danger of electrocution due to terminals voltage inside the electric panel.

2.3.6. Foreseeable errors and incorrect behaviors

To avoid eventual errors and/or mistakes, it's necessary that operating procedures and danger warnings reported in this Handbook, are well known from the whole personnel.

2.3.7. List of used symbols and warnings

The symbols used as stickers on the machine, to point out the dangers during use and maintenance are described at § 7.2.3.

In the following pages of the Handbook the relevant information regarding safety are shown into suitable square with the notice "ATTENTION".

ATTENTION

This notice want to recall the attention of the reader on danger zones or movements.

2.3.8. Safety prescriptions

In the following pages are indicated the important safety precautions to observe in machine use.

General prescriptions:

- a) Cure the operating space around the machine, which must be free from obstacles, clean and adequately lighted.
- b) Every machine intervention must be performed by authorized personnel and with the prescribed operators number.
- c) Eliminate every dangerous condition for safety before using the machine and always inform the maintenance responsible about any eventual working trouble.
- d) It is forbidden productive operation with safety devices disconnected or fixed shields removed.
- e) Do not let the machine with disassembled shields.
- f) It is forbidden any modification for adjustment of objects/devices not provided by the manufacturer. Use only SEITAL spare parts.
- g) **Do not execute weldings and flame heating on the bowl parts.**
- h) Never use the machine if damaged.
- i) To guarantee the safety and correct working of the separator, it must be connected only with power and control panel specifically supplied by SEITAL.
- j) In case power and control panel has not been supplied with separator, and electrical connection has been made not in conformity with the instructions reported on enclosed wiring diagram, SEITAL will consider itself exempted from every responsibility regarding people safety and the defective working of the machine.
- k) The electric panel must always be closed.
- l) The key to open electric panel must be entrusted to a specialized and learned person or to a responsible of the department in which the machine works.
- m) Before initial start-up perform every check reported in § 7.6.
- n) The maximum operating speed allowed for the bowl is 8.000 r.p.m.
- o) Never transport or lift the separator with its bowl installed.
- p) Never mount the machine.

- q) Always carry out chemical cleaning at the working end and, in case of long dwell, clean bowl carefully (see § 5.5.1).
- r) If unusual vibration occurs:
- increase immediately the liquid feed (product or water) to a maximum;
 - switch off the motor, but leave the program control on;
 - apply the brake;
 - after the bowl has stopped completely, dismantle, clean and check all parts carefully;
 - evaluate all the possible causes of troubles reported in § 10.3.6;
 - do not operate until the cause of vibration has been located and eliminated.

ATTENTION

Do not disassemble any part of the separator or of the inlet-outlet flow unit before the bowl is completely standstill.

CHECK THE BOWL MOTION STATE LOOKING THROUGH THE CIRCULAR SIGHT GLASS OBTAINED ON THE FRAME (see fig 2.1).

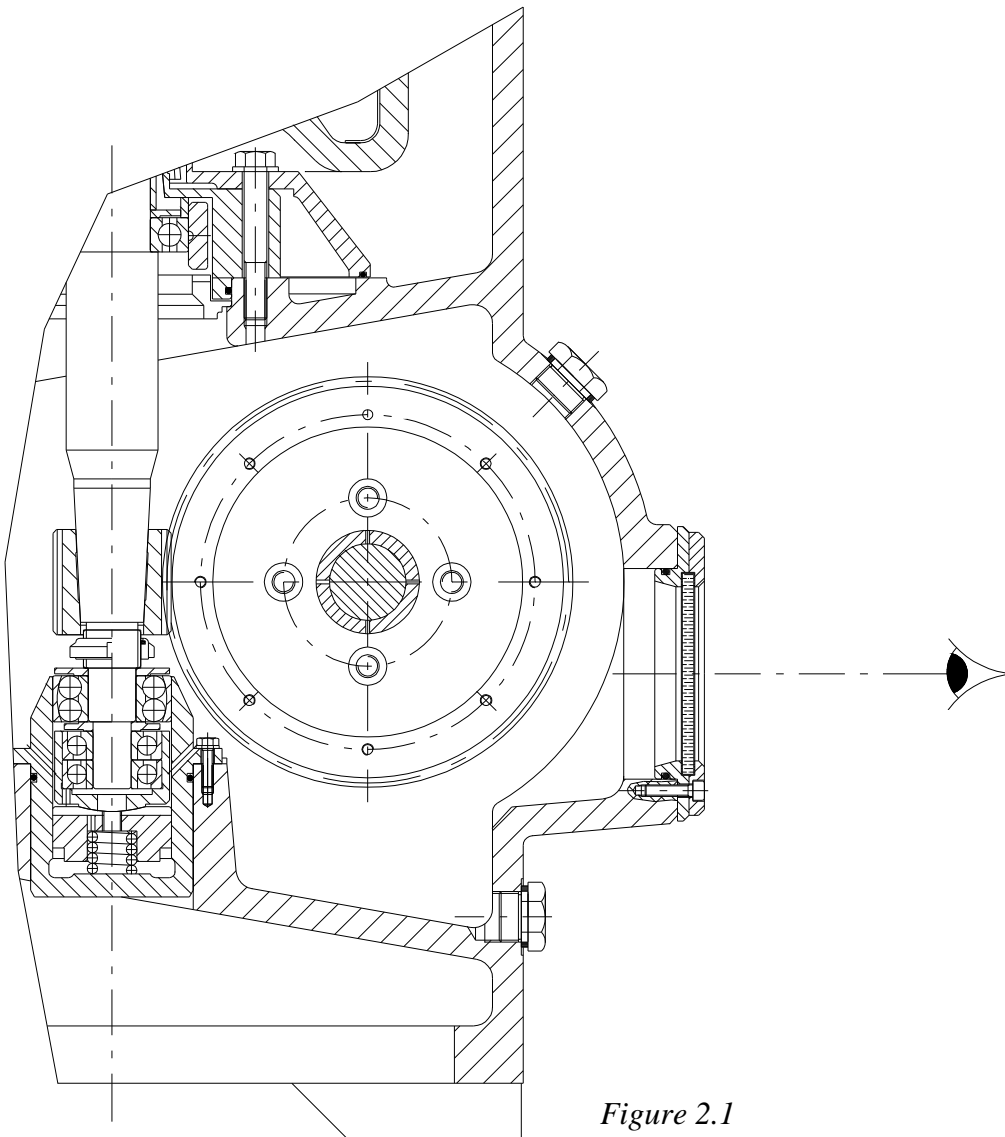

Figure 2.1

Safety prescriptions for mechanical technician

- a) To prevent unbalances that can lead to serious damages, the user must follow the assembly with the most care and avoid shocks and stresses on the separator parts.
- b) Do not allow to unauthorized personnel to work on the machine.
- c) After every maintenance intervention or regulation be sure that tools or other extraneous bodies are not present in the machine moving parts, to avoid damages to the machine and/or troubles to the personnel.
- d) Never insert the body, limbs or fingers in the articulated or sharp opening of machine parts without shields.
- e) Do not use gasoline or inflammable solvents like detergent, but always use authorized, not inflammable and not toxic commercial solvents.
- f) Periodically check the erosion/corrosion of the bowl and consult SEITAL SERVICE if one or more of the following observations are made after a deep check:

- the largest depth of the trace exceeds 1 mm,
- the bottom radius of the erosion trace is less than 1 mm in the narrowest point, or coarse scratches are present,
- defects presumably caused by corrosion are present.

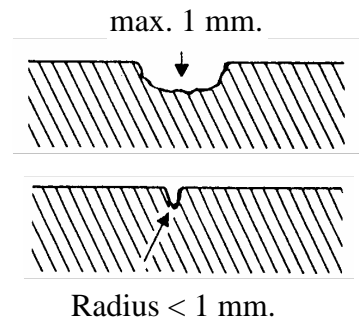

Figure 2.2

Safety prescriptions for the electrician

- a) Check efficiency of earthing connections and be sure they are realized in accordance with local regulations.
- b) Before every intervention on electrical components, verify the supply mains are disconnected.
- c) In case of accident due to electric current immediately cut the supply to electric mains then disjoin the injured (usually he lose consciousness) from the parts under voltage. If this needs an excessive time, drive away the injured using insulating material as a wood or pvc stick, cloth, leather.

ATTENTION
Electrocution danger
This procedure is dangerous: touch the injured means to be struck by lightning.

2.4. Used terms and abbreviations

The measurement units adopted in this Handbook are in conformity with the International System of measurement units SI.

Terms not used currently and present in this Handbook.

- Light phase: liquid obtained in separation, having density lower than the inlet product. In this case the light phase is the cream.
- Heavy phase: liquid obtained in separation, having density higher than the inlet product. In this case the heavy phase is the skim milk.
- Sludges: solid residuals obtained from separation process. They accumulate in the external part of the bowl called sludge chamber.

2.5. Responsibility

The non conformity to the instructions of this use and maintenance Handbook exempt the manufacturer from every responsibility.

For every date not included or deducible from the following pages, it's recommended to directly consult the manufacturer.

3. MACHINE DESCRIPTION

3.1. General description

The SE 07 is a centrifugal separator for milk skimming, standardization, cleaning and whey skimming.

The machine is constituted by a cast-iron frame, painted or coated by stainless steel, on which are installed the following components:

- two shafts with a couple of helical gears with orthogonal axes, a centrifugal clutch, ball bearings, etc.
- motor
- manual brake
- tachometer
- sight glass to check the bowl motion state
- oil gauge glass to check the oil level
- bowl
- bowl protection cover
- inlet-outlet flow unit

The supply includes also a set of special spanners for the bowl.

3.2. Operating principles

This machine consent the separation of milk into cream and skim milk. The separation takes place in the bowl of the separator, rotating at a speed of 8.000 r.p.m.

The product flows into the bowl through feed pipe (1) and into the distributor (2) it undergoes acceleration until it reaches the bowl rotating speed. The distributor (2) conveys the product to the disks stack (3) where the separation between cream and skim milk takes place. The great number of disks divide the internal space of the bowl into many thin layers which make more efficient the separation. The cream, that is lighter, flows towards the centre of the bowl and leaves the disk assembly via its inner edge. The skim milk is heavier and flows towards the bowl periphery. They rise in the disks stack and reach the two upper chambers of the bowl. Here two fixed centripetal pumps (4-5) convey them under pressure to the outlet pipe lines (6-7). The two pumps are surrounded by rotating cream or skim milk so, even if they are not rotating, they transfers the speed of the liquid into static pressure.

The solids impurities eventually present in milk are collected in the periphery of the bowl (8) where they must be removed manually.

Bowl feeding is carried out through a closed pipe line with outlets of the product under pressure, by means of two centripetal pumps and without seal gaskets between fixed parts and rotating parts. On inlet-outlet pipe lines are inserted valves and instrumentation necessary to control and regulate the separator (micrometric adjusting valves, butterfly valves, sanitary pressure gauge, sample cocks, etc.).

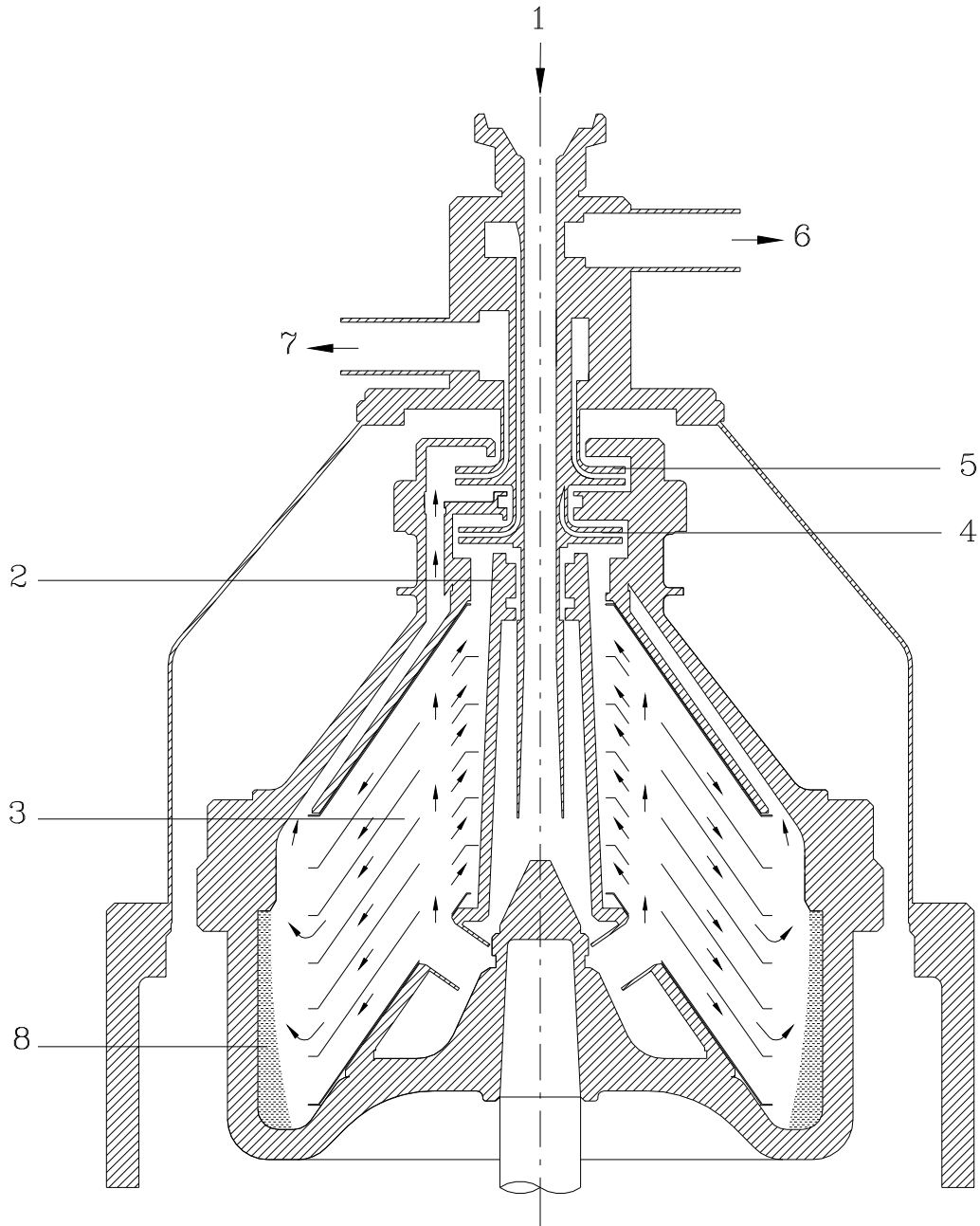

Figure 3.1

- 1 - Feed
- 2 - Distributor
- 3 - Disks stack
- 4 - Cream pump
- 5 - Skim milk pump
- 6 - Cream outlet
- 7 - Skim milk outlet
- 8 - Solids chamber

3.3. Technical card

Overall dimensions of the complete unit (ref. Tab. 03/A):

Width:	640 mm.
Length:	950 mm.
Height:	1.170 mm.

Weights:

Bowl weight:	80 kg.
Separator weight (without bowl):	450 kg.

Operating features:

*Milk skimming capacity:	3.000 l/h
*Whey skimming, standardization, milk cleaning capacities:	4.500 l/h
Bowl capacity:	7 l
Solids chamber capacity:	3 l
Bowl speed:	8.000 r.p.m.
Motor speed:	1.450 r.p.m.

Product and process features:

Maximum product density:	1,1 kg/dm ³
Maximum sludge density:	1,35 kg/dm ³
Maximum product temperature:	95 °C
Minimum product temperature:	3 °C
*Process temperature:	20 ÷ 60 °C

Electrical system features:

Motor power:	5,5 kW
Voltage:	3 x 400/690 V
Frequency:	50 Hz
System:	three-phase+earth
Motor protection level:	IP 55
Operation:	electro-mechanical

Hydraulic system features:

*Required feeding pressure necessary for a machine working at maximum capacity:	0,5 bar
*Maximum outlet pressure (cream and skim):	3,5 bar

Spacers of inlet-outlet flow unit (§ 6.3):

- n° _____ x thickness _____ mm.
- n° _____ x thickness _____ mm.
- n° _____ x thickness _____ mm.

Total thickness _____ mm.

(*) These data depend on the specific application (milk skimming, standardization, cleaning and whey skimming).

The skimming capacities given above has been obtained with normal milk and whey at a temperature of 30÷50 °C with 0,03 % maximum residual fat content (Gerber system).

3.4. Noise level

The machine has been subjected to a noise emission test with reference to the noise test code included in Annexe A of the standard prEN 12505.

The determination of noise emission values (sound pressure level) has been done with empty machine, rotating at the operating speed. Care has been taken to ensure that the any electrical conduits, piping or air ducts which are connected to the machine do not radiate significant amount of sound energy.

The measurement has been done at 1,0 m. in front of the machine and 1,6 m. above the floor.

A-weighted time-averaged emission sound pressure level: _____ dBA

3.5. Destination and foreseen place of use.

The machine must exclusively operate inside a closed place, which must possess features in conformity with the prescription of this Manual (see § 5.1).

The floor must be plane, without asperities, sufficiently solid to avoid sinkings.

3.6. Improper uses and contra-indications

- Never use the machine to separate liquids which have different characteristics (density, temperature, corrosion, etc.) from those specified.
- The bowl has not to rotate at a higher speed than the maximum operating speed (8.000 rpm).
- The bowl has not to rotate empty. It is allowed to put into rotation the empty bowl for a period of 15 min. only in starting phase.
- Never elude or disactivate the safety shields.
- Never use the machine if it is damaged.
- Use only SEITAL spare parts.

ATTENTION

Avoid water jets on the motor.

Every use different from the specified, not included o deducible from this manual, it is considered "NOT ALLOWED".

4. LIFTING, TRANSPORT, STORAGE

4.1. Machine delivery

The whole material is accurately checked from the manufacturer before the forwarding.

For transport and lifting operation the bowl is separated from the rest of the machine; this to preserve the integrity of the rotating parts of the machine.

When receiving the goods check the machine has not been damaged during transport or that the eventual package has not been tampered with subsequent removal of internal parts. Verify therefore that data desumed from the accompanying documents correspond to forwarding data.

When disassembling it is advised to accurately sieve the packing, to avoid that parts, missing at first sight, are not remained in the packing material.

If damages or missing parts are noticed, immediately inform the carrier and the manufacturer showing photographic documentation.

4.2. Packing and unpacking

The packing conditions are defined with the customer in relation with the distance and the chosen mean of transport. The machine can be transported without packing.

In case of packing this is constituted by a wood box.

The machine parts must be assured to the level ground (by brackets or other) to prevent every horizontal and vertical movement.

The sheets affixed outside the packing contain the following information:

- Manufacturer
- Address
- Gross weight
- Case dimensions
- Means of lifting
- Lifting points

UNPACKING

Carry the packed machine closest the place selected for installation.

Remove the plastic protection to free the machine.

Conditions of packing elimination (if present):

Wood: not pollutant material, to correctly recycle.

Plastic: pollutant material to not burn (toxic fumes) neither waste in the environment; eliminate in accordance with the law in force in the user country.

4.3. Lifting and transport of the packed machine

To lift the packing can be used the following means:

- lift truck;
- bridge crane, crane or hoist with sling.

LIFT TRUCK

Use a lift truck with:

- capacity higher than the weight of the machine+packing (reported outside the case);
- fork with length higher than 1500 mm.

Insert the forks under the level ground in central position, where signed by the suitable triangles on the case (fig. 4.1), and keep them at the maximum distance one from the other.

SLING

Must be used ropes or bands in good conditions (neither damaged nor deteriorated) having guaranteed capacity higher than the weight of the machine+packing (reported outside the case).

Pass the two ropes outside the “case feet” to avoid the sliding of the ropes towards the centre of the case (fig. 4.2).

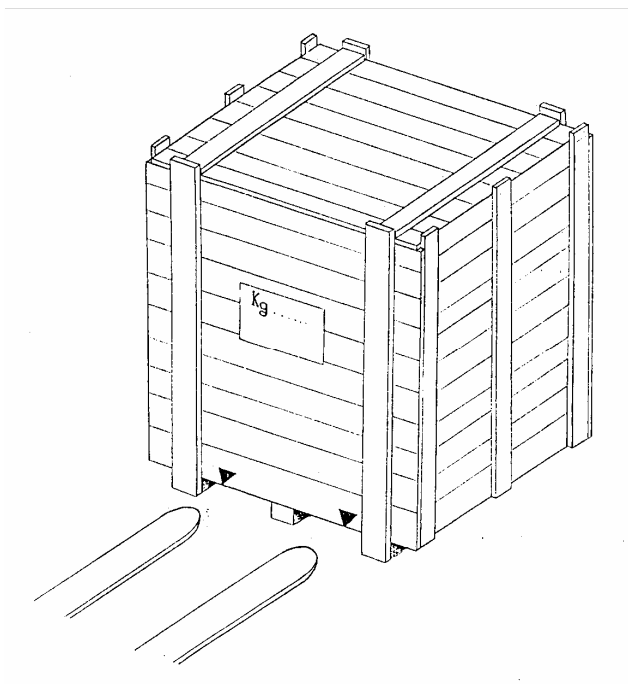

Figure 4.1

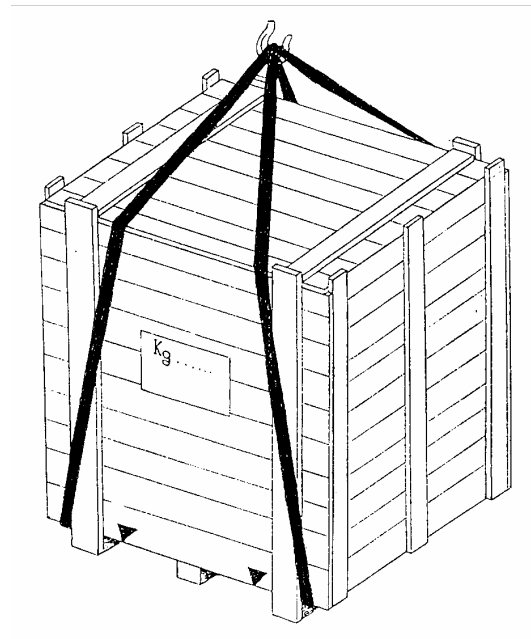

Figure 4.2

4.4. Lifting and transport of the machine without packing

ATTENTION

Danger of damaging the machine during transport

The machine transport on the road must be performed without the bowl to avoid damaging of the vertical shaft and/or ball bearings.

To lift the separator use two hemp ropes and a bridge crane, crane or hoist having guaranteed capacity higher than the weight of the machine (ab. 450 kg.).

Pass the two ropes under the frame, and adjust their length in order to have the lifting point on the center-of-gravity vertical line (one rope must be placed inside the frame foot on motor side, the other one on the opposite side); then lift the whole.

To lift the bowl (fig. 4.3) a particular procedure must be followed:

- open the two ends of the spanner wide apart (part 1);
- insert the middle part of the spanner under the tooth placed at the end of the conical part of the bowl hood (part 2)
- apply on the spanner the lifting ropes having guaranteed capacity higher than the weight of the bowl (ab. 80 kg.)
- lift the whole by hands, with a bridge crane, crane or hoist.

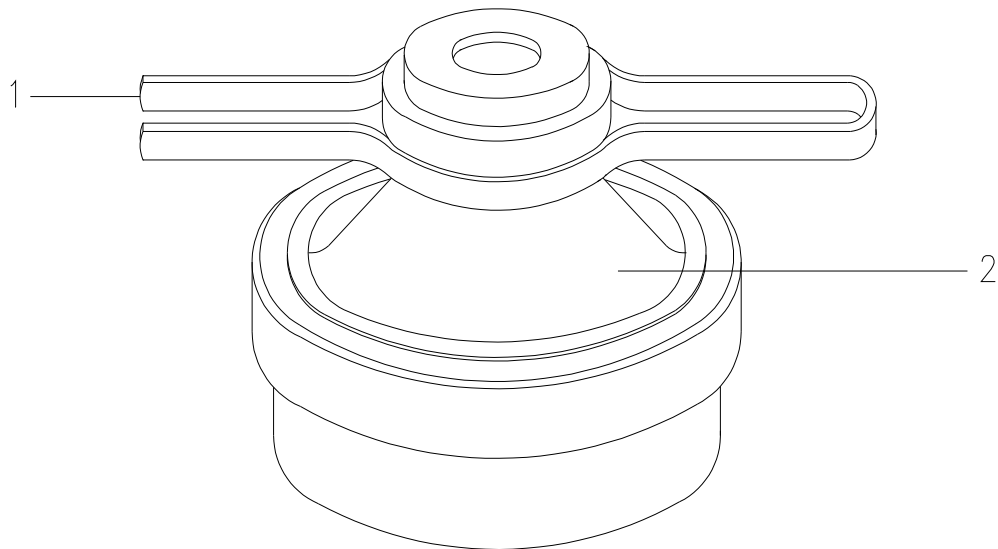

Figure 4.3

ATTENTION

Danger of machine turnover

Danger of impact and squashing for people

During lifting and transport must be used great caution to avoid injury to people and things.

This operation must be performed by expert personnel.

Verify that nobody is exposed to a risk in danger zone.

**WHEN LIFTING ALL THE AREA SURROUNDING THE MACHINE MUST BE
CONSIDERED DANGER ZONE.**

Until the groups (bowl, separator) are not completely lifted it's better to verify the correct balancing of them. The lifting must be performed with continuity (without impulses).

Keep the load lower than possible during movements, both for a better load stability, and for a higher visibility.

The manufacturer does not answer about breakages due to the transport of the machine after the delivery.

All the elements that are potentially moveable or not resistant to his weight must be securely fixed to the machine to prevent dangerous disjunctions or unbalancing.

For the machine not packed is prescribed a covered transport.

4.5. Warehouse storage

The machine storage, with or without packing, must be done in a place which has the humidity and temperature conditions reported in § 5.1.

If the machine remains unused for a long time (more than 3 months), after it has already worked at least once, perform the following operations:

- accurately clean the separator;
- dry with clothes and greased all the bowl parts and the unpainted parts of the machine, to avoid corrosions;
- keep the bowl in a dry place;
- to avoid the gaskets become brittle, preserve them in a cool, dry, dark and dust-sheltered place;
- discharge lubricant oil and accurately clean the gear chamber;
- disconnect the inlet-outlet pipes of the product;

When starting the machine follow the instructions reported in § 7.

5. INSTALLATION/PREPARATION TO START

5.1. Environment

The machine works inside a covered factory, with steady temperature, limitedly exposed to dust and humidity.

Except for different specification in order established, the machine has been designed and tested to regularly work in the environmental conditions reported below.

If the conditions are very unsteady, the means and characteristics of air-conditioning will have to be fixed.

ALTITUDE

The altitude of the place where the machine will be installed have not to be higher than 1000 m from sea level.

TEMPERATURE

Minimum room temperature: +10°C

Maximum room temperature: +40°C

ATMOSPHERIC CONDITIONS

The electric equipment can correctly work in atmospheric conditions with relative humidity not higher than 50% and temperature of 40°C, and at 90% with temperature not higher than 20°C (without condensate).

LIGHTING

The factory lighting system is considered very important for the safety of people and of work quality. It is for the customer to know the standards regarding accident prevention and work health in force in his country. These standards define the responsibilities of the work place manager, who must guarantee a good efficiency of plants and consequently of machines.

In Italy this argument is regulated by a ministerial decree which clearly fix the average level of prescribed lighting.

The lighting is measured in lux (1lux = 1lumen/mq).

Minimum necessary lighting: it has to guarantee the correct perception of symbols and marks (from 300 to 500 lux).

Maximum lighting: it has to avoid the operator dazzling.

ATMOSPHERE WITH EXPLOSION AND/OR FIRE RISK

The standard machine SE 07 is not arranged to work in environments with atmosphere with explosion and/or fire risk.

The customer/user must absolutely specify, during negotiation, if the risk is present.

An environment different from the prescribed one can cause dangerous situation for people.

5.2. Working necessary space

The choice of the place or space suitable for the laying of the machine is important for the quality of the work (maintenance, safety, etc.).

Fix the boundaries of the area for the operator, foreseeing areas sufficient for normal operation, maintenance and release.

The free space will be the space indicated in Tab. 22.

This area must be good-lighted and ventilate.

The environment and operating conditions have not to be a hindrance for the access to the machine controls. The machine operation must be guaranteed, including also the maintenance activities.

5.3. Equipment

The machine normal equipment include:

- Set of special spanners for the bowl.
- Set of spare parts (gaskets, disks, etc.).

5.4. Location and assembly on place

Move the machine without bowl to avoid damaging vertical shaft and/or ball bearings.

To lift separator follow instructions reported § 4.4.

Fix the foundation plate to the floor with its four anchor bolts by means of a concrete casting, making sure that the plane (A) of the four supports is horizontal (fig. 5.1).

Put the four shock absorbers on the foundation plate supports. Lift the frame and put it over the shock absorbers. Check the correct resting of all shock absorbers.

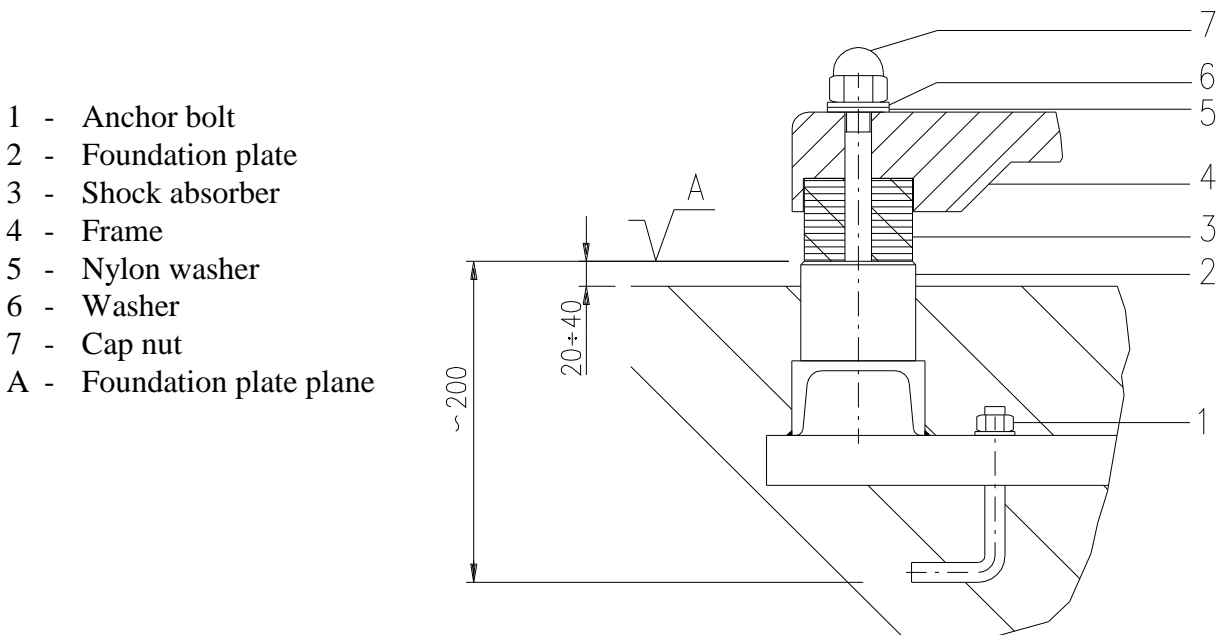

Figure 5.1

The frame plane (B) must be horizontal (fig. 5.2). In order to obtain this, adjust the screwing of cap nuts, which must be screwed without tightening, to have always a good working of the shock absorbers.

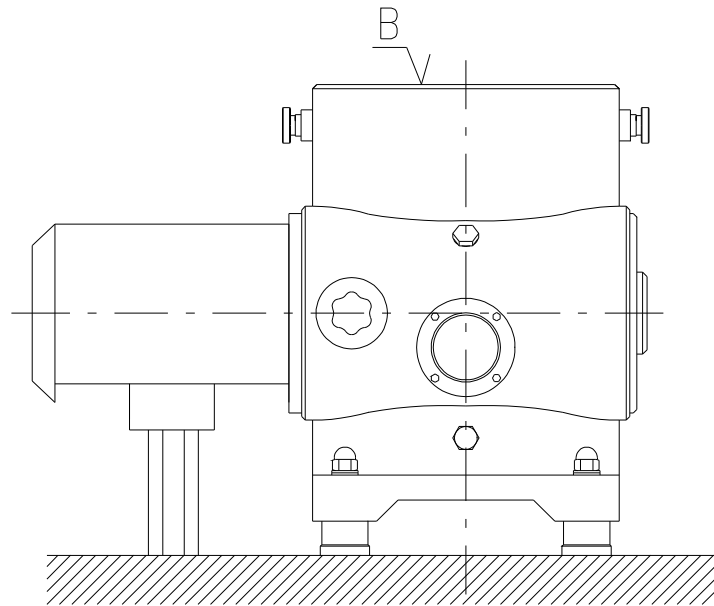

Figure 5.2

5.5. Lubrication

5.5.1. Bearings and gears lubrication

All the separator bearings and gears are splash lubricated.

OIL LEVEL

The separator is delivered without lubricating oil. Before the first starting it is necessary to fill the gear housing with the lubricant of separator equipment. After the filling, the oil must be at a level just over the mark on the sight glass (fig. 5.3). During operation, the oil level has never to fall below the mark.

Check the oil level every day before the starting up and check presence of water from time to time loosening oil drain plug and drawing a sample. If this is “white coffee coloured” (emulsion symptom), change immediately the oil.

- 1 - Oil supply plug
- 2 - Oil drain plug
- 3 - Sight glass
- A - Oil level with standstill separator

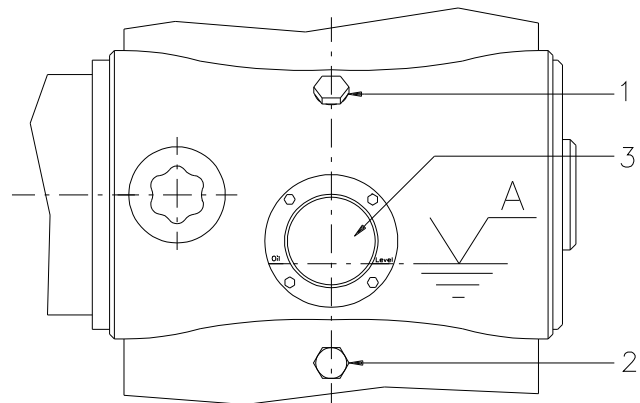

Figure 5.3

ATTENTION**Danger of injury or burning**

It is peremptorily forbidden to perform the oil change or supply when the machine is still rotating.

TYPE OF OIL

Always use mineral, non-corrosive oil EP type with the following characteristics:

Viscosity: - 220 cSt at 40°C, corresponding to ISO VG 220.

- 18,7 cSt at 100°C.

Viscosity index: 95.

Density: 0.895 kg/l, at 15°C.

ATTENTION**Danger of gears and ball bearings damaging.**

It is peremptorily forbidden the use of syntetic oil.

Oil satisfying the previous qualifications:**AGIP Blasia 220**

API DT-220

BP Energol GR-P 220

CASTROL Alpha SP 220

ELF Reductelf SP 220

ESSO Spartan EP 220

GULF EP Lubricant HD 220

IP Mellana oil 220

MOBIL Mobilgear 630

Q8 Goya 220

SHELL Omala oil 220

TAMOIL Carter EP lubricant 220

TEXACO Meropa 220

TOTAL Carter EP 220

OIL CHANGE

The first time change the oil after 300 operating hours and then once every 1500 operating hours; however never let pass a period longer than six months (check the effective working time of the machine, reading the value reported in the hour counter placed inside the electric panel). In seasonal operation the oil change must be performed before every operating period. Whenever changing oil, accurately clean gear housing and remove all metal particles fouled in the internal walls and corners of gear chamber. Do not use downy rags or cotton waste. Clean sight glass.

AFTER LONG REST OF SEPARATOR

After visually checking the condition of gears inside gear housing, it is advisable to change oil and lubricate the upper ball bearing spraying some oil from below.

5.5.2. Lubrication of threads and contact surfaces of the bowl parts

When assembling the bowl it is advised to apply a thin lubricant layer on threads and contact surfaces of bowl components such as: bowl body, bowl hood, lock rings, etc.

It is recommended the use of the following lubricants:

for food industry

- Molykote D (white paste)
- Molykote DX (white paste)
- Kluber Grease KSB 8

for chemical industry

- Molykote G
- Molykote G Rapid

In addition, other pastes or greases with the same properties may be used.

5.6. Systems connection

5.6.1. Electrical system connection

ATTENTION

Electrocution danger

The electrical connection must be performed by the electrician (that is informed about the risks connected to the intervention and knows as avoid them).

The user has to predispose a suitable isolating switch of the electric line upstream the machine, in addition to effective protection advices against overcurrents/indirect contacts.

When connecting:

- Verify that the supply mains is provided with suitable earth connecting system and correspond to the voltage and frequency indicated in the wiring diagram supplied with the machine;
- Perform the connection of separator to electric mains with great caution, according to the connection diagram on the next page (fig. 5.4), without voltage in the mains and respecting the safety prescriptions and local regulations. It's absolutely forbidden the mains connection without grounding.
- It is advisable to install the control panel near the machine, to assure a fast intervention in case of danger.
- The electrical motor of the separator is designed for direct starting.
- Always use waterproof conduits on motor terminal board inlet.
- Before assembling the bowl, check direction of rotation by a "short" motor starting. The correct direction of rotation is indicated by the arrow on separator frame, corresponding to the clockwise rotation of vertical shaft (see from above).
- The electrical power supply of the separator motor must be designed relating to starting current (approximately $1,5 \div 2$ times the nominal current of the motor).

ATTENTION

Generic danger

In case power and control panel has not been supplied with separator, the electrical connection has to be made in conformity with the instructions reported on enclosed wiring diagram and respecting the safety prescriptions and local regulations.

5.6.2. Separator hydraulic feeding

Inlets and outlets are indicated in Tab. 03.

To obtain a regular and efficient working of separator:

- feed the separator with constant flow of product;
- pre-filter the product to process, to prevent the entry of extraneous solids of large size (curdled residues).

It is advisable to connect the separator to the plant by pipes which length is not more than 1 m. to facilitate the disassembly of the connections when dismantling the bowl. Therefore, avoid connections (to another machine, to the wall, etc.) that rigidly constrain the inlet-outlet unit of the machine; this could increase vibrations level.

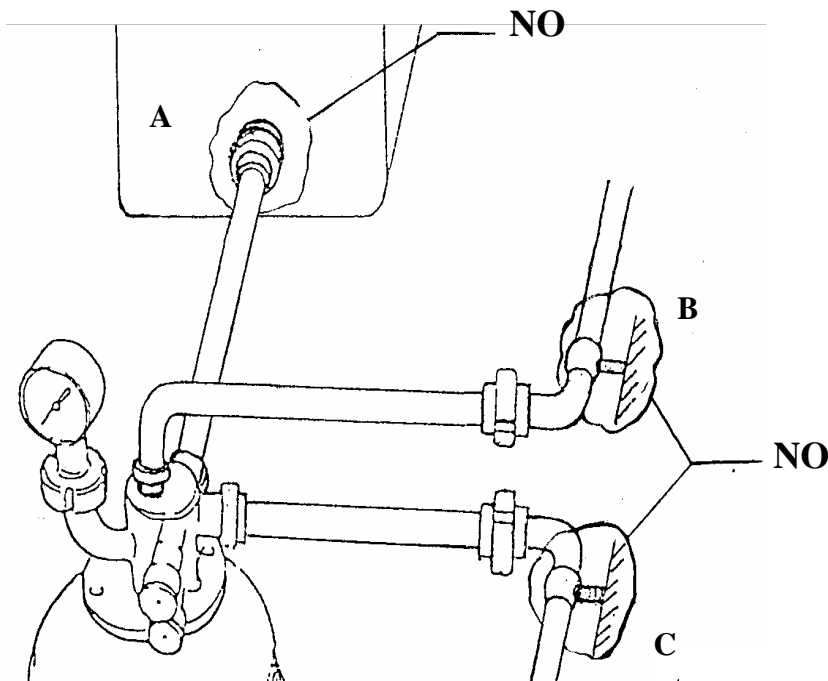

Figure 5.5

The eventually present drain traps (cover discharge, operating water discharge, etc.) have not to be totally connected by pipes, to check eventual leakages (fig. 5.6). These precautions must be adopted to avoid that some liquid (water, product or sludges) could flow in the upper part of the frame braking the rotating bowl and/or drain in the gear chamber damaging the bearings.

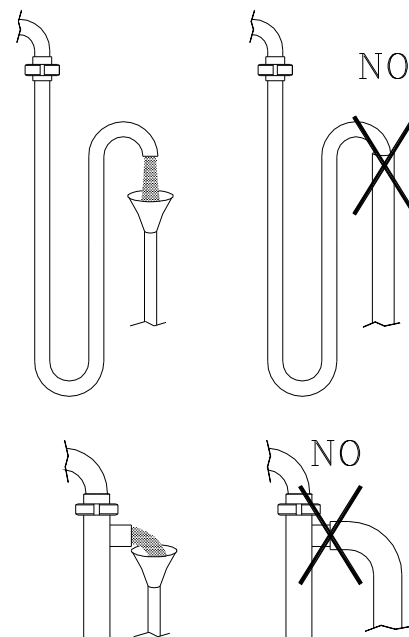

Figure 5.6

6. BOWL AND INLET-OUTLET FLOW UNIT

The bowl is supplied separately from the rest of the machine, so before setting at work the machine, it must be dismantled and assembled on vertical shaft in the frame. The bowl, rotating at high speed, is subjected at high stress that could compromise the operating safety of separator in case the bowl has been improperly assembled and cleaned. In *Figure 6.1* are shown all the main pieces of the bowl.

- 1 - Bowl body
- 2 - Bowl body nut
- 3 - Distributor
- 4 - Bottom disk
- 5 - Intermediate disk
- 6 - Upper finned disk
- 7 - OR gasket - finned disk
- 8 - OR gasket - bowl hood
- 9 - Bowl hood
- 10 - Big lock ring
- 11 - Gasket - dividing disk
- 12 - Dividing disk
- 13 - Finned cover
- 14 - Small lock ring

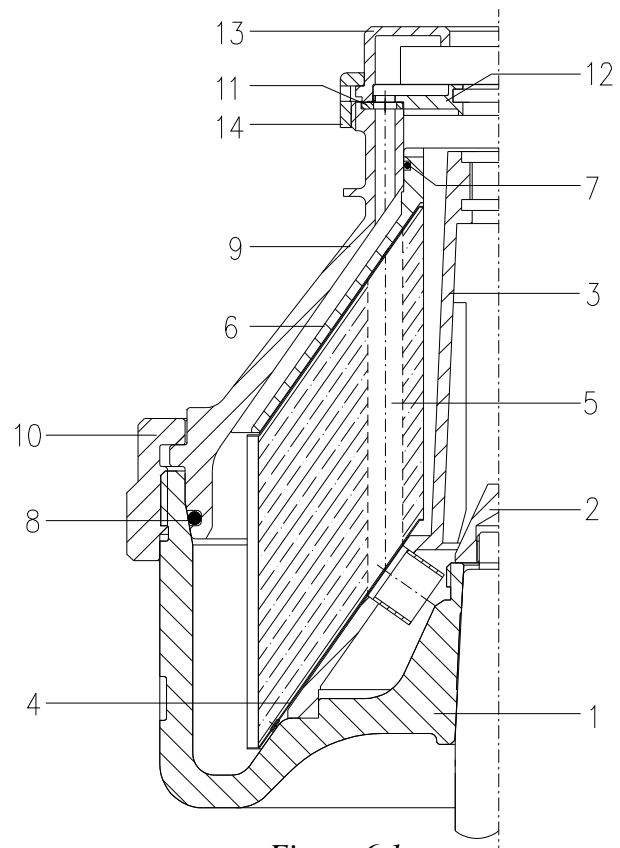

Figure 6.1

6.1. Bowl assembly

In bowl assembly follow in detail the procedure indicated below and pay particular attention to the following warnings:

ATTENTION
Generic danger

The bowl has not to be started before it has been completely assembled.

- Carefully clean coupling surfaces and gaskets groove.
- Smear antiscuff grease on threads and surfaces subject to rub.
- Check presence of all gaskets on new bowl too.
- Every part must be correctly positioned; almost all bowl parts have an angular position fixed by pins or feather keys - except for threaded parts and gaskets (Figure 6.1 - parts 2, 7, 8, 10, 14).
- Bowl body nut and bowl lock rings have left-handed threads.
- Always use our special spanners.

- 1) Clean and wipe dry the conical part of the vertical shaft and carefully clean also the inside of the bowl hub to assure proper fitting.

By the spanner (09.080.0), insert the **bowl body** (fig. 6.2). Follow these indications.

- screw the spanner on the hub of the bowl body
- lift the bowl body by hand or by hoist and place it down with caution on the conical part of the vertical shaft.

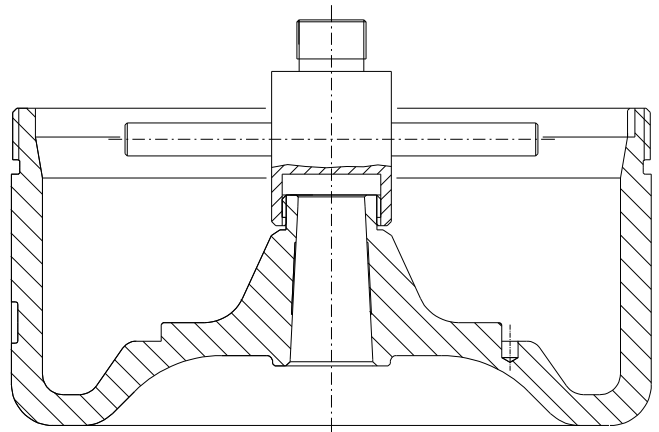

Figure 6.2

- 2) Screw the locking pins to prevent bowl rotation (fig. 6.3).

To do this:

- Check the threaded rod with clamp (3, 4) are in horizontal position.
- Rotate the bowl body until the "0" mark is aligned with one of the two locking pins.
- Screw the first locking pin (6), by turning clockwise the handwheel (2). It fit the circular groove on the bowl body. Do not force the locking.
- Screw the second locking pin without fasten it too much.
- Simultaneously fasten the two handwheel.

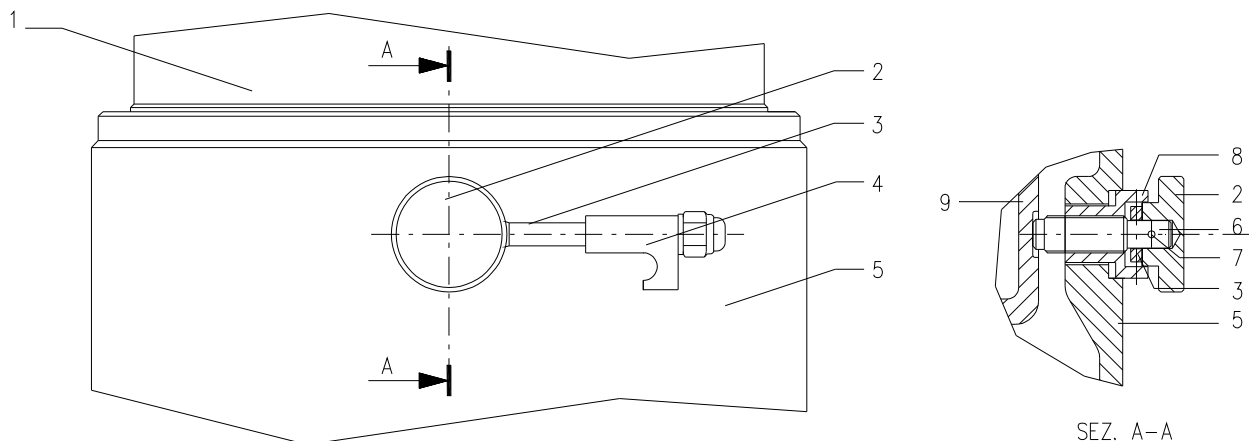

Figure 6.3

- | | |
|------------------|-------------------|
| 1 - Cover | 6 - Locking pin |
| 2 - Handwheel | 7 - Elastic pin |
| 3 - Threaded rod | 8 - Threaded bush |
| 4 - Clamp | 9 - Bowl |
| 5 - Frame | |

- 3) By the suitable spanner (09.040.0), screw tight the **bowl body nut** (part 2 in fig. 6.1). Remind that it has left-handed thread.
- 4) By the spanner (09.080.0) place down the **distributor** (fig. 6.4, part 1), so that the guide pin of the bowl body enter correctly into the corresponding seat in the distributor (fig. 6.4 part 2).

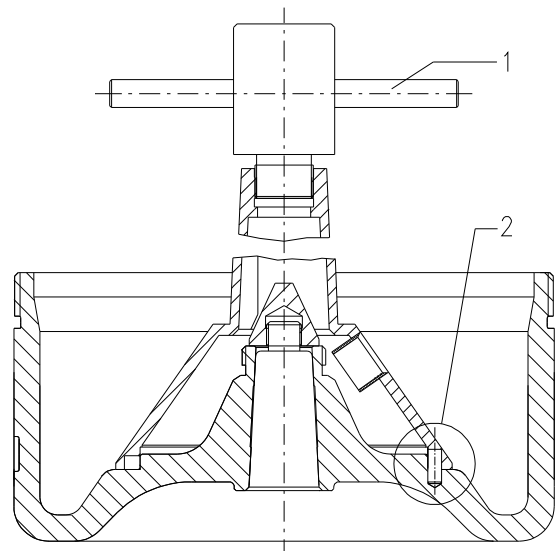

Figure 6.4

- 5) Insert the **disks**. The disks can be inserted in the distributor only in one way. As shown in Fig. 6.5, over the distributor is marked a big “O” that must be aligned with “O” mark of the bowl body. The disk must be inserted in such a way that the small slot made on the internal upper edge of the disk glide on the distributor fin marked with the “O”. Insert at first the **bottom disk** (Fig. 6.1, part 4) that distinguishes itself by having spacers on both surfaces. Then insert the intermediate disk (Fig 6.1, part 5). Take care to not change the sequence of the disks.

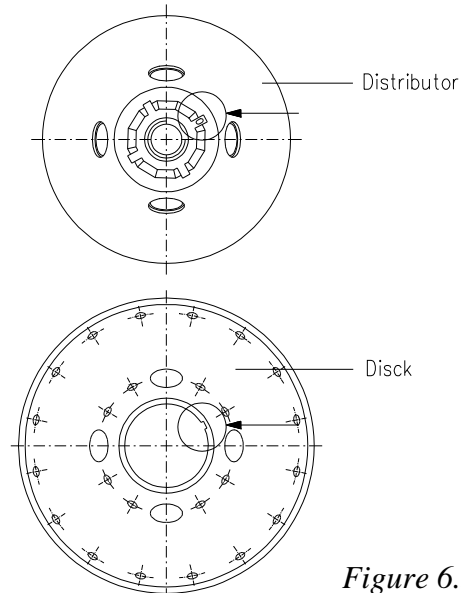

Figure 6.5

- 6) Place down the **upper finned disk** (fig 6.1, part 6) this the last disk to be inserted.
- 7) After carefully cleaning the groove, insert the OR gaskets on upper finned disk (fig 6.1, part 7).
- 8) After carefully cleaning the groove, insert the OR gaskets on bowl hood (fig 6.1, part 8).

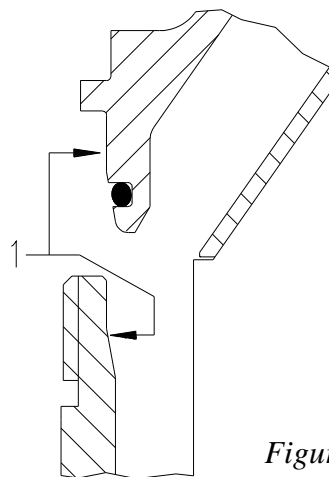

Figure 6.6

9) Carefully clean the conical coupling surfaces of bowl body and bowl hood (fig 6.6); then smear on them a thin film of antiscuff grease (alimentary type).

10) By the spanner (09.010.0), place down the **bowl hood** (fig 6.1 - part 9). Proceed as follows (fig 6.7):

- open the two ends of the spanner wide apart;
- insert the middle part of the spanner under the tooth placed at the end of the conical part of the bowl hood
- gripping by hands the two ends of the spanner, lift the piece and fit it with caution on the bowl body.

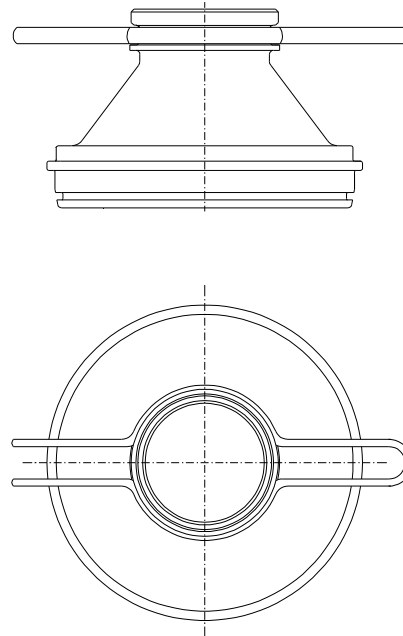

Figure 6.7

11) Smear antiscuff grease on threads of bowl body and big lock ring (fig. 6.8 - part 1) and on contact surfaces between bowl hood and big lock ring (fig. 6.8 - part 2).

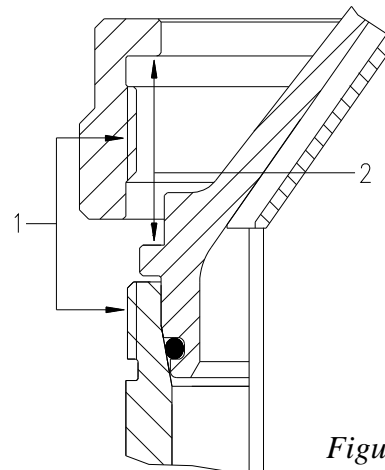

Figure 6.8

12) By the spanner (09.020.0) screw the **big lock ring** (fig 6.1 - part 10) that has left-handed thread. It must be possible screw by hands the ring until the “0” mark is at least 1 cm. before the “0” mark of the bowl body (if this does not happen, it means that the assembly is not correct or the number of disks is wrong). Then fasten it down as much as possible by striking with mallet (09.030.0) the spanner handle. Now the “0” marks must be aligned. In case the bowl is not new and the parts start being worn, the “0” mark of the ring will go beyond the “0” mark of the bowl body. The distance between the two references must not exceed 3 cm.

- 13) After carefully cleaning the groove, insert the **OR gaskets** (fig. 6.9 - part 1) on **feeding pipe** (2) and place it down.
- 14) Apply the three **OR gaskets** (3) in the **cream centripetal pump** (4), and insert it on feeding pipe.
- 15) After carefully cleaning the suitable seat, apply the **gasket of dividing disk** (fig. 6.10 - part 5) on bowl hood top checking that the pin on the bowl hood correctly enter in the suitable hole on the gasket.
- 16) Apply the **dividing disk** (6) aligning the “0” with the “0” of the bowl hood.

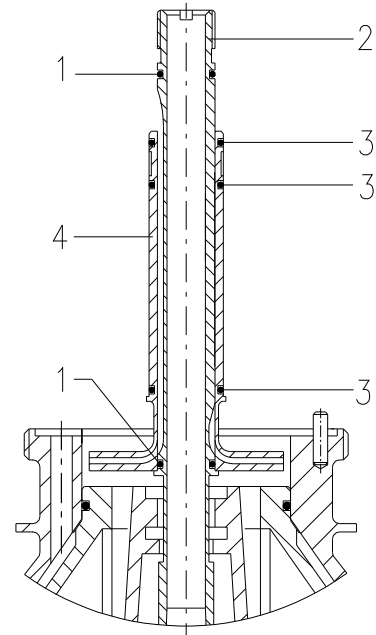

Figure 6.9

- 17) Apply the three **OR gaskets** (7) in the **skim centripetal pump** (8), and insert it on feeding pipe.
- 18) Place the **finned cover** (9), and take care that the “0” marks aligned.
- 19) Using the spanner (09.060.0) and the mallet (09.030.0), screw (left-hand thread) the **small lock ring** (10).
- 20) Unscrew the locking pins (fig. 6.11), by turning anticlockwise the handwheel (5).
- 21) Verify that the bowl is free to rotate, before assembling the cover.

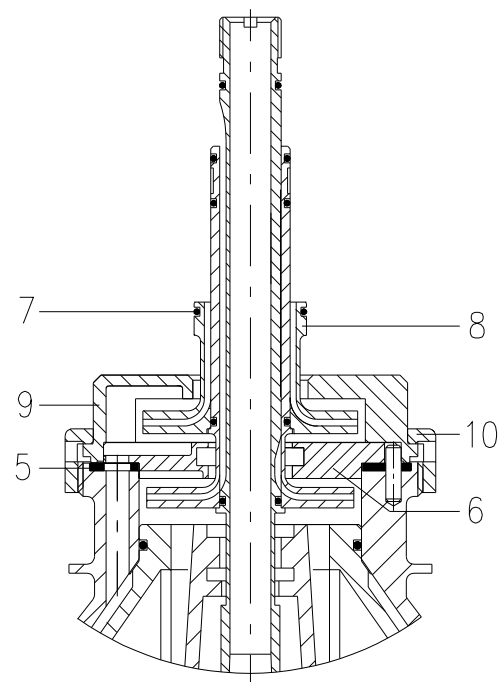

Figure 6.10

- 22) Place the cover on the frame, paying attention to not damage threads on feeding pipe, and fix it down tightly by suitable blockings (fig. 6.11). Proceed as follows:
 - Place down the cover. It can be positioned in every angular position.
 - Swing the blocking unit (1 to 4), until it assumes a vertical position.
 - Lay the clamp (3) to the cover (11) and fix it down by screwing the cap nut (1).

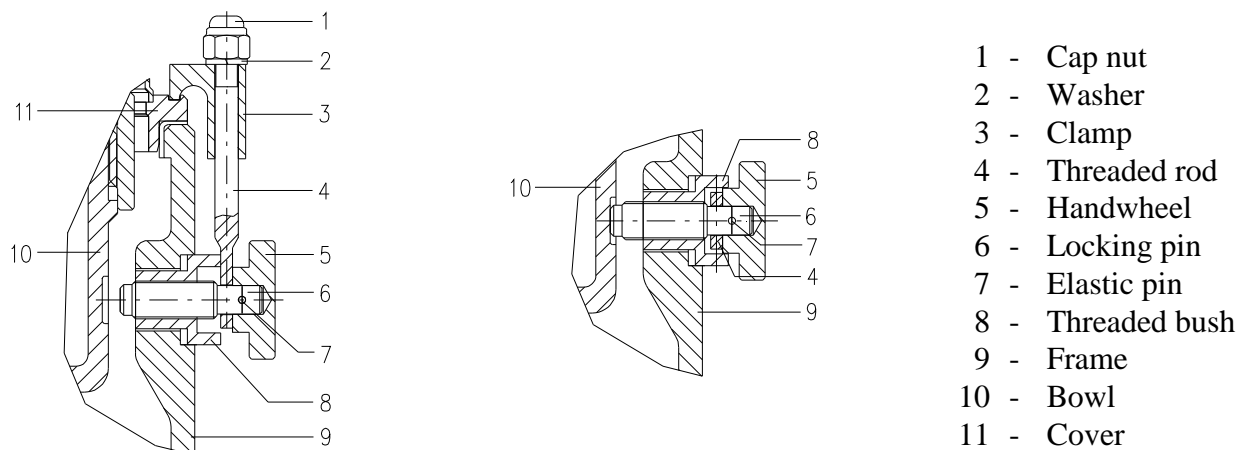

Figure 6.11

6.2. Inlet-outlet flow unit assembly

Before assembling, check all gaskets and grooves: they must be in good conditions and accurately cleaned. The spanners necessary for assembly are reported in Tab. 09. Do not use other tools or use them with caution.

The feeding pipe and the two centripetal pumps must be assembled in sequence with the last parts of the bowl (see § 6.1), then fix the cover on cyclone and finally the remaining parts of inlet-outlet flow unit.

Proceed according with the following procedure (fig. 6.12):

- 1) Apply on the shutters (9) the OR gaskets (7).
- 2) Insert in the inlet-outlet body (14) the teflon gaskets (8).
- 3) Mount on the inlet-outlet body (13) the shutters (9).
- 4) Apply on the skim shutter (11) the OR gaskets (10) and then mount the piece in the inlet-outlet body (13).
- 5) Assemble spacers (12) on body (13).
- 6) Insert body on the feeding pipe (1), adapting it on skim pump (5) and on the correspondent seat on the cover.
- 7) Screw hardly the two screws (15) into the holes of the cover.
- 8) Insert washer (16) and screw nut (17) - left-handed thread - using the spanners (09.050.0). Insert spanner (09.070.0) into the split of the feeding pipe to avoid pipe rotation when fastening the nut.
- 9) Install manometer (19) with appropriate gasket (18).

ATTENTION

Block the shutter screwing the appropriate screw STCEIEPS M 4X 6 (20-fig.6.12).

Always check:

- spacers thickness and number is the prescribed one (see § 3.3 and 6.3).
- locking nut of feeding pipe (left hand thread), fixing screws of cover to frame (Tab 0.8) and of inlet-outlet flow unit to cover are hardly screwed.

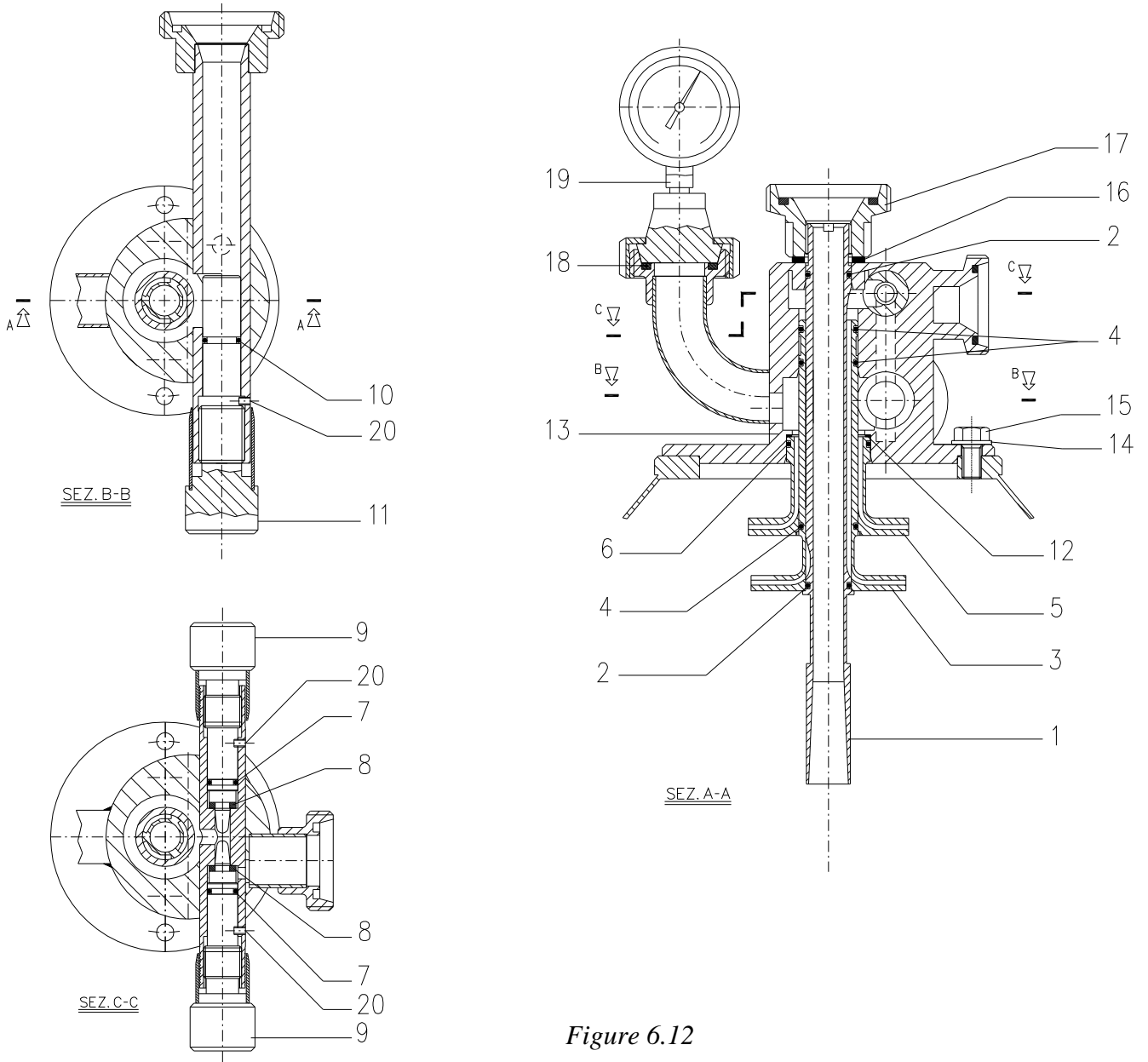

Figure 6.12

- | | |
|------------------------------|-------------------------------|
| 1 - Feeding pipe | 10 - OR gasket - skim shutter |
| 2 - OR gasket - feeding pipe | 11 - Skim shutter |
| 3 - Centripetal pump - cream | 12 - Spacer |
| 4 - OR gasket - cream pump | 13 - Flow unit body |
| 5 - Centripetal pump - skim | 14 - Washer |
| 6 - OR gasket - skim pump | 15 - Screw |
| 7 - OR gasket | 16 - Nylon washer |
| 8 - Teflon gasket | 17 - Feeding pipe nut |
| 9 - Cream shutter | 18 - OR gasket - manometer |
| | 19 - Manometer |
| | 20 - Screw STCEIEPS M 4X 6 |

6.3. Adjustment of pumps position

The correct position of pumps is shown by fig. 6.10; the pump is in the middle of the corresponding chambers of the bowl. This position is obtained by inserting a few spacers (12) - fig. 6.12 between the centripetal pump (5) and the inlet-outlet flow unit body (13). The number and thickness of spacers may vary only after the replacement of some parts of the vertical shaft unit (Tab. 06) and/or of the bowl (Tab. 04) and/or of the inlet-outlet flow unit (Tab. 05). In this case it is advisable to vary corresponding number and thickness of spacers indicated on technical card § 3.3. The total thickness of spacers is determined by the following relation:

Total thickness of spacers = 7,5 - A

To find "A" push down the centripetal pump (3) to the bottom of the corresponding bowl chamber. The distance (measured in mm) between the cover upper edge and the pump give the value of "A" (fig. 6.13). Extract all existing spacers before doing this measure.

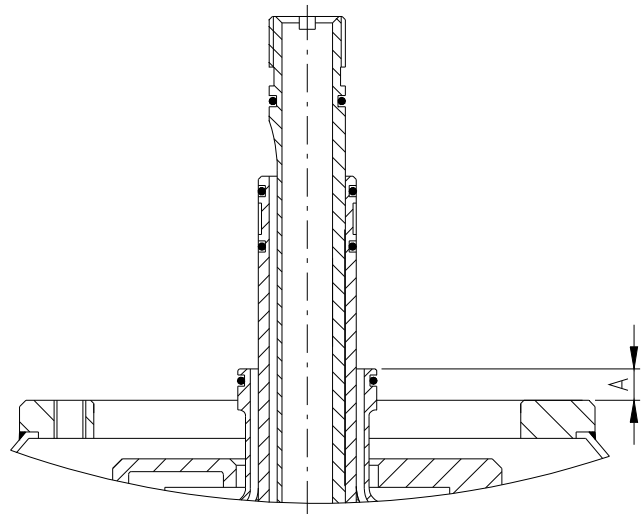

Figure 6.13

6.4. Inlet-outlet flow unit disassembly

ATTENTION

Generic danger

Only with bowl completely standstill is possible to start disassembly.

ATTENTION

Generic danger

Before disassembly, always perform machine chemical cleaning, that finish with cold water rinsing for about 5 minutes.

In case it is not possible to perform the cleaning, cool the bowl passing through it cold water or other cooling fluid, before starting disassembly.

ATTENTION

When disassembling is suggested to put in a suitable area the dismantled components to make easier finding them out and to verify the completeness of the assembly at the end of it.

Proceed in inverse order than assembly (see Fig. 6.12).

- 1) Disconnect feeding pipe and outlet pipes.
- 2) Insert spanner (09.070.0 - Tab. 09) into the split of the feeding pipe and unscrew nut (17) - left-handed thread - using spanner (09.050.0).
- 3) Extract the nylon washer (16).
- 4) Unscrew the two screws (15), that fix the inlet-outlet flow unit to the cover.
- 5) Lift up the inlet-outlet body (13).

6.5. Bowl disassembly

- 1) Disassemble the **cover** proceeding as follows:
 - loosen the cap nuts (1 - fig. 6.11) of the blocking elements;
 - remove the clamp (3 - fig. 6.11). This allow the threaded rod to rotate and assume the horizontal position;
 - take out the cover (11 - fig. 6.11).
- 2) Screw the **locking pins** to prevent bowl rotation (fig. 6.11). To do this:
 - rotate the bowl body until the "0" mark is aligned with one of the two locking pins;
 - screw the first locking pin (6), by turning clockwise the handwheel (5). It fit the circular groove on the bowl body. Do not force the locking;
 - screw the second locking pin without fasten it too much.
 - simultaneously fasten the two handwheel.
- 3) By the spanner (09.060.0) and the mallet (09.030.0), unscrew the **small lock ring** (9 - fig. 6.9).
- 4) Remove the **finned cover**.
- 5) Take out the **skim pump**.
- 6) Remove the **dividing disk** and the **drilled gasket of the dividing disk**.
- 7) Extract the **feeding pipe** and the **cream pump**.
- 8) By striking with mallet (09.030.0) the handle of the spanner (09.020.0) and then turning it by hand, unscrew and take out the **big lock ring** (10 - fig. 6.1).
- 9) By the spanner (09.010.0), extract the **bowl hood** (fig. 6.7). Proceed as follows:
 - open the two ends of the spanner wide apart;
 - insert the middle part of the spanner under the tooth placed at the end of the conical part of the bowl hood;
 - gripping by hands the two ends of the spanner lift the piece to a complete releasing.

- 10) If the **upper finned disk** (6 - fig. 6.1) has not got out with the bowl hood, take it out now by hands.
- 11) Extract the **disks**. Take care to not change the succession of the disks.
- 12) By the spanner (09.080.0) take out the **distributor** (fig. 6.4). Proceed as follows:
 - screw the tap of the spanner into the threaded hole of the piece;
 - lift the piece.
- 13) By the suitable spanner (09.040.0) and using the mallet, unscrew the **bowl body nut** (2 - fig. 6.1).
- 14) Unscrew the locking pins (6 - fig. 6.11), by turning them anticlockwise.
- 15) By the spanner (09.080.0), extract the **bowl body** (fig. 6.2). Proceed as follows
 - screw the spanner on the hub of the bowl body;
 - lift up the bowl body by hand or by hoist.

7. MACHINE START

7.1. Warnings

Before machine starting, be sure to have understood the contents of this Handbook. For explanations and deepenings contact the manufacturer.

The normal operation and maintenance personnel have to own the specific expertise required by this Handbook, as well as the psychophysics requisites necessary and sufficient to make an intervention on the machine.

ATTENTION
Generic danger

Only qualified and authorized personnel may perform regulations and interventions that are not assigned to the simple operator.

7.2. Safety systems description

ATTENTION
Generic danger

Never tamper safety devices. Before setting at work the machine check their correct positioning and always verify their efficiency.
In case of bad working inform the maintenance responsible.

7.2.1. Project devices

To reduce the risks, it has been realized an opening on the frame closed by a sight glass, which permits to check if bowl is rotating or not.

7.2.2. Shields

The following shields are presents:

- A series of steel shields are fixed with screws that totally prevent the access to the moving internal parts of the machine:
 - n°.1 bowl protection cover;
- Motor protection cover.

7.2.3. Warning bill-stickings

In accordance with EEC 89/392 directives and his amendments, the following notice bill-stickings has been predisposed (Tab. 03/B):

- On the motor connection box (if electric panel is not present):

	<p style="text-align: center;"><u>GENERIC ALERT</u> MOTOR TERMINAL BOARD IS PREDISPOSED TO BE CONNECTED TO A “400 V” LINE</p>
---	--

- On the bowl protection cover:

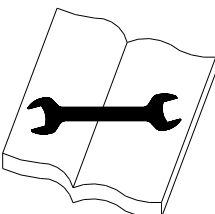
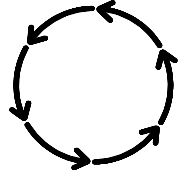
	<p style="text-align: center;"><u>SAFETY ALERT</u></p> <ul style="list-style-type: none"> • CONSULT TECHNICAL MANUAL FOR PROPER SERVICE PROCEDURE • WAIT UNTIL ALL ROTATING PARTS HAVE COMPLETELY STOPPED BEFORE REMOVING SAFETY SHIELDS (check gears motion state as indicated in Fig 2.1).
	 <p style="text-align: center;">STOP</p>

- Up the brake handwheel:

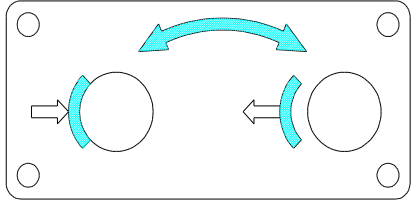
	<p style="text-align: center;"><u>TO BRAKE:</u> TURN THE HANDWHEEL ANTICLOCKWISE</p> <p style="text-align: center;"><u>TO DISACTIVATE THE BRAKE:</u> TURN THE HANDWHEEL CLOCKWISE</p>
---	---

It's absolutely necessary to recognize the meaning of the warning bill-stickings and maintain the message readable. In case of deterioration, the stickings must be immediately substituted avoiding the use of the machine until it's unprovided with them.

It's recommended to comply with the remarks referred on the stickings.

7.3. Regulation and control devices

To adjust and control the machine operation on product outlets are present the following devices:

- no. 2 shutters for cream and skim milk regulation;
- no. 1 shutter for standardization;
- no. 1 manometer;
- no. 1 constant pressure valve, to maintain constant the counter-pressure at the outlet of the skim milk. The regulation is performed by acting on pressure regulators (RPL, RPT - fig. 7.1) placed on the back side of electric panel;

Separator equipped with constant pressure valve

The supply is complete of the following pneumatic components (fig. 7.1):

- working pressure regulator (RPL)
- overflow pressure regulator (RPT)
- working pressure manometer (MNL)
- overflow pressure manometer (MNT)

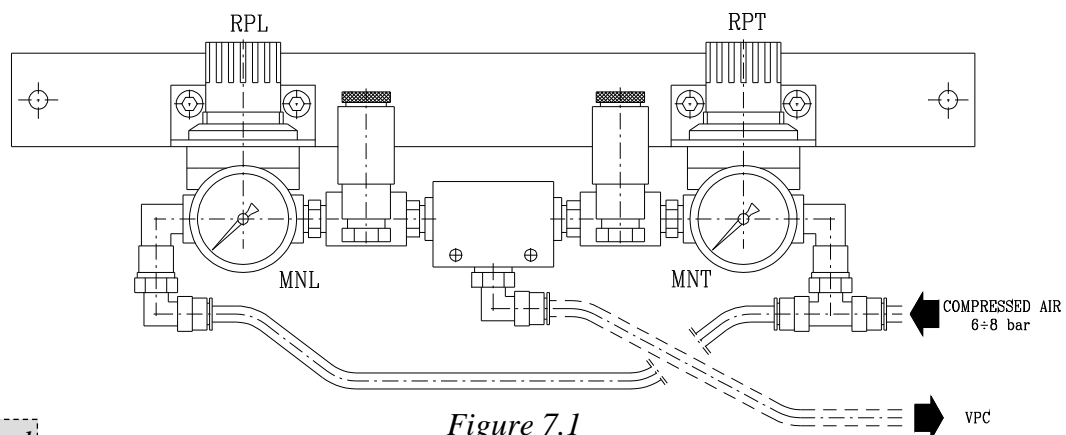

Figure 7.1

Optional

7.4. Stop of separator

To stop the separator proceed as follows:

- 1) Stop the separator feeding by closing the suitable valve.
- 2) Cut out motor of separator and let bowl stop by itself. Work on brake only if necessary.

ATTENTION **Generic danger**

The BRAKE must be used ONLY after the MOTOR has been electrically CUT.

7.5. Energy sources disconnection

ELECTRIC ENERGY

The general interrupter on the electric panel (door interlock) permits disconnection of the electric feeding. The interrupter can be lock to be sure of more security.

This interrupter can be used like an emergency stop.

7.6. Preliminary checks

- The bowl must be correctly assembled: the locking rings must be screwed right down (left-hand threaded) and the marks “O” of the corresponding parts must be aligned.
- All the fixed protections (cover, ports, etc.) must be in right position.
- Verify that inlet-outlet flow unit and cover are well fixed.
- Verify that the feeding pipe nut is well screwed (left-hand threaded), in order to obtain a good fixing of the centripetal pump.
- Check oil level (oil must be slightly above the mark on the sight glass).
- Brake must be released.
- Check that valves at the outlet of the product are closed.
- If separator doesn't work for a long time (more than 3 months), it is recommended to:
 - oily separator again following the instruction indicated at § 5.5.1;
 - start the machine without bowl for about 5 min.

ATTENTION
Generic danger

Before start always verify the efficiency of the security devices and of the stop command.

7.7. Starting up instructions

ATTENTION
Generic danger

The machine OPERATOR MUST BE PRESENT at the starting-up phase.

- Referring to the recommended wiring diagram (fig. 5.4), at start, push start motor button (P1) so:
 - the green lamp light on;
 - contactors KM1 and KM2 are engaged and motor protection is by-passed;
 - timer T1 begin counting.When the setting time is elapsed:
 - contactor KM2 is switched off;
 - thermal protection TM1 is activated.
- Check the regular start of separator and wait for reaching nominal speed (about 2 minutes). The tachometer indicates the rotation speed of the horizontal shaft connected to the motor (nominal speed is about 1.450 r.p.m.).
- Check vibration and noise of separator. If vibration and/or noise are anomalous, stop the separator for a carefully check.
- Feed separator with product. If necessary regulate the flowrate using micrometric valves of inlet-outlet unit.

ATTENTION
Generic danger

During starting-up the machine has not to rotate with empty bowl for a period up than 15 min.

8. MACHINE USE

8.1. Personnel tasks

Unmanned automatic machine, starting phase only.

Operator tasks:

- Normal operation control.
- Good operation testing (fluid level, capacity and temperature value, noisy, evident vibrations).
- Carry out cleaning cycle.
- Routine interventions on electric panel.
- Simple disassemblies.
- Lubricant oil change or topping up.

Mechanical technician tasks:

- Corrosion and wears testing.
- Repairs.
- Preventive maintenance with eventual cleaning and/or replacement of some parts.

Electrician tasks:

- Interventions on electric system.

8.2. Set-up and adjustments

Regulate the separator capacity within the nominal value shown on § 3.3. To achieve this, it is necessary to insert a regulatory valve or a neck washer on the separator feeding line.

It's important to avoid air mixing with liquid, so it's necessary to immerse the centripetal pump into the rotating liquid and to have a counterpressure in outlet pipes. This is obtained by acting on the regulating valves (A, B, C in figure 8.1).

As general behavior remember that, by acting on outlet valves, it's possible to adjust the cream flow rate, while the skim milk flow rate cannot be varied.

One of the most important parameters in milk separation is the fat content of the cream, directly related to the cream flow rate. A small cream flow rate gives a cream of higher density, with more fat, while a large cream flow rate gives a thinner cream with lower fat content.

Valve (A in figure 8.1) regulate the outlet pressure of skimmed milk (the manometer P, shows the counter pressure at the outlet of the skim centripetal pump), while valve (B) permit to adjust the flow rate and pressure of the cream. To regulate the fat content of the milk (standardization), a third valve (C) has been applied in the internal channel between the cream outlet and the milk outlet. By opening this valve, some of the separated cream can be added to the skimmed milk before it leaves the separator.

8.2.1. Warnings

- Always act slowly on valves and wait after each setting until the separation stabilizes before doing another change.
- When the desired regulation has been achieved, mark the position of each shutter.
- To avoid butter oil or foam formation it's necessary to work with higher pressures both in skim milk and in cream. Do not increase too much pressure values as this cause a reduction in regulation sensibility.

Separator equipped with constant pressure valve

- Rotate the pressure regulator of the bowl overflow RPT (fig. 7.1) until on MNT (fig. 7.1) could be read a pressure of about 6 bar.
- The regulation of counter-pressure at skim outlet could be performed acting both on shutter A and on regulator RPL. For the best regulation:
 - act on regulator RPL in such a way that the pressure fall to zero;
 - rotate shutter A until a pressure of $2,5 \div 3$ bar could be read;
 - perform subsequent adjustings acting only on regulator RPL.
- For a correct understanding of the regulation procedure reported below, at the words "shutter A" should be substituted "regulator RPL".

8.2.2. First setting

- 1) Feed the separator with water.
- 2) Completely close shutter C.
- 3) Partially open shutter B.
- 4) Gradually close shutter A until some water flow out of cream outlet.
- 5) The pressure read from the manometer is the minimum working pressure (MWP).

- A - Skim milk shutter
B - Cream shutter
C - Remixing shutter
P - Manometer

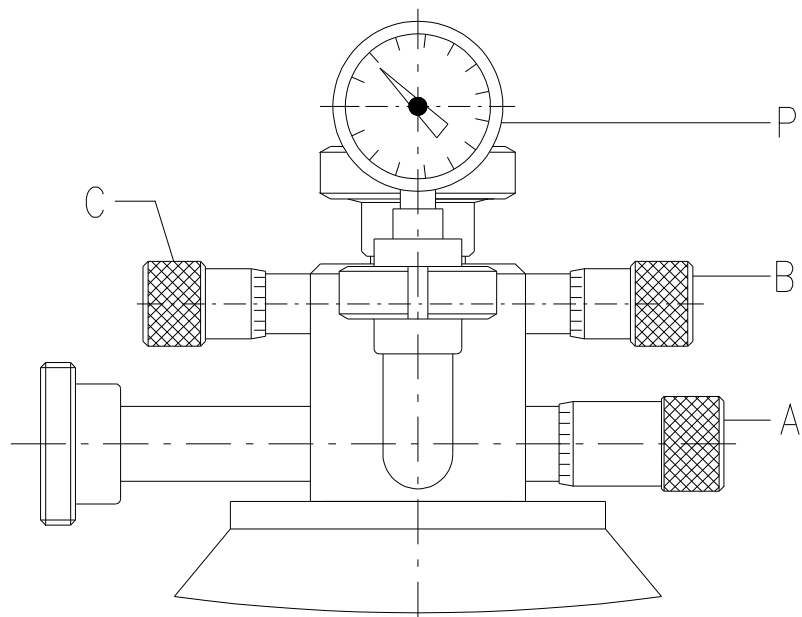

Figure 8.1

8.2.3. Skimming milk or whey

- 1) Completely close shutter C
- 2) Partially open shutter B
- 3) Regulate shutter A in order to bring the pressure on the manometer to approximately $0,1 \div 0,2$ bar up the MWP.
- 4) Still close the shutter A to obtain a cream more liquid than desired.
- 5) Close shutter B to increase cream density.
- 6) If some foam is present in milk or cream, it's necessary to close shutters A and B.

8.2.4. Partial milk skimming (standardization)

Bear in mind that shutter C regulates the quantity of cream that is re-blended with the skimmed milk.

- 1) Partially open shutters B and C
- 2) Regulate shutter A in order to bring the pressure on the manometer to approx. 0,5 bar up the MWP.
- 3) Regulate shutter B to vary the cream flow rate. The opening of shutter B increases the quantity of produced cream, but with a lower density (closing has the opposite effect).
- 4) The opening of shutter C causes an increase in the fat content of the skimmed milk and therefore also a decrease in the quantity of cream produced.

Cream too liquid

- Close shutters B and C. If this is not sufficient open a little bit shutter A.

Cream too thick

- Increase skim milk pressure by closing shutter A and open a little bit shutter B.

8.2.5. Milk cleaning

For a good cleaning most of liquid must flow through skim milk outlet.

- 1) Completely close shutter B.
- 2) Partially open shutter C.
- 3) Act on shutter A increasing the pressure until the bowl start overflow and a product leakage can be seen from draining pipe of solids.
- 4) Reduce the pressure until the liquid stop flowing off from the draining pipe.
- 5) The pressure read on the manometer (19 - fig. 6.12) is the maximum working pressure - approx. $4,5 \div 5$ bar.
- 6) Regulate shutter A in order to bring the pressure on the manometer to approx. 0,5 bar down the maximum working pressure.
- 7) In this condition the best working of the machine is guaranteed.

8.3. Ordinary maintenance

To guarantee the machine functionality and long-life, the operator must perform cleaning and ordinary maintenance.

Ordinary maintenance

Before every shift

Oil level check

Brake disconnection check

Operating machine

General operation check

Control of capacity value and temperature

At the end of every shift

Machine chemical cleaning to remove working residuals.

8.4. Separator chemical cleaning

At the end of every working the separator must be chemically cleaned. This allow to maintain at a high level the efficiency of the separator and to assure the hygiene of the parts in contact with the product.

<p>ATTENTION</p>

<p>Generic danger</p>

<p>Cleaning solutions must NOT contain CHLORINE</p>

The bowl unit must be cleaned, if necessary, using **alkaline deteratives** (they must not contain acid components).

Rinse all the cleaned parts with abundant water.

Clean with a sponge the top chamber of the frame, where is placed the bowl, and the drain hole of it.

Do not use jets of water.

9. GEAR

Handle with care every components of the transmission gear in the disassembly/assembly phase. Avoid impacts and injuries to components; utilize suitable equipment only.

9.1. Disassembly of vertical shaft (Tab 06)

ATTENTION

When disassembling is suggested to put in a suitable area the dismantled components to make easier finding them out and to verify the completeness of the assembly at the end of it.

To dismantle vertical shaft, first of all displace helical wheel (parts from 07.190.0 to 07.230.0) to the right side making it run along the horizontal shaft (Tab. 07).

Then proceed as follows:

- 1) Remove from the shaft the labyrinth (06.300.0) with its (OR 06.290.0).
- 2) Remove the screws (06.280.0) and the cage cover (06.260.0).
- 3) Remove the elastic support assembly: collar cage (06.240.0) with all its parts.
- 4) Remove the rings (06.180.0) and (06.170.0).
- 5) Extract the vertical shaft (06.140.0) together with its bearings.
- 6) Remove the spheric support (06.060.0) by screwing a screw M10 into its threaded hole.
- 7) To extract the bush (06.020.0), unscrew the three screws (06.030.0) and screw two of them in the other threaded holes on the flange of the bush.

9.2. Assembly of vertical shaft (Tab 06)

Before assembly vertical shaft accurately clean and control all parts, paying particular attention to gasket and ball bearings.

- 1) Insert the lower spring (06.050.0) and the spheric support (06.060.0) in the bush (06.020.0).
- 2) Fix the bush with its OR (06.010.0) to the frame.
- 3) Preassemble the parts from (06.070.0 to 06.160.0) on the vertical shaft (06.140.0).
The two thrust ball bearings (06.080.0) must be set as shown in figure 9.1.

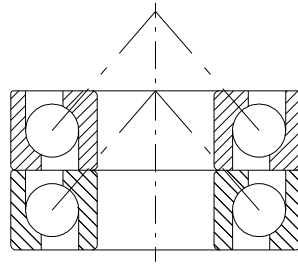

Figure 9.1

- 4) Insert the vertical shaft into the frame: guide the lower ball bearing (06.100.0) into the bush (06.020.0).
- 5) Set the spacer rings (06.170.0) and (06.180.0) on the vertical shaft.
- 6) Set the elastic support assembly (parts from 06.190.0 to 06.240.0).
- 7) Mount the cage cover (parts from 06.250.0 to 06.280.0).
- 8) Fit the labyrinth (06.300.0) with its OR (06.290.0) on the vertical shaft and push it downwards.

9.3. Disassembly of horizontal shaft (Tab 07)

ATTENTION

When disassembling is suggested to put in a suitable area the dismantled components to make easier finding them out and to verify the completeness of the assembly at the end of it.

To completely dismantle horizontal shaft, first of all, stake down clamping flange of gear housing, brake unit and motor cover by operating on suitable screws (Tab. 08). Then proceed as follows:

- 1) Remove the motor with shoe-holder and clutch shoes (parts from 07.010.0 to 07.060.0) after having unscrewed the screws (07.020.0). Do not dismantle the circlips of the shoe-holder to avoid unbalances. Dismantle the motor flange (07.080.0) only if the motor must be replaced.
- 2) Unscrew the cover (07.350.0, the tachometer (07.340.0) and the screws (07.310.0).
- 3) Extract the tachometer side support (07.270.0) with the bearing (07.250.0) and the OR gaskets (07.260.0). The operation is effected by screwing the two screws (07.310.0) in the threaded holes of the flange of the support.
- 4) Loosen the screws (07.230.0) of helical wheel (07.200.0) and move the wheel on the right side.
- 5) Remove screws (07.110.0) (through the holes of the clutch pulley) extract horizontal shaft (07.090.0) by the frame together clutch side support (parts from 07.130.0 to 07.180.0) extracting at the same time helical wheel (07.200.0) to horizontal shaft. The operation is effected by screwing two screws (07.110.0) into the two threaded holes of the flange (07.140.0). Pay attention to avoid shocks on gears. Extract helical wheel by the frame.

9.4. Assembly of horizontal shaft (Tab 07)

Before assembly clean and check all parts carefully, with particular attention to gasket and ball bearings.

When assembling the horizontal shaft, place the two supports (clutch side and tachometer side) so that the groove on the ball bearing housing of the support 07.140.0 and the oblique hole on the ball bearing housing of the support 07.270.0 are at the bottom side.

- 1) Preassemble the clutch side support (parts from 07.130.0 to 07.180.0) and then insert therein the horizontal shaft (07.090.0) fastening it with the circlip (07.180.0).
- 2) Insert the assembly thus obtained into the frame and fix the support (07.140.0) with the screws (07.110.0).
- 3) Mount the helical gear wheel with flanges and screws (parts 07.190.0 to 07.230.0) onto the horizontal shaft and fix the wheel by screwing the screws (07.230.0).
- 4) Insert the tachometer side support (parts 07.240.0 - 07.270.0) in the frame and fix it with the screws (07.310.0). Mount then the tachometer (07.340.0) and the cover (07.350.0).
- 5) Preassemble the clutch shoe-holders and shoes (parts 07.040.0 to 07.060.0) on the motor shaft (07.010.0) and then fasten all to the frame with the screws (07.020.0). Clutch shoe must be set as indicate in Fig. 9.2 (with reference to motor direction of rotation) and insert on shoe holder in symmetrical position. Before carrying out this step of the assembly, carefully clean the clutch pulley and shoes with abrasive cloth.
- 6) Remount the brake assembly and the motor casing, fastening them with its screws (Tab. 08).
- 7) Fill gear chamber with recommended oil (see § 5.5.1).

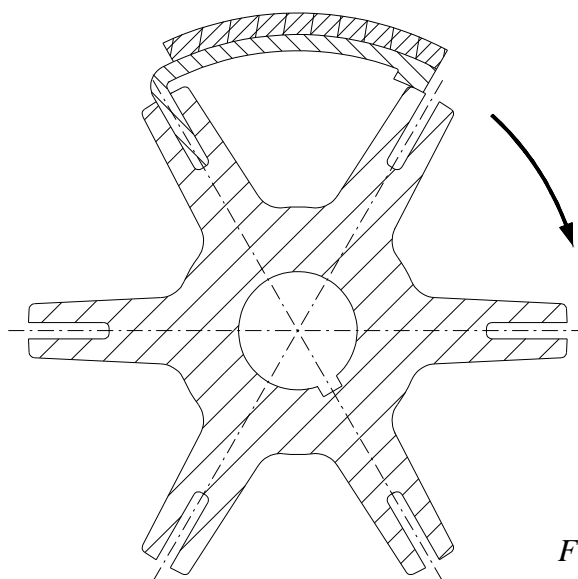

Figure 9.2

10. MAINTENANCE

10.1. Remarks

ATTENTION
Generic danger

All the preventive and extraordinary maintenance operations must be performed with machine not operating and with electric, hydraulic and pneumatic feeding disconnected.

ATTENTION
Danger of electrocution

Before performing interventions be sure the tension is disconnected.
It is not sufficient open the general interrupter to completely disconnect the tension on the control panel because current is still present in the terminals of the block-door interrupter.
Every electric intervention must be performed by electrician (qualified and competent person).

Extraordinary maintenance

Oil change and accurately cleaning of gear chamber.

Bowl disassembly and accurately cleaning of each part.

Lubrication of bowl big lock ring and guides and sliding surfaces.

Lubrication of motor ball bearings according to manufacturer instructions.

Check of bowl gaskets.

Check of springs and buffers (eventual replacement).

Check of brake lining height.

Check the presence of water in lubrication oil.

Control of clutch shoes wear.

Remove the gear sight glass and check helical toothing of crown gear.

Check erosion and corrosion of threads of lock rings.

Replace ball bearings.

Repairs after accidental broken.

10.2. Corrective and preventive maintenance

Periodical maintenance and correct use are indispensable elements to warrant functionality, safe operation and long life of machine. Extraordinary maintenance interventions, at prescribed intervals, must be performed by mechanical technician who must operate in accordance with safety prescriptions reported in this Handbook. Check the effective working time of the machine, reading the value reported in the hour counter placed inside the electric panel.

Preventive maintenance Plan

Operating hours						Maintenance	Frequency				
300	750	1500	2500	5000	10000		every day	1/4 year	1/2 year	1 year	2 years
●						First oil change after initial start-up and thorough cleaning of gear chamber.					
						Check oil level.	●				
		●				Oil change and thorough cleaning of gear chamber.					
whenever disassembling						Grease bowl big lock ring and guide and sliding surfaces.	whenever disassembling				
			●			Remove bowl and clean interior of frame.			●		
	depends on product					Dismantle the bowl and clean thoroughly bores and chambers of the hydraulic system.		depends on product			
		●				Check bowl gaskets.					
		●				Check starting time and rated speed.					
		●				Check buffer springs and buffers of vertical shaft support. Check brake shoes.					
						Check the presence of water in lubrication oil.		●			
					●	Check gearing of helical wheel gear.					
						Bowl inspection. Check erosion and corrosion on threads of lock rings.				●	
					●	Replace ball bearings on vertical shaft.					
					●	Replace ball bearings on horizontal shaft.					
					●	Replace ball bearings of motor.					
					●	Replace buffer springs of vertical shaft support.					

10.3. Troubleshooting

The following table shows the main problems that may happen during operation.

n°	TROUBLE	CAUSE	REMEDY
1	Revolving speed of bowl inferior to the rated one or starting time being too long (more than 4-5 min).	Wrong electrical connection.	Check voltage of mains and make electric connection again.
		Brake applied.	Release brakes by screwing hand-wheel.
		Motor operating in star-mode.	Check the electrical equipment.
		Clutch shoes oily.	Clean shoes and clutch pulley with emery cloth.
		Clutch shoes worn.	Replace the shoes.
		Some dirty slow down the bowl.	Disassembly cover and bowl and accurately clean them.
2	Tachometer reads "O" while bowl is running.	Tachometer is not connected to the horizontal shaft.	Restore the connection correctly (drive pin, tachometer spring).
		Faulty tachometer.	Replace tachometer.
3	Standstill bowl while tachometer reads rated speed.	Helical gear wheel unclamped on horizontal shaft.	Tighten locking screws of helical gear wheel.
4	Bowl speed slows down during working.	Clutch shoes oily.	Clean shoes and clutch pulley with emery cloth.
		Clutch shoes worn.	Replace the shoes.
		Voltage drop.	Check voltage.
		Motor slows down during working.	Check motor.
5	Starting time too short (starting current too high).	Rust connect shoes and clutch pulley.	Clean shoes and clutch pulley with emery cloth.
		Wrong number of shoes.	Check number of shoes: they can't be more than three.

n°	TROUBLE	CAUSE	REMEDY
6	Anomalous vibration and excess of noise during working.	Bowl out of balance due to:	
		- incorrect assembly or with parts from other bowls.	Assemble bowl correctly.
		- disks column has not adequate compression.	Add some disks (§ 6.1).
		- bowl parts damaged during disassembly or assembly.	Bowl must be inspected by one of our technicians.
		- bad bowl desludging (vibration is higher with empty bowl).	Carefully clean the bowl and increase discharge time (T2) or reduce time between two following discharges (T1).
		- clutch shoes not disposed correctly.	Check shoes are simmetrically disposed.
		- big lock ring badly tightened.	Disassemble and tighten lock ring.
		Inefficient support of vertical shaft owing to:	
		- broken or fatigued springs	Replace whole set of springs.
		- buffers seized.	Replace all buffers.
		Worn-out ball bearings	Replace all ball bearings and use the prescribed ones.
		Gears are in bad conditions owing to normal wear or:	Replace worn out part as well as helical wheel and pinion; carefully clean gear housing and change oil using the prescribed one. Eventually change oil more frequently.
		- lack of oil or oil is too fluid (gears become bluish)	
		- water in oil, (frame drain obstructed cleaning of inner upper surface of frame by water jet).	
	- sludge in gear housing.		
	- delayed oil change.		
↓			

n°	TROUBLE	CAUSE	REMEDY
↑		- non contemporary replacement of helical wheel and pinion.	
7	Insufficient product separation	Capacity too high.	Reduce the capacity.
Incorrect regulation.		Follow instructions reported in chapter 8.1.	
Solids chamber filled		Stop the separator, disassemble the bowl and clean it.	
Disks column obstructed		Disassemble and clean: attention to the cleaning cycle	
Non suitable product temperature		Preheat product at the process temperature.	
Shutter C (fig. 8.1) is not completely closed.		Close shutter C.	
It is worn one of the following gaskets (fig. 6.1): - upper finned disk gasket (7), - gasket of dividing disk (11).		Replace the worn gasket.	
8	Leakage of milk or whey from the tangential pipe of the cover and/or from the frame.	Excessive pressure of product at the outlet.	Reduce the pressure unscrewing shutter A (fig. 8.1).
Excessively high capacity.		Reduce the capacity.	
It is worn one of the following gaskets: - upper finned disk gasket (7) fig. 6.1. - gasket of dividing disk (11) fig. 6.1. - skim centripetal pump gasket (6) fig. 6.12.		Replace the worn gasket.	
9	Leakage of cream from the tangential pipe of the cover and/or from the frame.	Excessive pressure of product at the outlet.	Reduce the pressure unscrewing shutter B (fig. 8.1).

n°	TROUBLE	CAUSE	REMEDY
10	Leakage of liquid from the frame.	The bowl hood gasket (8) - fig. 6.1 - is damaged or not correctly positioned.	Replace or correctly apply the gasket.
11	Foam in skim milk or in cream at the outlet.	Insufficient pressure.	Screw the shutters A or B (fig. 8.1) on separator outlet.
		Air infiltration in the product on the separator feeding line.	Check that every pipe union has its gasket, is closed and correctly expanded. Check that pump suck under water head. Pump must not suck air from its mechanical seal.
12	Foam in clean milk (milk cleaning)	Insufficient pressure.	Screw the shutters A (fig. 8.1) on separator outlet.
		Air infiltration in the product on the separator feeding line.	See remedy 11

11. DESACTIVATION/RESALE

11.1. Disassembly/Scrapping

The user, in accordance with EEC directives or in accordance with laws in force on own nation, is responsible about dismantling and elimination of every part of the machine. Before unbilding the machine, the user must communicate to the manufacturer all the data reported on the identification plate.

11.2. Components and materials elimination

In case of scrapping, the user, in accordance with local laws in force, must pay particular attention about elimination of materials which cause problems to the environment, as:

- Insulated cables,
- Rubber gaskets.

Toxics or corrosives substances are not present.

11.3. Resale

In case of resale as “used machine” the client/user must communicate all installation indications to the buyer, transferring him the responsibility concerning the above mentioned information.

12. SPARE PARTS

How to order spare parts

Machine is marked with a manufacturing number and a model that are evident on the identification plate.

IMPORTANT

To have a fast delivery of spare parts it is necessary that the following data are ever indicated:

- Model of the machine
- Manufacturing number
- Component reference, code and description
- Quantity of parts required

The information about the spare parts are presents in the Tables of chapter 13.

In a different way, spare parts could be requested using the forms found at the end of chapter 13, where spare parts, which substitution is more probable and frequent, are reported (gaskets, clutch shoes, etc.). In this forms it's sufficient to indicate:

- The model of the centrifugal separator where the parts must be installed;
- The manufacturing n° of the separator;
- The selected spare parts (filling with a X the suitable box);
- The requested quantity.

13. DRAWINGS AND DIAGRAMS

Sections and Diagrams

Tab.01	Vertical section
Tab.02	Horizontal section
Tab.03	Overall dimensions and installation plan

Spare parts Tables

Tab.04	Bowl
Tab.05	Inlet-Outlet flow unit
Tab.06	Vertical shaft
Tab.07/A	Horizontal shaft
Tab.07/B	Motor
Tab.08	Frame
Tab.09	Special spanners
Tab.22	Identification plates and alert stickers

VERTICAL SECTION - TAB. 01

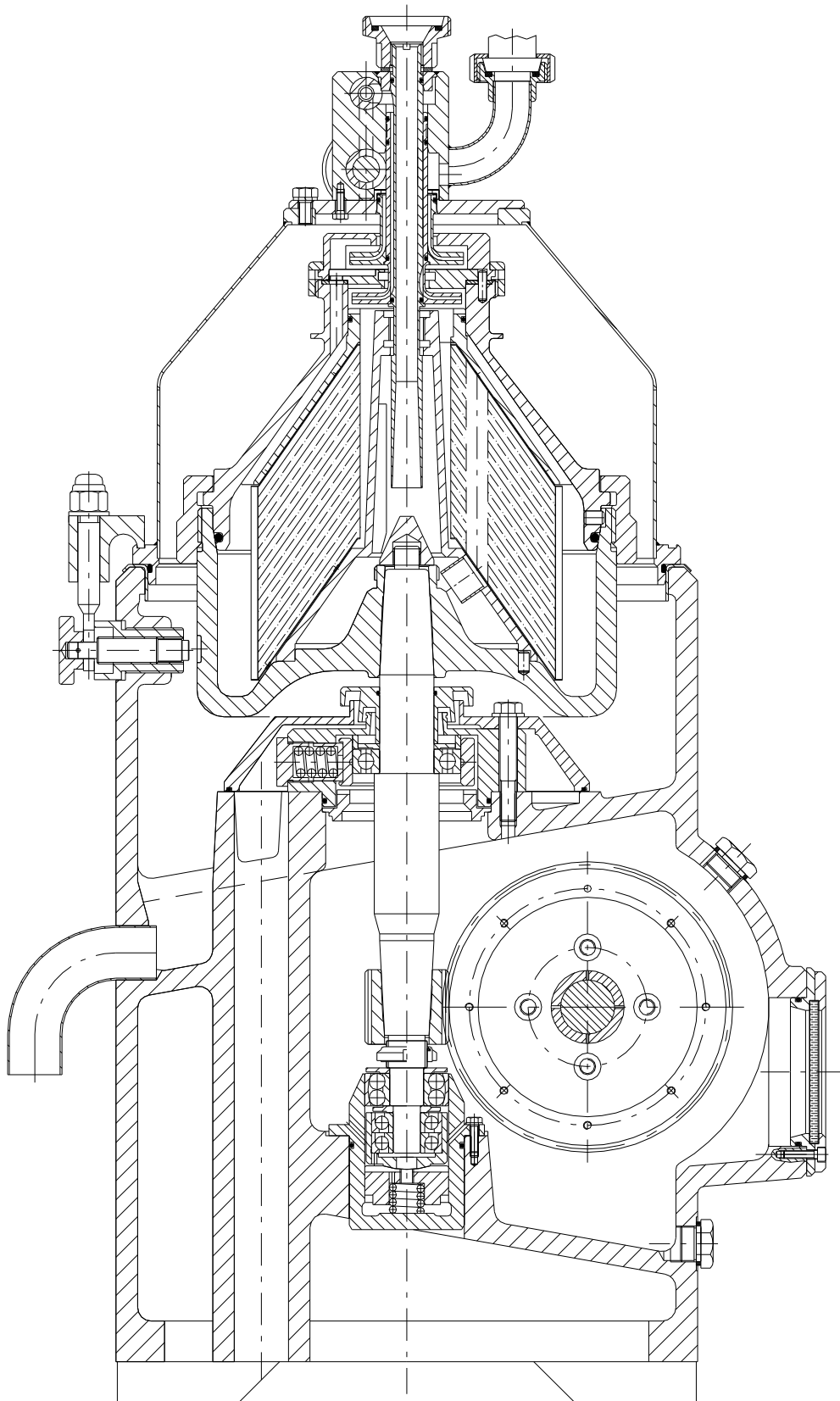

HORIZONTAL SECTION - TAB. 02

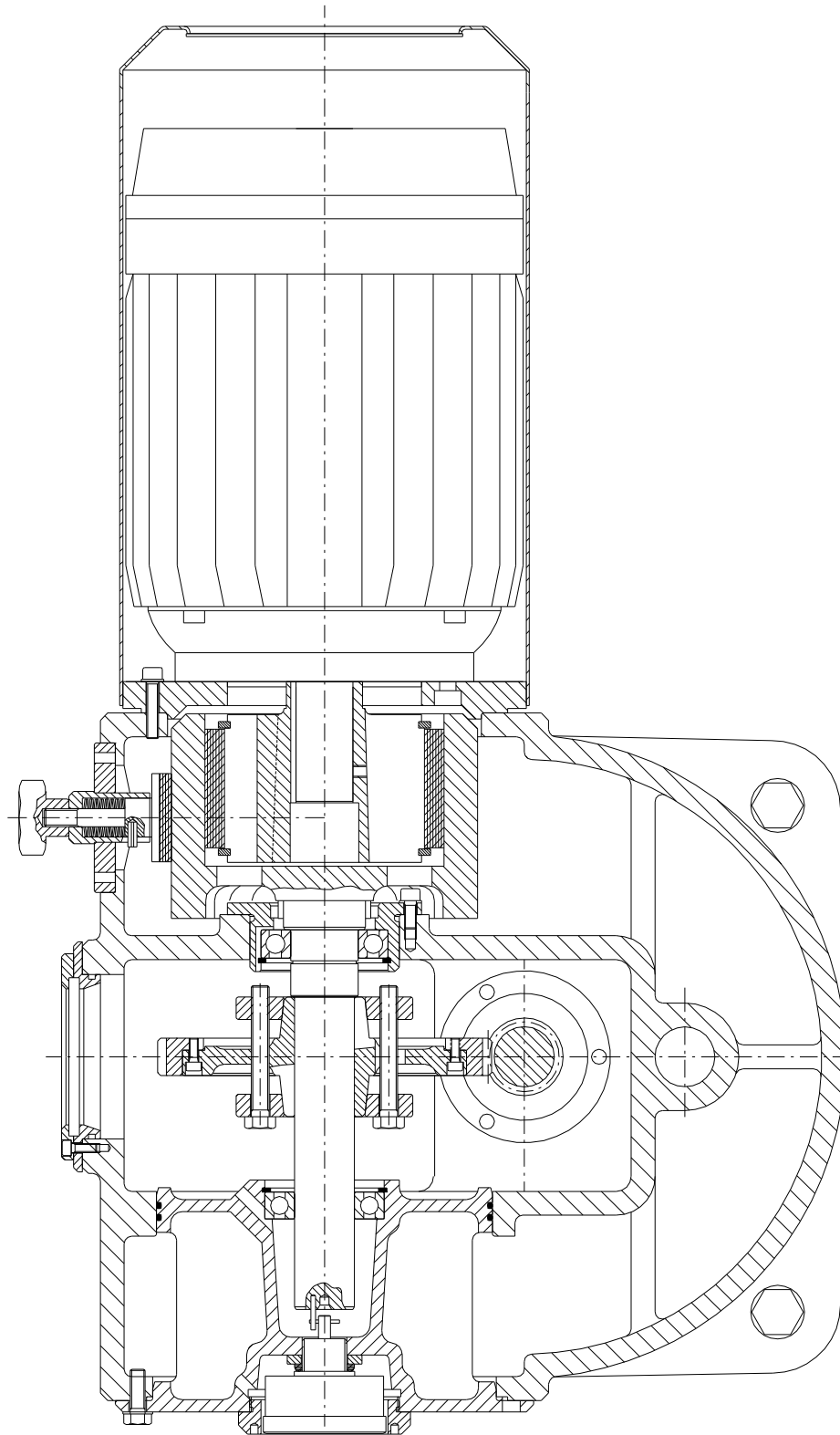

OVERALL DIMENSIONS AND INSTALLATION PLAN
TAB. 03

- A Product inlet DN40 DIN11851
- B Skim outlet DN40 DIN11851
- C Cream outlet DN25 DIN 11851

Shields and removable parts for maintenance operations

- 1 Cover
- 2 Oil supply plug
- 3 Oil drain plug
- 4 Flange - tachometer side support
- 5 Carter - motor

Components and equipments

- 10 Sight glass - check standstill machine and oil level
- 11 Brake handwheel
- 12 Cover clamp
- 13 Bowl locking pins
- 14 Pipes for motor cables
- 15 Drain
- 16 Foundation plate
- 17 Manometer
- 18 Micrometric valve - skim
- 19 Micrometric valve - cream
- 20 Micrometric valve - standardization

TAB. 03

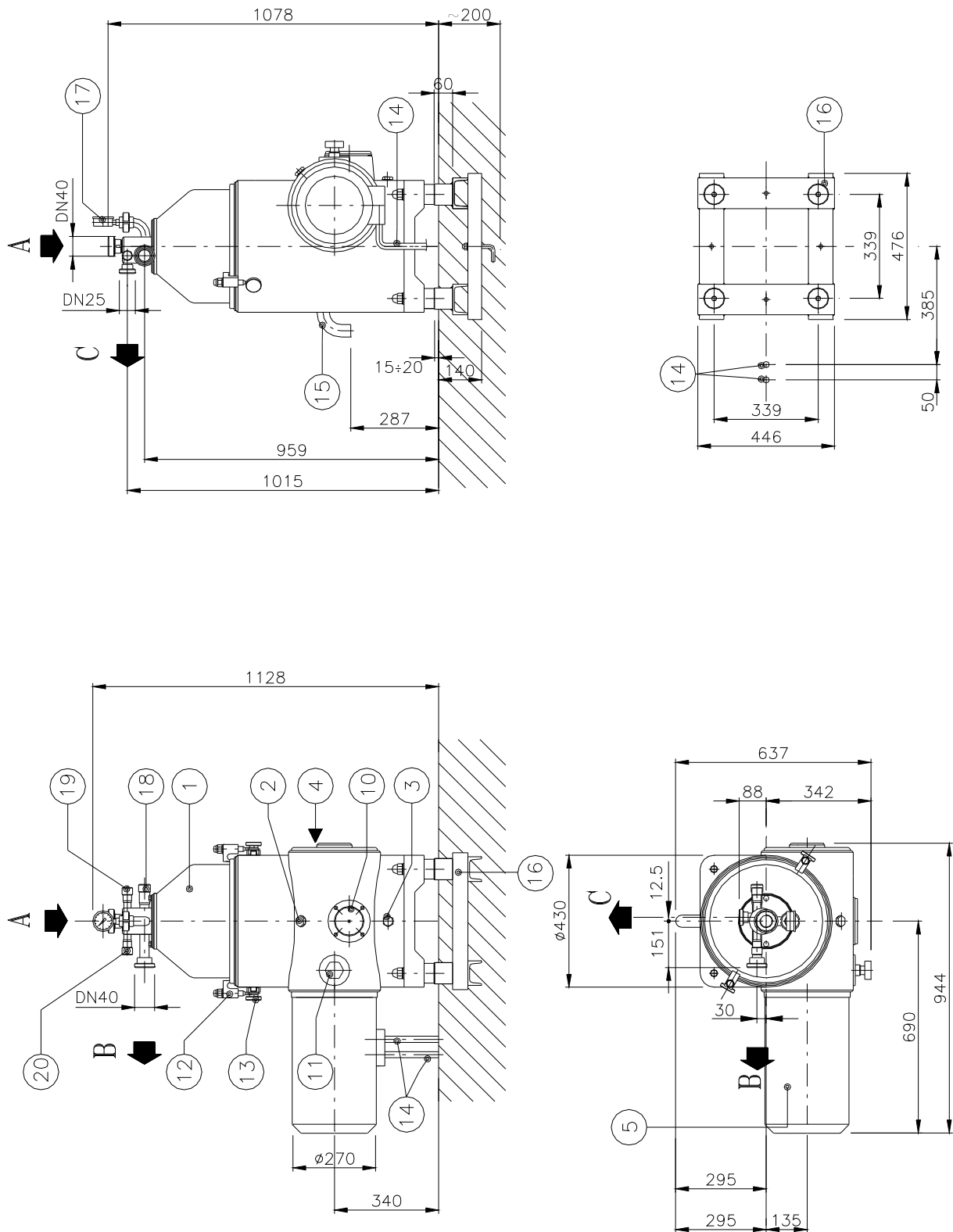

BOWL - TAB. 04

<u>Reference</u>	<u>Code</u>	<u>Quantity</u>	<u>Description</u>
04.010.0	200276100	1	Bowl body
04.020.0	400095200	1	Bowl body nut
04.030.0	200303200	1	Distributor
04.040.0	300105100	1	Bottom disk
04.050.0	300104500	~	Intermediate disk
04.060.0	300099100	1	Finned disk
04.070.0 *	528020423	1	OR gasket - finned disk
04.080.0 *	528020839	1	OR gasket - bowl hood
04.090.0	200274600	1	Bowl hood
04.100.0	300025500	1	Big lock ring
04.110.0 *	400152300	1	Gasket - dividing disk
04.120.0	300096900	1	Dividing disk
04.130.0	300065700	1	Finned cover
04.140.0	400027000	1	Small lock ring
04.520.0	832000016	1	Set of bowl gaskets (3 pieces,*)

TAB. 04

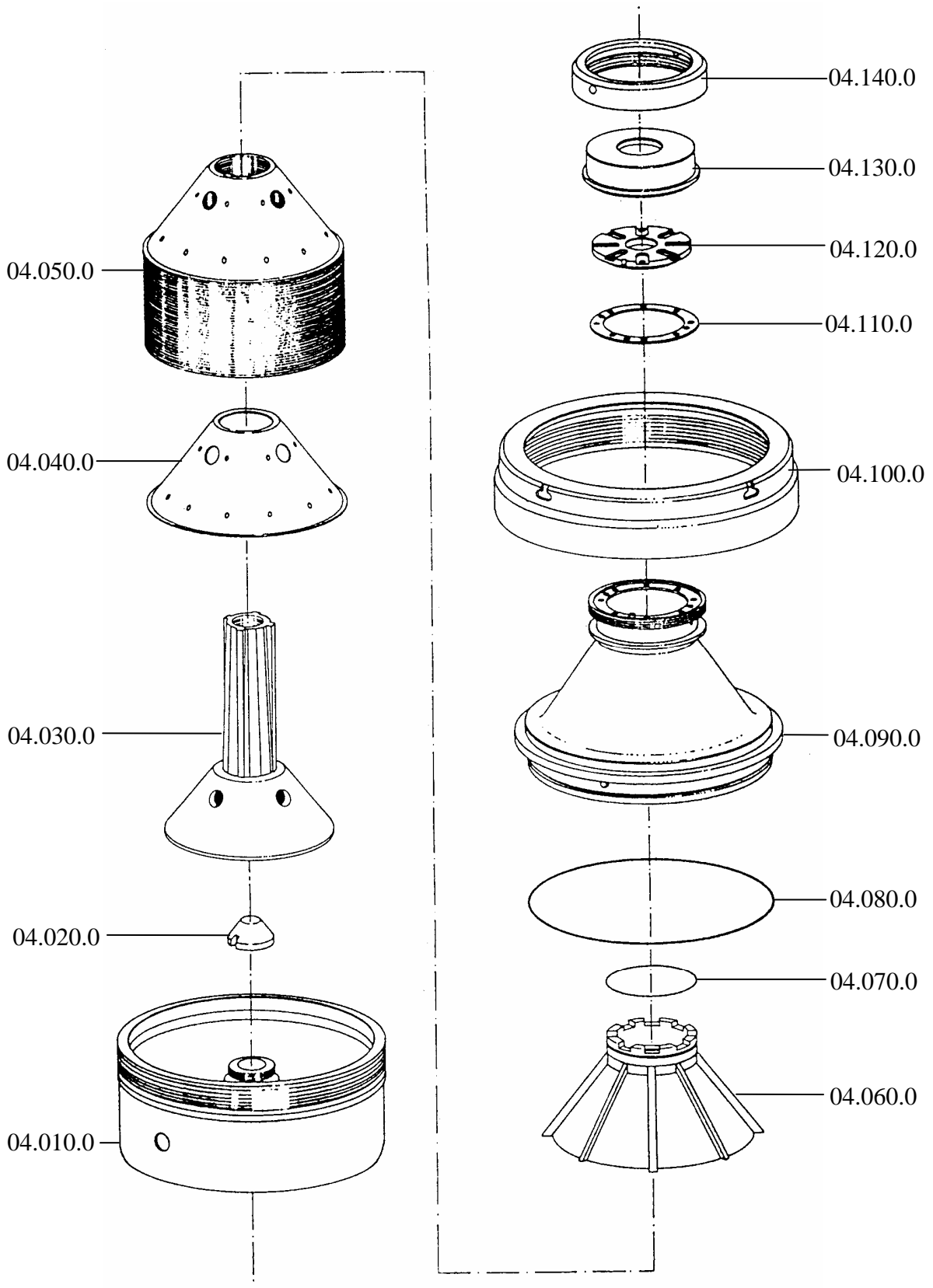

INLET-OUTLET FLOW UNIT - TAB. 05

<u>Reference</u>	<u>Code</u>	<u>Quantity</u>	<u>Description</u>
05.010.0	300251700	1	Feeding pipe
05.020.0 *	528020149	2	OR gasket - feeding pipe
05.030.0	400196700	1	Cream pump
05.040.0 *	528020170	3	OR gasket - cream pump
05.050.0	400302900	1	Skim pump
05.060.0 *	528020194	1	OR gasket - skim pump
05.070.0 *	528020119	2	OR gasket - shutter
05.080.0 *	400211600	2	Teflon gasket - shutter
05.090.0	400179300	2	Shutter (cream and standardization)
05.100.0 *	528020131	1	OR gasket - shutter
05.110.0	400179400	1	Shutter (skim)
05.120.0 **	40002320X	0÷4	Spacers
05.130.0	200079400	1	Inlet-outlet body
05.140.0	529056010	2	Washer Ø10
05.150.0	529006148	2	Screw M10x20
05.160.0 *	400212000	1	Nylon washer
05.170.0	400200000	1	Nut - feeding pipe
05.180.0 *	528151020	2	Gasket DN25 DIN11851
05.185.0 *	528151030	2	Gasket DN40 DIN11851
05.190.0	520060210	1	Manometer
05.510.0	832000018	1	Set of gaskets for fittings DIN11851 (16 pieces)
05.520.0	832004006	1	Set of spacers (3 pieces **, Thickness = 1, 2, 3 mm.)

TAB. 05

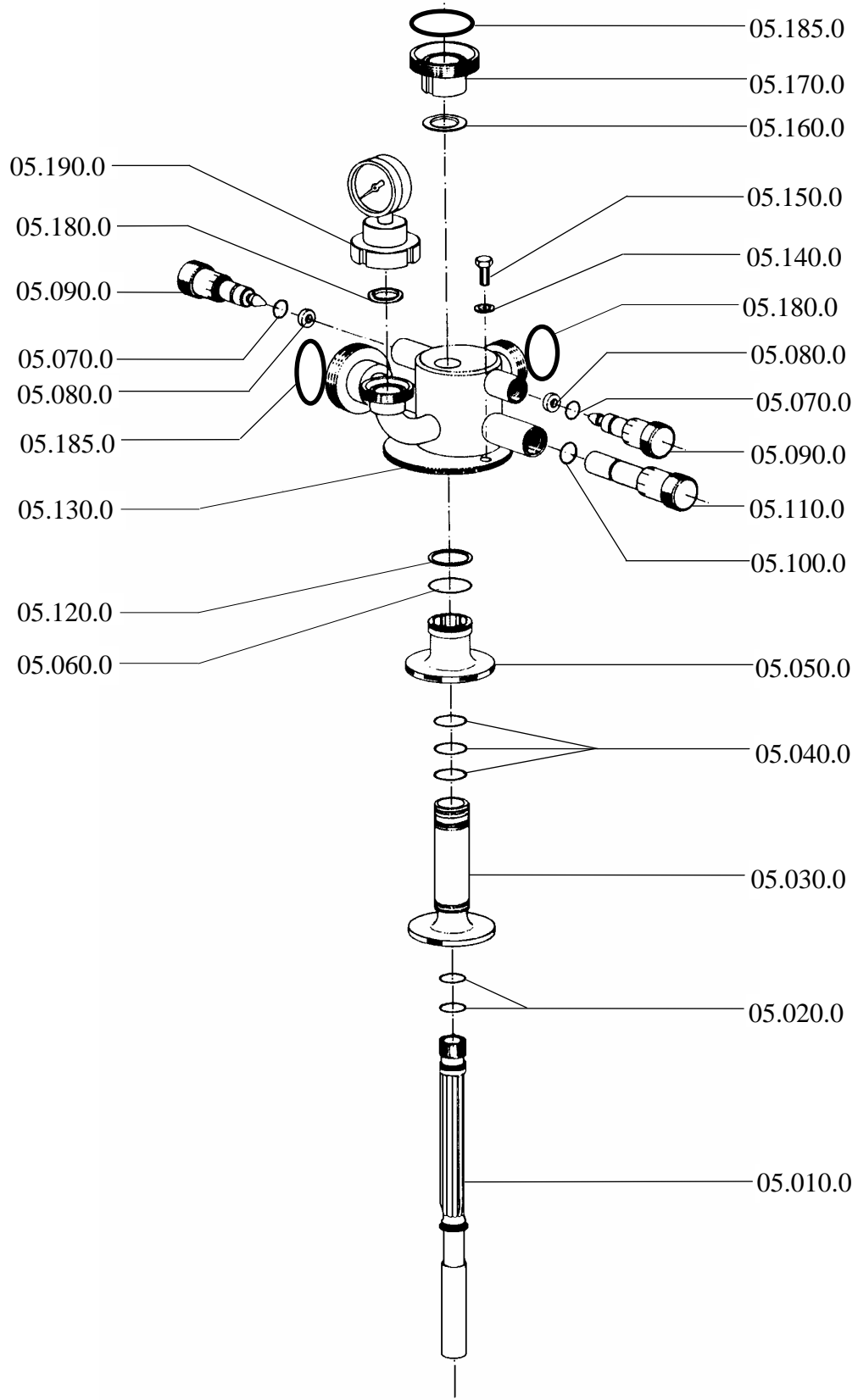

VERTICAL SHAFT - TAB. 06

<u>Reference</u>	<u>Code</u>	<u>Quantity</u>	<u>Description</u>
06.010.0 **	528020420	1	OR gasket - bush
06.020.0	300092000	1	Bush
06.030.0	529010150	3	Screw - bush
06.040.0	529056506	3	Washer - bush
06.050.0	400175700	1	Lower spring
06.060.0	400232200	1	Spheric support
06.070.0	400040700	1	Bush - thrust bearings
06.080.0 *	521075445	1	Couple of thrust ball bearings
06.090.0 *	400210900	1	Washer - thrust bearings
06.100.0 *	521050450	1	Self-aligning ball bearing
06.110.0 *	400210800	1	Washer - self-aligning bearing
06.120.0	529066006	2	Ring nut
06.130.0 ***	300512400	1	Helical pinion (<i>8.000 rpm - 50 Hz.</i>)
06.140.0	300000100	1	Vertical shaft
06.150.0 *	521040267	1	Upper ball bearing
06.160.0 *	400207500	1	Washer - upper ball bearing
06.170.0	300020400	1	Frame ring
06.180.0	400023100	1	Spacer - upper ball bearing
06.190.0	300019200	1	Collar
06.200.0 **	528020456	1	OR gasket - collar cage
06.210.0	400031700	6	Buffer
06.220.0	400753800	6	Buffer spring
06.230.0	400092300	6	Buffer screw
06.240.0	200146500	1	Collar cage
06.250.0 **	528020540	1	Gasket - cage cover
06.260.0	300076100	1	Cage cover
06.270.0	529056512	3	Washer - cage cover
06.280.0	529001158	3	Screw - cage cover
06.290.0 **	528020197	1	OR gasket - labyrinth
06.300.0	400171000	1	Labyrinth
06.510.0	832005015	1	Set of vertical shaft ball bearings and washers (6 pieces,*)
06.520.0	832001007	1	Set of vertical shaft gaskets (4 pieces,**)
06.530.0	832007029	1	Set of gears, flanges and screws for helical wheel (06.130.0 *** + 07.190.0 ÷ 07.230.0 ***, 12 pieces)
06.540.0	832012000	1	Set of buffers (6 pieces, 06.210.0)
06.550.0	832012009	1	Set of buffer springs (6 pieces, 06.220.0)
06.560.0	832012002	1	Set of buffer screws (6 pieces, 06.230.0)

TAB. 06

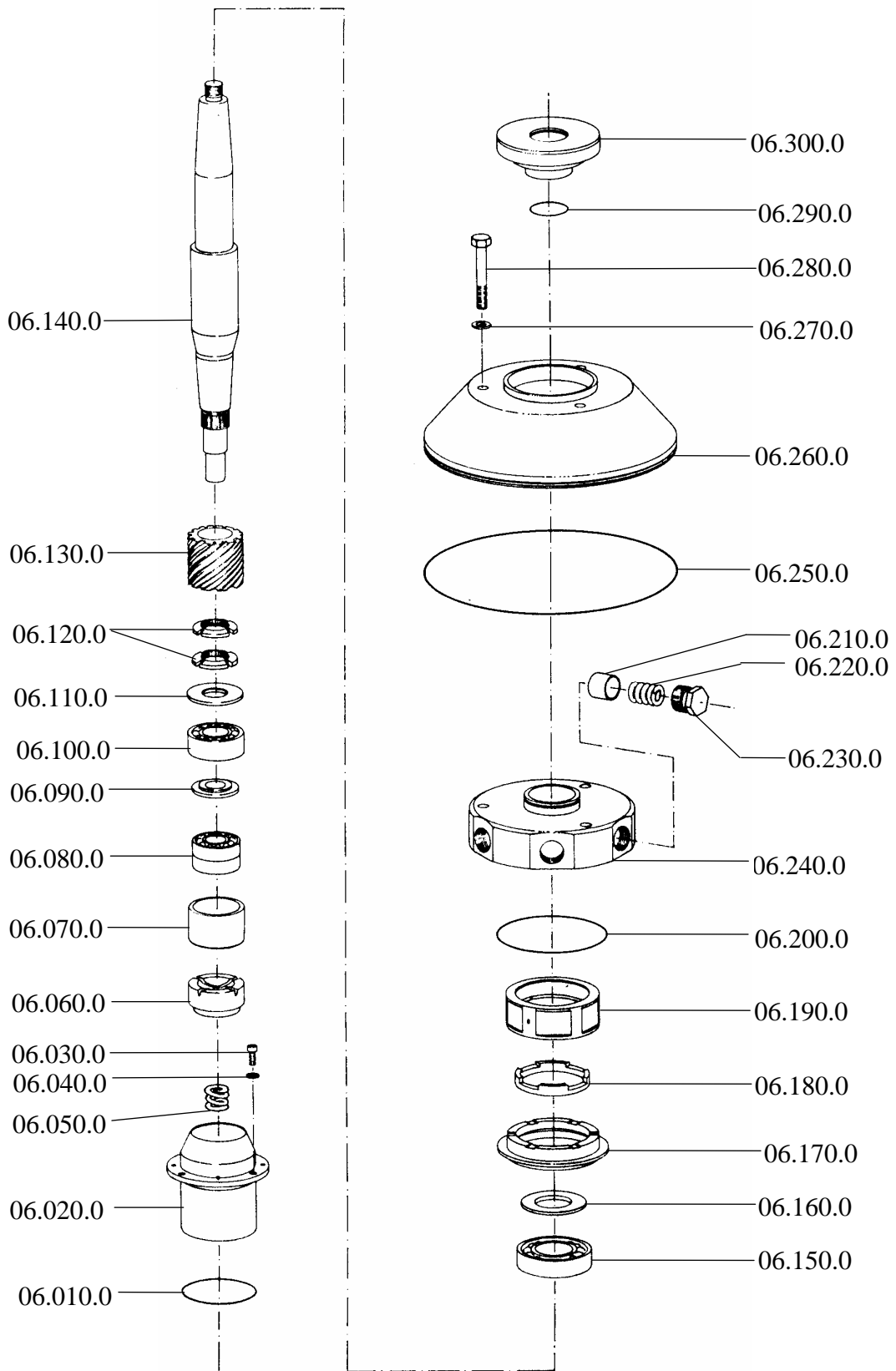

HORIZONTAL SHAFT - TAB. 07/A

<u>Reference</u>	<u>Code</u>	<u>Quantity</u>	<u>Description</u>
07.010.0	526085421	1	Motor 5,5 kW
07.020.0	529006188	4	Motor screw
07.030.0	529056512	4	Washer
07.040.0	400197500	1	Shoe holder
07.050.0	529023202	1	Expanding pin - shoe holder
07.060.0	400046900	3	Clutch-shoe
07.070.0	529011208	1	Screw - flange
07.080.0	400134400	1	Motor flange
07.090.0	200233700	1	Horizontal shaft
07.100.0	529071148	2	Drive pin - tachometer
07.110.0	529005114	4	Screw - support
07.120.0	529055508	4	Washer
07.130.0 **	528000561	1	Seal ring
07.140.0	300143300	1	Support - clutch side
07.150.0 **	528020435	1	OR gasket - clutch side support
07.160.0 *	521000270	1	Ball bearing - clutch side
07.170.0 *	529090585	1	Circlip - ball bearing
07.180.0 *	529090045	1	Circlip - horizontal shaft
07.190.0 ***	400125200	1	Flange (threaded holes) - gear wheel
07.200.0 ***	300512300	1	Helical gear wheel (8.000 rpm - 50 Hz.)
07.210.0 ***	400125500	1	Flange - gear wheel
07.220.0 ***	529055012	4	Washer
07.230.0 ***	529000158	4	Screw - gear wheel
07.240.0 *	529090580	1	Circlip - ball bearing
07.250.0 *	521000265	1	Ball bearing - tachometer
07.260.0 **	528020522	2	OR gasket - tachometer side support
07.270.0	300143801	1	Support - tachometer side
07.280.0	529023256	2	Dowel (only for painted models)
07.290.0	/	1	Cover (only for stainless steel lined models)
07.300.0	529056010	4	Washer
07.310.0	529006156	4	Screw - support
07.320.0 **	400212700	1	Nylon washer
07.330.0 **	528151020	1	Gasket - tachometer oil guard
07.340.0	400231500	1	Tachometer
07.350.0	400149100	1	Ring nut - tachometer
07.510.0	832005007	1	Set of horizontal shaft ball bearings and circlips (5 pieces,*)
07.520.0	832001009	1	Set of horizontal shaft gaskets (6 pieces,**)
07.530.0	832011004	1	Set of clutch-shoes (3 pieces, 07.060.0)
06.530.0	832007029	1	Set of gear, flanges and screws for helical wheel (06.130.0 *** + 07.190.0 ÷ 07.230.0 ***, 12 pieces)

TAB. 07/A

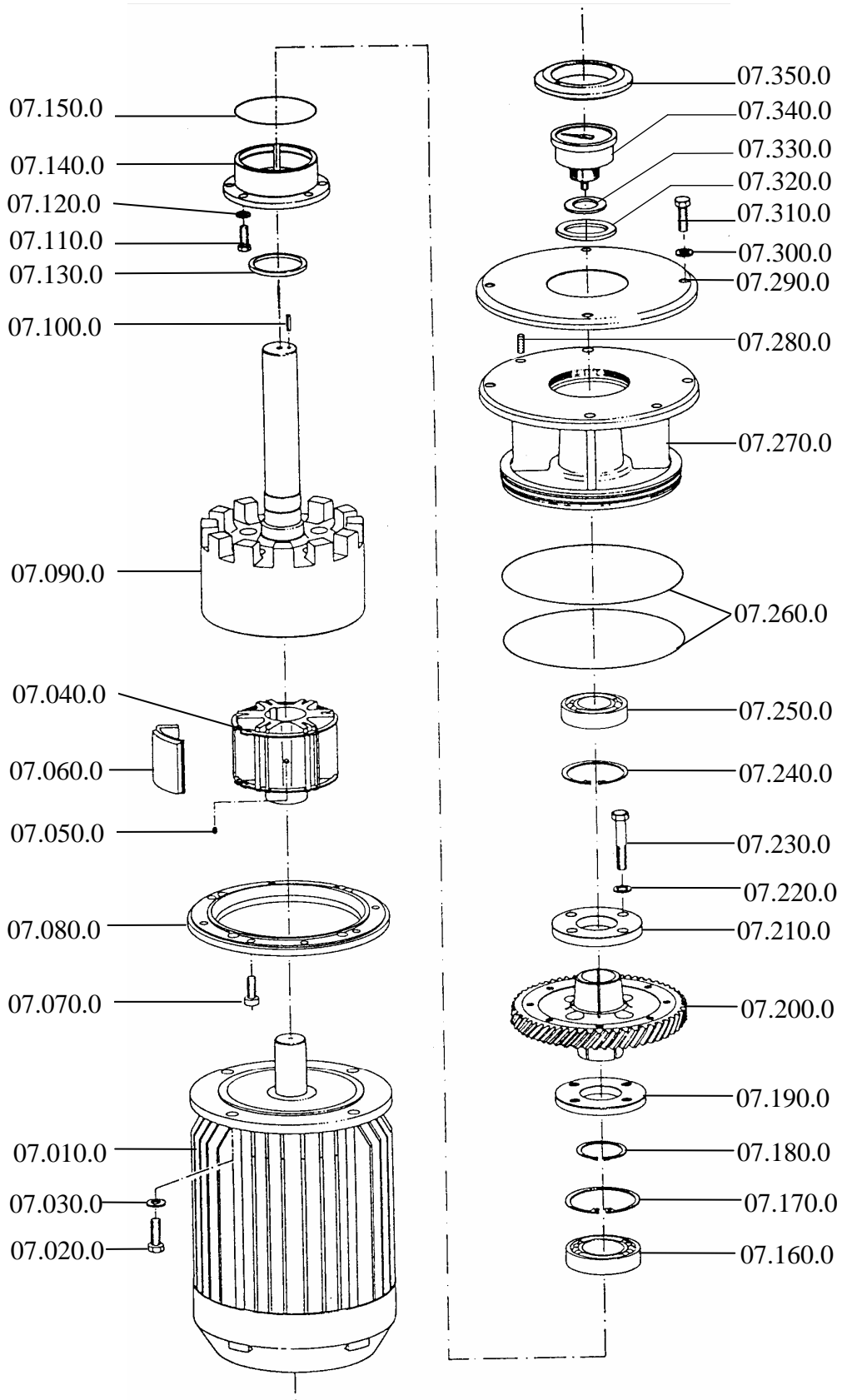

HORIZONTAL SHAFT UNIT - MOTOR
TAB. 07/B

<u>Reference</u>	<u>Code</u>	<u>Quantity</u>	<u>Description</u>
07.400.0	/	1	Shaft with rotor
07.410.0	/	2	Seal ring
07.420.0	/	1	Cover
07.430.0	/	1	Eyebolt
07.440.0	/	1	Fan cap
07.450.0	/	1	Cover
07.460.0	/	1	Fan
07.470.0	/	1	Screw
07.480.0	/	1	Nut
07.490.0	/	1	Washer
07.500.0	/	4	Stay bolt
07.510.0	/	12	Nut
07.520.0	/	2	Ball bearing
07.530.0	/	1	Tank with wound stator
07.540.0	/	1	Feather key
07.550.0	526085421	1	Motor 5,5 KW

TAB. 07/B

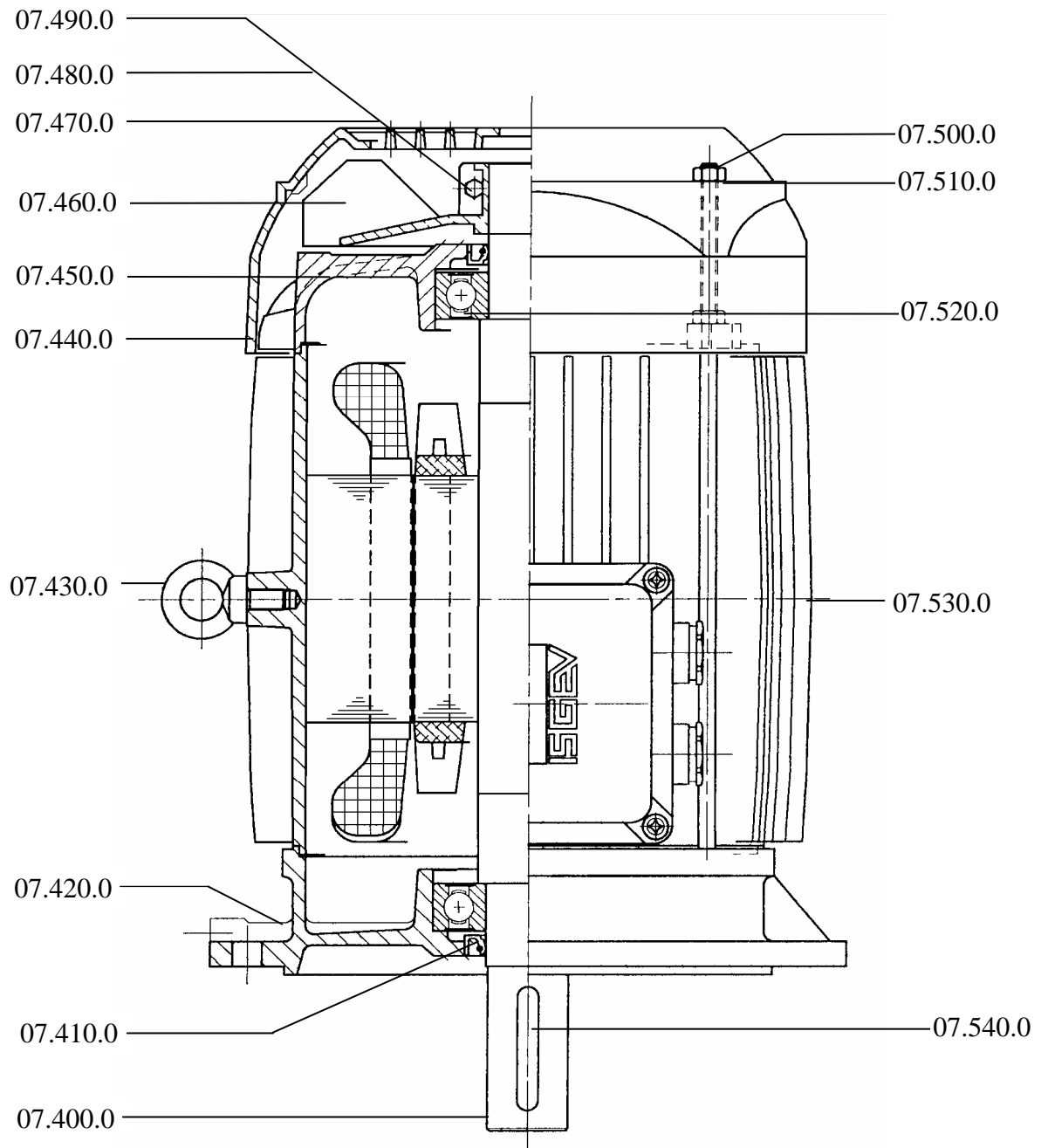

FRAME - TAB. 08

<u>Reference</u>	<u>Code</u>	<u>Quantity</u>	<u>Description</u>
08.030.0	529056006	4	Washer
08.040.0	529006076	4	Screw - brake flange
08.050.0	529070355	1	Brake elastic pin Ø6x16
08.060.0	521580020	1	Brake hand wheel
08.070.0 *	400046800	1	Brake shoe with pin (included elastic pin 08.050.0)
08.080.0	529099169	26	Brake spring
08.090.0	400125100	1	Brake flange
08.100.0	529011146	3	Motor cover screw
08.110.0	529056006	3	Washer
08.120.0	300584301	1	Motor cover
08.130.0	529061116	4	Cap nut
08.140.0	529056016	4	Washer
08.150.0	400213800	4	Nylon washer
08.160.0	400121100	4	Shock absorber
08.170.0	808011002	1	Foundation plate
08.180.0	400234300	2	Plug for oil supply/drain
08.190.0	400211200	2	Plug gaskets
08.200.0	528020444	1	Gasket
08.210.0	400135100	1	Internal flange - gear chamber
08.220.0	400125700	1	External flange - gear chamber
08.230.0 **	400320300	2	Gaskets
08.240.0 **	400258900	1	Sight glass - gear chamber
08.250.0	529011154	4	Screw
08.260.0	529061116	2	Cap nut
08.270.0	529056016	2	Washer
08.280.0	400174500	2	Clamp
08.290.0	400242700	2	Threaded rod
08.300.0	400165600	2	Handwheel
08.310.0	400182000	2	Locking pin
08.320.0	529070151	2	Pin Ø3x25
08.330.0	400037500	2	Threaded bush
08.340.0	100605010	1	Cover
08.345.0	528020702	1	OR gasket - cover
08.510.0	400046800	1	Brake shoe with pin and elastic pin (08.070.0)
08.520.0	832020003	1	Sight glass with gaskets (3 pieces, *)
08.530.0	832016500	1	Set of shock absorbers (4 pieces, 08.160.0 **)

TAB. 08

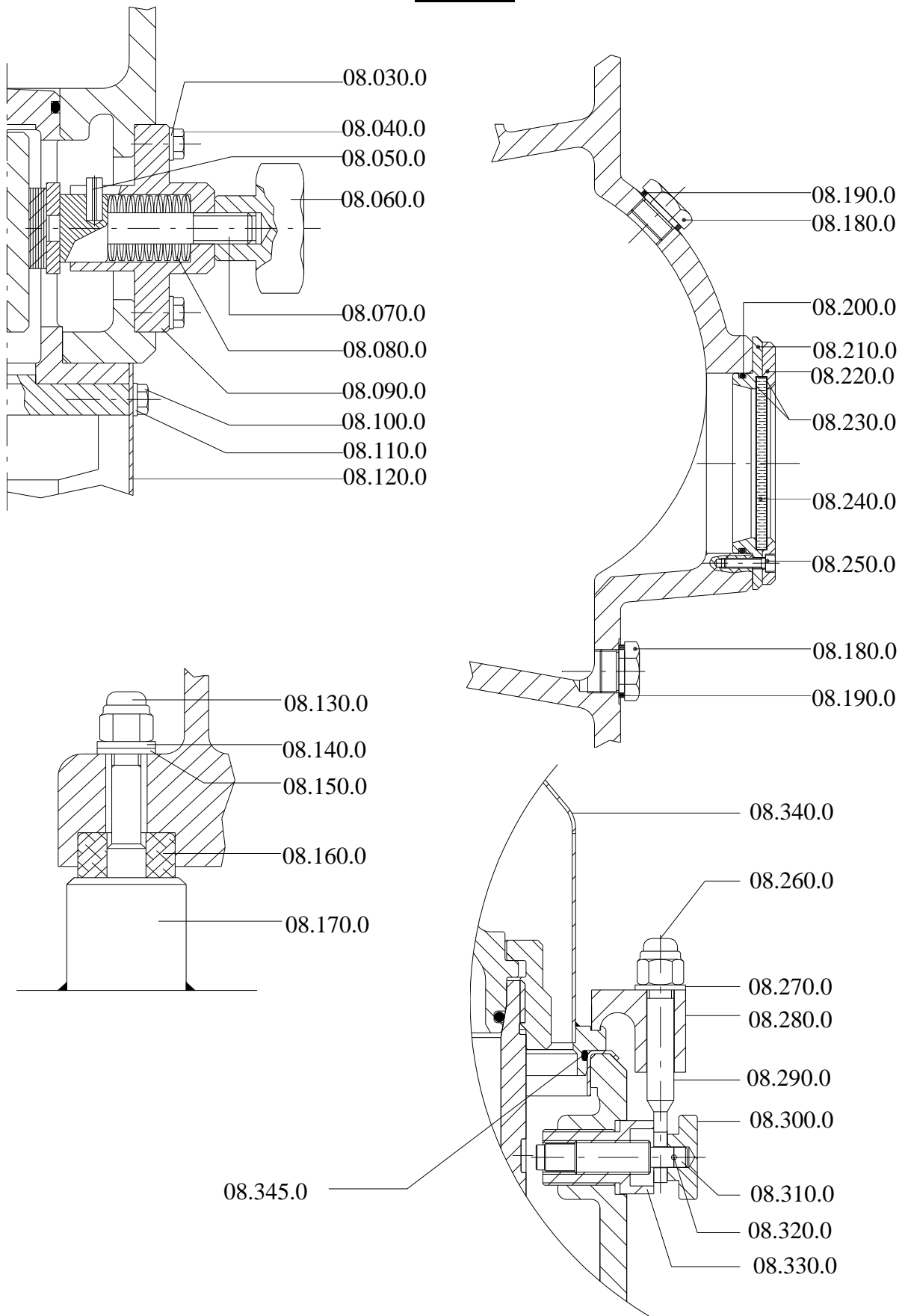

SPECIAL SPANNERS - TAB. 09

<u>Reference</u>	<u>Code</u>	<u>Quantity</u>	<u>Description</u>
09.010.0	400053000	1	Spanner for lifting of bowl hood
09.020.0	400053800	1	Spanner for big lock ring
09.030.0	400056000	1	Mallet
09.040.0	400352600	1	Spanner for bowl body nut (40/42)
09.050.0	560040545	1	Spanner for feeding pipe nut (45/50)
09.060.0	560040135	1	Spanner for small ring (135/145)
09.070.0	400217700	1	Spanner for feeding pipe
09.080.0	400054900	1	Spanner for lifting bowl body and distributor
09.090.0	560000017	1	Spanner 17 - screws of inlet-outlet flow unit
09.100.0	560000024	1	Spanner 24 - cover screws
09.110.0	560000032	1	Spanner 32 - plugs supply / drain oil
09.120.0	564900080	1	Oil funnel

TAB. 09

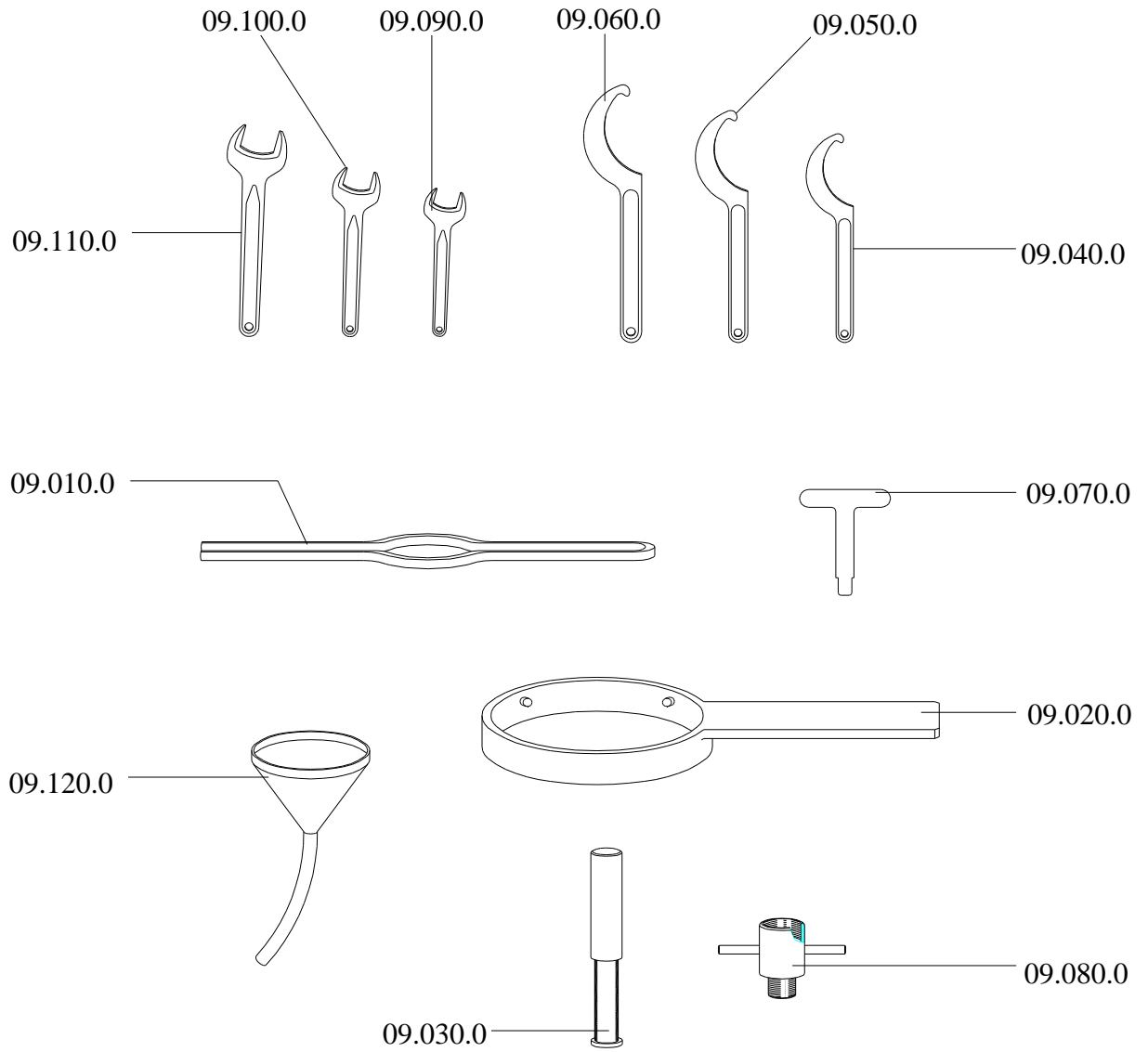

IDENTIFICATION PLATES AND ALERT STICKERS FREE NECESSARY AREA - TAB. 22

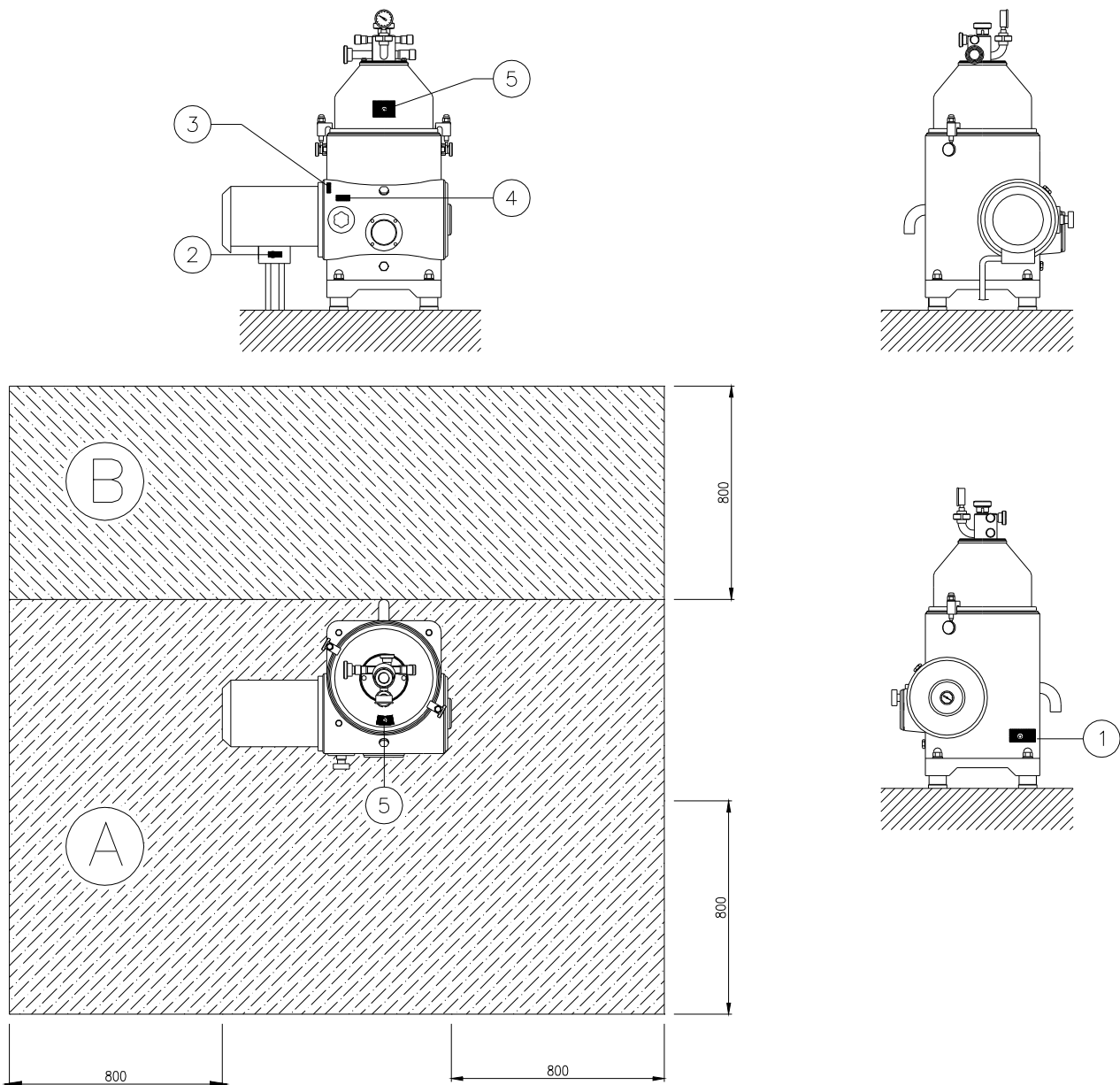

- 1 Plate with technical and identification data of separator.
- 2 Sticker - motor connection voltage.
- 3 Plate with motor direction of rotation.
- 4 Plate with brake direction of activation.
- 5 Sticker - safety alert.

A Free necessary area for normal operation.
A+B Free necessary area for maintenance.

SPARE PARTS REQUEST FORM

Centrifugal separator mod.: SE 07..... Manufacturing N°:

Mark with a X the requested spare parts and indicate the selected quantity.

<u>Ref.</u>	<u>Code</u>	<u>Quantity</u>	<u>Description</u>
<i>Bowl (Tab. 04)</i>			
<input type="checkbox"/>	04.510.0	832000016 Set of bowl gaskets (3 pieces)
<input type="checkbox"/>
<i>Inlet-outlet flow unit (Tab. 05)</i>			
<input type="checkbox"/>	05.010.0	300251700 Feeding pipe
<input type="checkbox"/>	05.030.0	400196700 Lower pump - cream
<input type="checkbox"/>	05.050.0	400302900 Upper pump - skim
<input type="checkbox"/>	05.190.0	520060210 Manometer
<input type="checkbox"/>	05.510.0	832000018 Set of gaskets with gaskets for fittings DIN (16 pieces)
<input type="checkbox"/>	05.520.0	832004006 Set of spacers (3 pieces)
<input type="checkbox"/>
<i>Vertical shaft (Tab. 06)</i>			
<input type="checkbox"/>	06.510.0	832005015 Set of vertical shaft bearings and washers (6 pieces)
<input type="checkbox"/>	06.520.0	832001007 Set of vertical shaft gaskets (4 pieces)
<input type="checkbox"/>	06.530.0	832007029 Set of gears (12 pieces)
<input type="checkbox"/>
<i>Horizontal shaft (Tab. 07)</i>			
<input type="checkbox"/>	07.510.0	832005007 Set of horizontal shaft bearings and circlips (5 pieces)
<input type="checkbox"/>	07.520.0	832001009 Set of horizontal shaft gaskets (5 pieces)
<input type="checkbox"/>	07.530.0	832011004 Set of clutch-shoes (3 pieces)
<input type="checkbox"/>
<i>Frame (Tab. 08)</i>			
<input type="checkbox"/>	08.510.0	400046800 Brake shoe with pin and elastic pin (2 pieces)
<input type="checkbox"/>	08.520.0	832020003 Sight glass with gaskets
<input type="checkbox"/>	08.530.0	832016500 Set of shock absorber (4 pieces)
<input type="checkbox"/>

SPARE PARTS REQUEST FORM

Centrifugal separator mod.: SE 07..... Manufacturing N°:

Mark with a X the requested spare parts and indicate the selected quantity.

<u>Ref.</u>	<u>Code</u>	<u>Quantity</u>	<u>Description</u>
<i>Bowl (Tab. 04)</i>			
<input type="checkbox"/>	04.510.0	832000016 Set of bowl gaskets (3 pieces)
<input type="checkbox"/>
<i>Inlet-outlet flow unit (Tab. 05)</i>			
<input type="checkbox"/>	05.010.0	300251700 Feeding pipe
<input type="checkbox"/>	05.030.0	400196700 Lower pump - cream
<input type="checkbox"/>	05.050.0	400302900 Upper pump - skim
<input type="checkbox"/>	05.190.0	520060210 Manometer
<input type="checkbox"/>	05.510.0	832000018 Set of gaskets with gaskets for fittings DIN (16 pieces)
<input type="checkbox"/>	05.520.0	832004006 Set of spacers (3 pieces)
<input type="checkbox"/>
<i>Vertical shaft (Tab. 06)</i>			
<input type="checkbox"/>	06.510.0	832005015 Set of vertical shaft bearings and washers (6 pieces)
<input type="checkbox"/>	06.520.0	832001007 Set of vertical shaft gaskets (4 pieces)
<input type="checkbox"/>	06.530.0	832007029 Set of gears (12 pieces)
<input type="checkbox"/>
<i>Horizontal shaft (Tab. 07)</i>			
<input type="checkbox"/>	07.510.0	832005007 Set of horizontal shaft bearings and circlips (5 pieces)
<input type="checkbox"/>	07.520.0	832001009 Set of horizontal shaft gaskets (5 pieces)
<input type="checkbox"/>	07.530.0	832011004 Set of clutch-shoes (3 pieces)
<input type="checkbox"/>
<i>Frame (Tab. 08)</i>			
<input type="checkbox"/>	08.510.0	400046800 Brake shoe with pin and elastic pin (2 pieces)
<input type="checkbox"/>	08.520.0	832020003 Sight glass with gaskets
<input type="checkbox"/>	08.530.0	832016500 Set of shock absorber (4 pieces)
<input type="checkbox"/>

SPARE PARTS REQUEST FORM

Centrifugal separator mod.: SE 07..... Manufacturing N°:

Mark with a X the requested spare parts and indicate the selected quantity.

<u>Ref.</u>	<u>Code</u>	<u>Quantity</u>	<u>Description</u>
<i>Bowl (Tab. 04)</i>			
<input type="checkbox"/>	04.510.0	832000016 Set of bowl gaskets (3 pieces)
<input type="checkbox"/>
<i>Inlet-outlet flow unit (Tab. 05)</i>			
<input type="checkbox"/>	05.010.0	300251700 Feeding pipe
<input type="checkbox"/>	05.030.0	400196700 Lower pump - cream
<input type="checkbox"/>	05.050.0	400302900 Upper pump - skim
<input type="checkbox"/>	05.190.0	520060210 Manometer
<input type="checkbox"/>	05.510.0	832000018 Set of gaskets with gaskets for fittings DIN (16 pieces)
<input type="checkbox"/>	05.520.0	832004006 Set of spacers (3 pieces)
<input type="checkbox"/>
<i>Vertical shaft (Tab. 06)</i>			
<input type="checkbox"/>	06.510.0	832005015 Set of vertical shaft bearings and washers (6 pieces)
<input type="checkbox"/>	06.520.0	832001007 Set of vertical shaft gaskets (4 pieces)
<input type="checkbox"/>	06.530.0	832007029 Set of gears (12 pieces)
<input type="checkbox"/>
<i>Horizontal shaft (Tab. 07)</i>			
<input type="checkbox"/>	07.510.0	832005007 Set of horizontal shaft bearings and circlips (5 pieces)
<input type="checkbox"/>	07.520.0	832001009 Set of horizontal shaft gaskets (5 pieces)
<input type="checkbox"/>	07.530.0	832011004 Set of clutch-shoes (3 pieces)
<input type="checkbox"/>
<i>Frame (Tab. 08)</i>			
<input type="checkbox"/>	08.510.0	400046800 Brake shoe with pin and elastic pin (2 pieces)
<input type="checkbox"/>	08.520.0	832020003 Sight glass with gaskets
<input type="checkbox"/>	08.530.0	832016500 Set of shock absorber (4 pieces)
<input type="checkbox"/>