

TREPKO Sp. z o.o.
ul. Roosevelta 116, 62-200 Gniezno, Poland

tel. (+48 61) 426 50 41; fax (+48 61) 426 50 18, e-mail: trepko@trepko.pl www.trepko.com

Trepko

MW
MACHINERY WORLD

**Operating and Maintenance
Instructions**

**PACKING MACHINE for BUTTER,
LARD and MARGARINE**

typ

XPG-40

GNIEZNO 2012

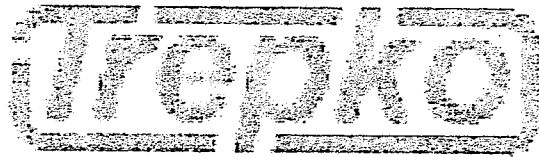

XPG 40

Based on BENHIL 8380

Date of rebuilt

Serial no.

Made in EU

Contents

	page
0. Introduction	1
1. Application	2
2. Technical characteristic	2
3. Transportation, setting on site and connecting of the machine	2
3.1. Transportation	2
3.2. Setting the machine	3
3.3. Reassembly of units disassembled before transportation of the machine	3
3.3.1. Assembly of worm tray	3
3.3.2. Assembly of conveyor	4
3.3.2.1. Conveyor positioned in parallel to the packing material path	4
3.3.2.2. Conveyor positioned perpendicular to the packing material path	5
3.4. Connecting to power supply	5
4. Description of machine design	5
4.1. Drive unit	6
4.2. Closing unit	7
4.2.1. Cake overturn device	7
4.3. Batcher of worm feeder	7
4.4. Batcher of direct connection	8
4.5. Batcher of feeding funnel	8
4.6. Feeder drive	9
4.7. Conveyor	9
4.7.1. Cake setting unit	10
4.8. Revolving table with rectangular pockets	10
4.8.1. Revolving table with round pockets for	

	format 100 ^{110 × 62.6} × 75	10
4.9.	Revolving table with round pockets for format 95 x 63,5 x 44	11
4.10.	Worm feeder	11
4.11.	Feeding funnel	12
4.12.	Direct connection	12
4.13.	Paper unit	12
4.13.1.	Forming punch drive	13
4.13.2.	Bending unit complete	13
4.13.3.	Feeding rollers	13
4.13.4.	Transport rollers	13
4.13.5.	Paper feeder	14
4.13.6.	Mechanical centring device	14
4.13.7.	Knife drive	15
4.13.8.	Sensor of paper feeding	15
4.13.9.	Brake and date stamp	15
4.13.10.	Paper pusher	16
4.14.	Case pusher	16
4.14.1.	Equipment for format 95 x 63,5 x 44	16
4.14.2.	Equipment for format 100 × 75 × 35 ^{110 × 62.6 × 45}	16
4.14.3.	Equipment for format 75 x 50 x 35	17
4.15.	Shields	17
4.16.	Plunger base	17
4.17.	Wiring system	17
5.	Description of machine operation	17
6.	Service elements	20
7.	Lubrication	25
7.1.	Lubrication of main gear	25
7.2.	Lubrication of worm drive	25

7.3.	Lubrication of gear box for batch size change	25
7.4.	Lubrication of cam paths, rollers and guides	26
7.5.	Lubrication of slide bearings equipped with ball greaser	26
7.5.1.	Lubrication frequency for slide bearings	26
7.6.	Lubrication of rolling bearings, type Fafnir bearings and joints type SF and SM	26
7.6.1.	Lubrication frequency for rolling bearings	26
7.7.	Lubrication of the variable-speed transmission disk	27
7.8.	Lubrication of some batcher parts, when packing fatless products	27
7.9.	Maintenance	27
8.	Packing machine test running, without packing material	27
9.	Installing of packing material band and setting up the paper unit	28
9.1.	Initial activities before installing the packing material	28
9.2.	Packing material guidance unit	29
9.3.	Setting of the mechanical centring unit	29
9.4.	Switching on the mechanical band feeding	30
9.5.	Setting the date stamp	30
9.6.	Setting the limit switch for paper lack signaling and the paper sensor	31
9.7.	Removing of the band	31
10.	Perturbations in the paper unit working	31

10.1.	Cutting off the paper outside the middle of perforation hole - the register finger does not come into hole	31
10.2.	The overprint is not located in centre of the package surface	31
10.3.	Incorrect cutting of packing material	32
10.4.	Incorrect supply of packing material to the revolving table	32
11.	Assembly of feeding worms	33
12.	Packing start, troubles and adjustments	33
12.1	Preparation of packing machine for packing	33
12.2.	Perturbations during package filling	35
12.3.	Back suction device - principle of operation and adjustment	36
12.4.	Adjustment of the cutting bow cam	37
12.5.	Operating the closing unit	37
13.	Operating the batching cylinder, the batching plunger and the compensation plunger	38
14.	Setting up for packing of butter	38
15.	Packing of cottage cheese	40
16.	Cleaning	40
17.	Reconstruction of packing machine for another format / not applied to version for format 95 x 63,5 x 44 /	42
17.1.	Format change from 100 x 75 mm to 75 x 50 mm / from 250 g to 125 g/	42
17.2.	Format change from 75 x 50 to 100 x 75 / from 125 g to 250 g /	44
18.	Change of the worm rotation speed	44

19.	Replacement of the conveyor band	45
20.	Replacement of knives for cutting the packing material	46
20.1.	Disassembly of lower knife	46
20.2.	Disassembly of upper knife	46
20.3.	Sharpening of knives	47
20.4.	Assembly of upper knife	47
20.5.	Assembly of lower knife	47
21.	Replacement of lubrication hose	47
22.	Operating the variable-speed belt transmission	48
23.	Guidelines regarding service, inspections and repairs of the machine	48
23.1.	General remarks	48
23.2.	Operating the machine	49
23.3.	Technical inspection	49
23.4.	Adjustment guidelines for possible disassembly and assembly of the packing machine	50
23.5.	Repairs	50
23.6.	Specification of spare parts	51
24.	Work safety rules	52
25.	Work movement diagram	53
26.	<i>Electrical diagram</i>	55
27.	<i>Foil guide manual instruction</i>	59
28.	<i>Perforating date stamp</i>	64

Enclosure No 1 - Requirements regarding the packing material

Enclosure No 2 - Spare parts catalogue

Trepko

Version "S"

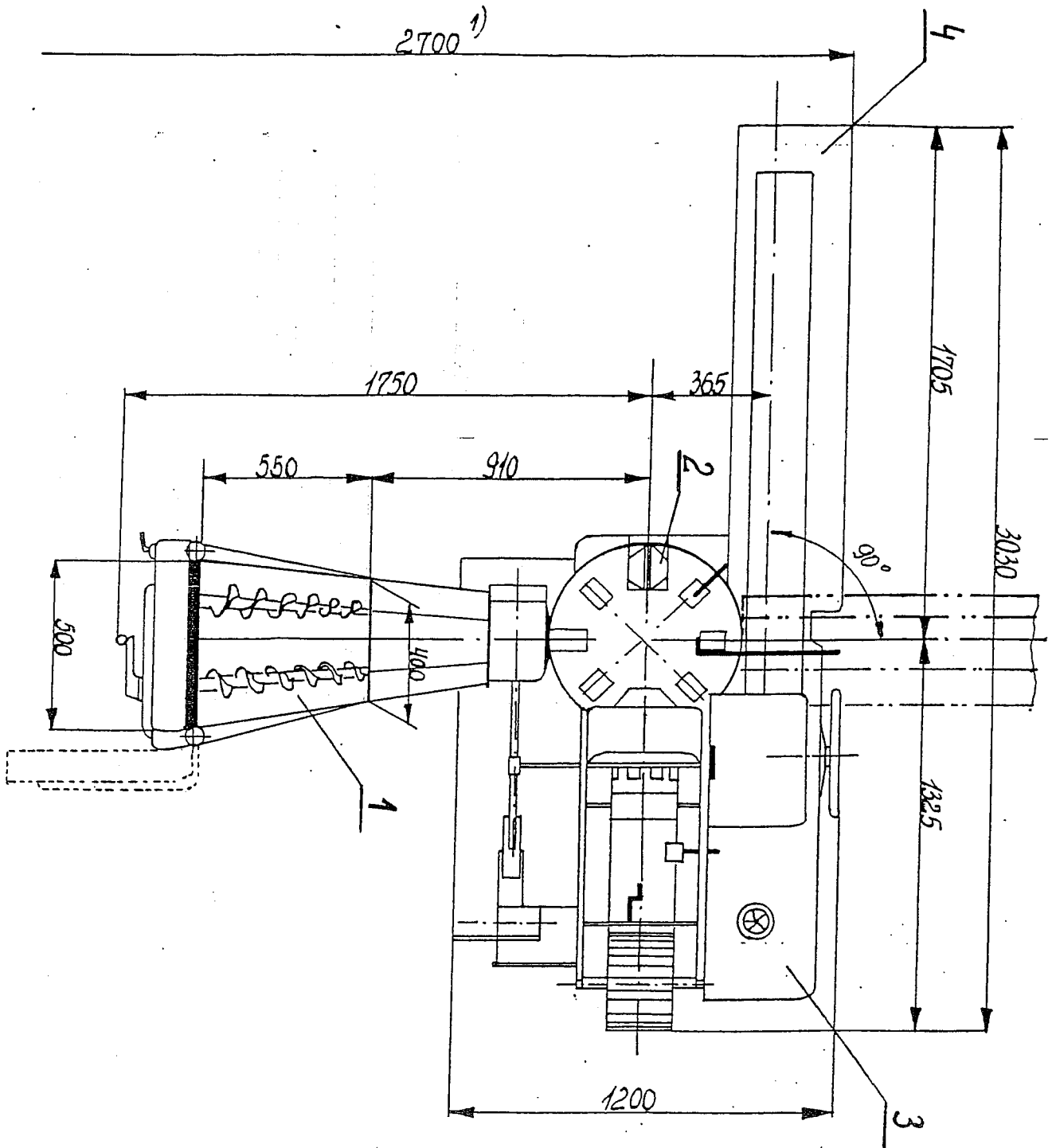

Trepko

Version "T"

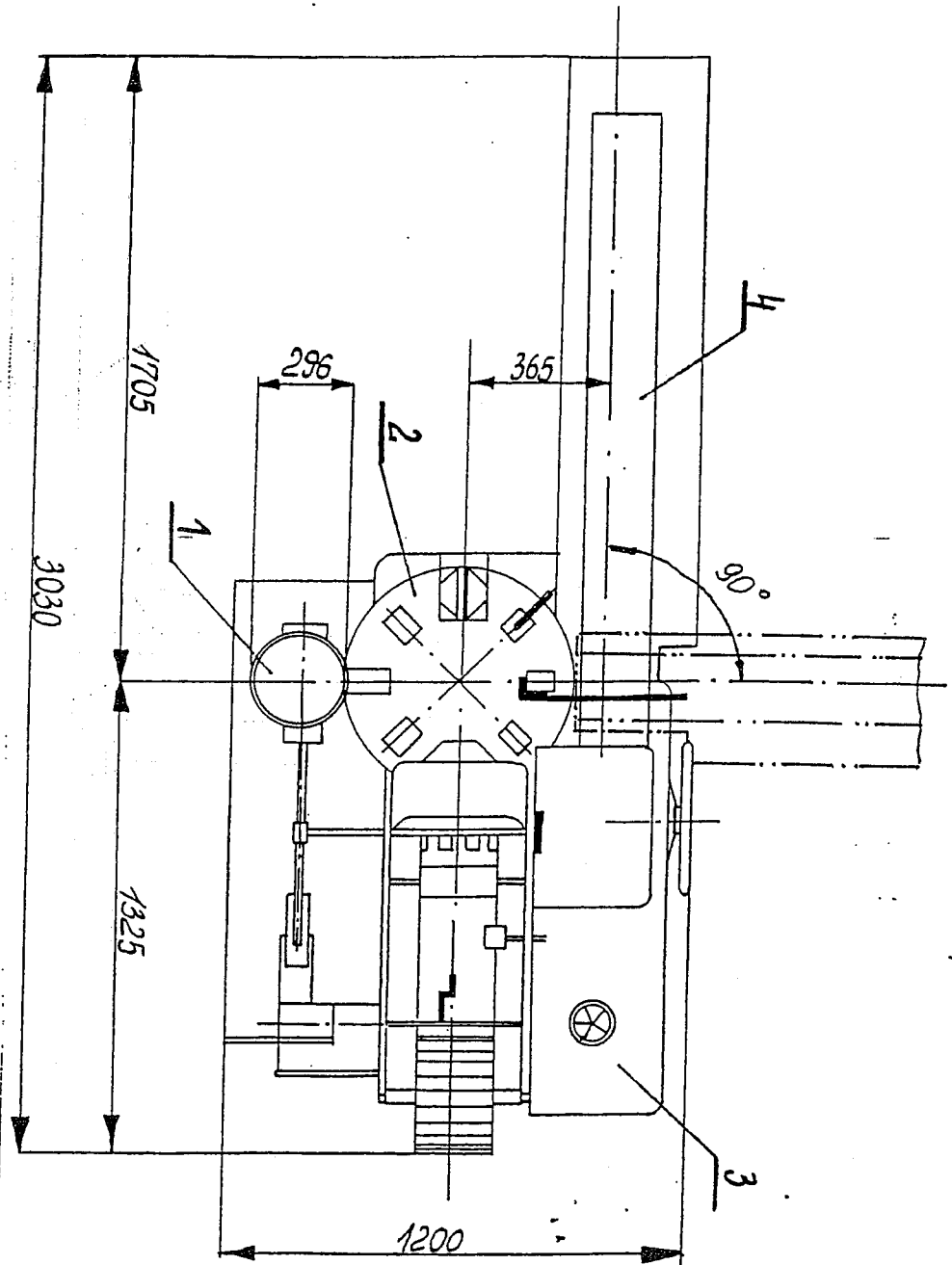

Trepko

Version "D"

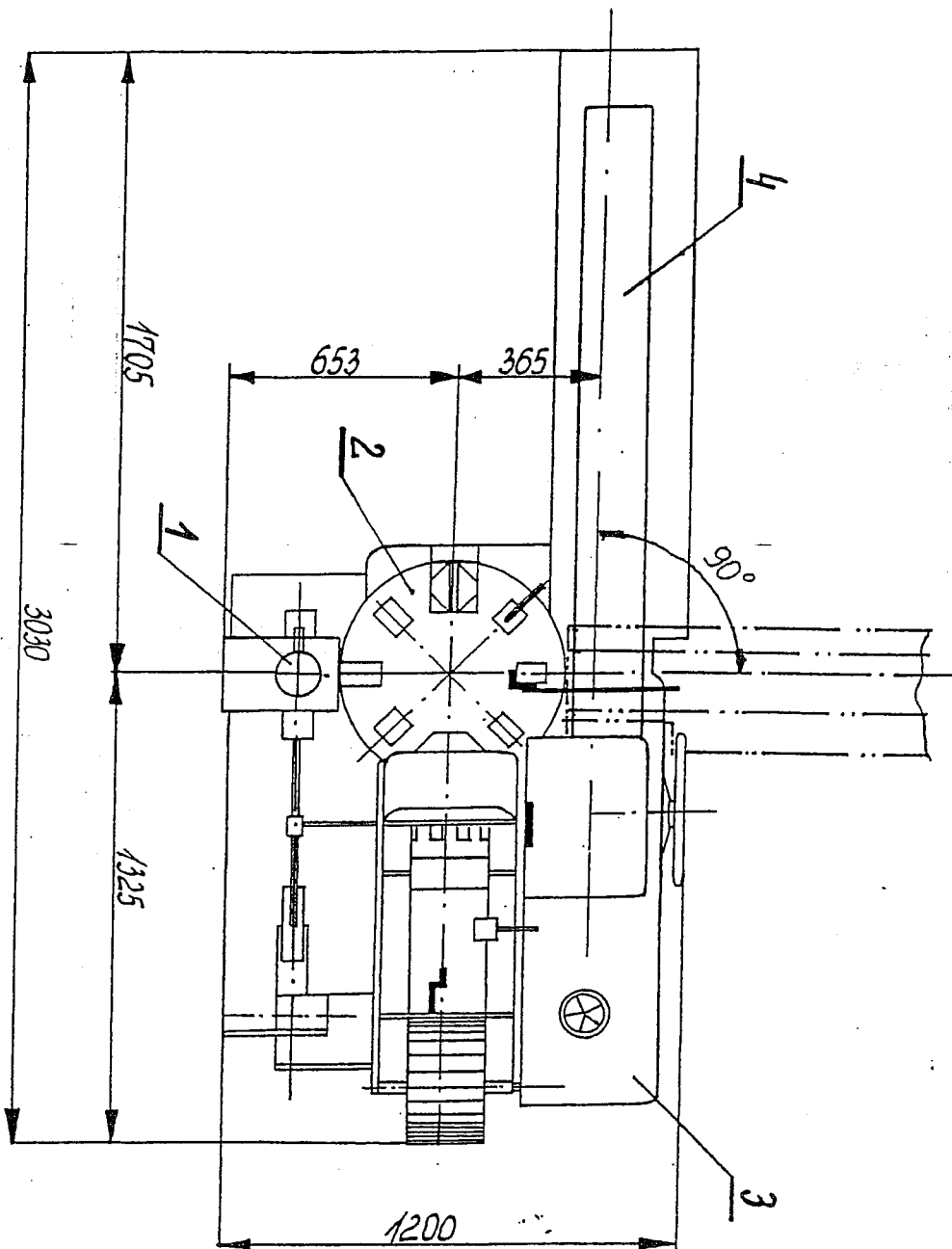

O. Introduction

O.1. These Operating and Maintenance Instructions refer to packing machine type XPG 40, versions S, T or D.

Version S - with worm feeder

Version T - with feeding funnel

Version D - with direct connection

Versions S and T are produced in 3 forms:

Form I - for cakes 250g and 125g, with format 100 x 75 and
75 x 50

Form II - for cakes 250g, format 110×62.6
~~100 x 75~~ only

Form III - for cakes 125g, format 75 x 50 only

O.2. Informations and recommendations regarding putting the machine into operation

a/. Before execution of any activities related with putting the machine into operation, please acquaint yourself with content of this operation manual.

b/. Place the machine on its site.

c/. Assemble elements disassembled for transportation.

d/. Connect the power supply to the control box.

e/. Start putting the packing machine into operation.

Notes: 1. The packing machine has been tested by manufacturer on the idle run only, without filling the packages

2. The user is obliged to commission the manufacturer to put the packing machine into operation / guaranty requirement/. The manufacturer's service personnel carries out following work on this special user's order:

- installing the machine on the site

- putting the machine into operation and adjustment

for packing of particular product

- commissioning the machine
- instructing the machine operators

1. Application

The packing machine type XPG 40 is used for batching and packing butter, lard, margarine, cottage cheese into aluminium foil or parchment paper.

2. Technical description

- capacity of the machine up to 90 packages/min.
- cake size / for butter and lard/
 - cake 250g - $110 \times 62.6 \times 45$
~~100 x 75 x 35 mm~~
 - ~~cake 125g - 75 x 50 x 35 mm~~
- ~~or for margarine~~
 - cake 250g - ~~95 x 63,5 x 44mm~~
- power rating - 2,2 kW
- weight - ca 1600 kg
- overall dimensions - 3030 x 2700 x 1800

3. Transportation, setting on site and connecting the machine

3.1. Transportation

The packing machine is transported in state of partly disassembly. The machine can be packed in box or be fastend to transport beams. The packing machine equipment is transported in separate box. When the machine is carried by means of open transport facilities, it should be protected against weather conditions by means of polyethylene foil or canvas paulin.

The machine can be lifted by means of 4 eye bolts located at legs. Put 2 bars with diameter ca 50 mm into bolt eyes and hang ropes with diameter ca 36 mm on these bars / use the hemp rope /. The packing machine can also be lifted by means of fork lifter.

The fork length must be minimum 1600 mm.

Note: Do not hang the ropes on levers, shafts or similar parts, protruding from the packing machine.

When shifting the machine, use round bars and put them under the transport beams.

3.2. Setting the machine

After removing the package and transport beams, set the packing machine on its place of use. Then level the revolving table in all directions with accuracy of $\pm 0^{\circ}15'$ by means of adjusting bolts located in the legs. After leveling, secure the adjusting bolts with lock nuts.

The machine anchoring is not needed.

Check / by repeated turning the hand wheel /, if there are any failures caused by transportation of the machine. If any failure is stated, make a complaint of this at manufacturer or carrier.

3.3. Reassembly of units disassembled before transportation of the machine

3.3.1. Assembly of worm tray

The flanges of worm tray Cat.No /Catalogue Number/ 13-3 and of batcher body Cat.No 04-10 / or 05, or 06 - depending on version/ should be degreased and immediately before assembly smeared with water-glass on the adherent surfaces. Fasten both connectors Cat.No 13-28 to the side plate of main machine. Put the washers under the legs. Shift the worm tray to the batcher body, and after matching the nicks, connect initially /light/ with 4 bolts. Loosen the securing ring and key of drive shaft Cat.No 13-25. Put the shaft into bearing flange and set in horizontal position by means of adjusting bolts Cat.No 13-14. Fasten the connector Cat.No 13-28 to the support beam Cat.No 13-16. Tighten up all the bolts. Put the key, chain wheel and securing ring on the

drive shaft behind the side plate Cat.No 01-73. Check, if chain wheels are in the same plane. Strike with hammer and punch the sleeve in bearing flange and the retaining ring. Tighten up the stud-bolt .Put on the chain / do not overtighten/.

Put the feeding worms into the tray according to chapter 11 of this instruction. Put the complete base Cat.No 13-29 with strips Cat.No13-30 - for arrangement of batching cylinder.

3.3.2. Assembly of conveyor Cat.No 01/3 and 08

Connect the band conveyor for carrying the packed cakes away with the main machine in such a way, that bevel gear Cat.No 01/3-9 is in mesh with bevel gear Cat.No 01/3-8. Then put the tapered pins into side walls Cat.No 01/3-12 and 01/3-13 and fasten strong by means of bolts with connector Cat.No 01/3-17. Set the conveyor in correct direction /chapter 3.2.1 and 3.3.2.2 of this instruction/. Fasten the leg complete Cat.No 08-1 on the conveyor's end. Level by turning the leg adjusting bolt. Stretch the conveyor band / see chapter 19/.

3.3.2.1. Conveyor positioned in parallel to the packing material path

Loosen the bolts of the cam overturn cam Cat.No 01/3-14. Turn the cam to the stop in counterclockwise direction, when looking from the top and then tighten the bolt. Set the lever Cat.No 01/3-10 by turning the hand drive wheel in the top position. The cake overturn device Cat.No 19-9 /or 20-9 or 18-9/ must then be set horizontally. If the setting is not horizontal, correct it by displacement of the shaft Cat.No 03-7.

Put the connector of the cake pusher Cat.No 17-10 on the joint head. The cake pusher must not rotate during the movement of lever Cat.No 17-3. Correct the deviations by means of the connector Cat.No 17-10.

3.3.2.2. Conveyor positioned perpendicular to the packing material path

Loosen the bolts of the cake overturn device Cat.No 01/3-14. Turn the cam in clockwise direction, when looking from the top and then tighten the bolt again. Check and correct, if needed, the setting of the cake overturn device Cat.No 19-3 /or 20-9, or 18-9/ according to the guidelines of chapter 3.3.2.1.

Put the connector Cat.No 17-10 on the joint head. The cake pusher Cat.No 19-4 / or 20-4, or 28-4/ must turn by 90° during the motion of the lever Cat.No 17-3. Correct the deviation by means of connector Cat.No 17-10.

3.3.3. Put the shaft with rollers Cat.No 16/3-7 and 8 into the open from the top side bearing Cat.No 16/3-6 and 16/3-9. Put the packing material shaft Cat.No 16/5-1 into recess at the end of the paper unit side walls.

3.4. Connecting to power supply

The packing machine should be connected to 380/220 V, 50 Hz, AC mains. Carry out the grounding or neutral earthing. Check the motor revolutions direction. It should be consistent with direction of arrow on the drive hand wheel.

4. Description of machine design

The packing machine performs selfacting all the activities connected with forming the package, wrapping the cake and transportation of cakes to the place of hand packing into the cardboard boxes or to cartoning machine type XKG 41. The working elements, performing these activities, are driven by cam mechanisms.

The packing machine consists of following units:

drive unit

closing unit

cakes overturn device
batcher of worm feeder
batcher of direct connection
batcher of feeding funnel
feeder drive
conveyor
cake setting unit
revolving table with rectangular pockets
revolving table with round pockets for format $110 \times 62.6 \times 45$
~~100 x 75 x 35~~
~~revolving table with round pockets for format 95 x 63,5 x 44~~
worm feeder
feeding funnel
direct connection
paper unit
pusher
~~equipment for format 95 x 63,5 x 44~~
equipment for format $110 \times 62.5 \times 45$
~~100 x 75 x 35~~
~~equipment for format 75 x 50 x 35~~
standard shields / or coordinated /
plunger base
electric equipment

4.1. Drive unit - Cat.No 01-01/8

This unit ensures drive for all the packing machine mechanisms. It consists of the body, which is support structure for the electric motor with brake. This motor drives all the packing machine units. The drive is transmitted through the variable-speed belt transmission and gears on the cam shafts. The worm tray is driven through the chain transmission. The conveyor is driven through the chain transmission and gear transmission with bevel and cylindrical gears.

4.2. Closing unit - Cat.No 02

The unit consists of some levers with paddles for bending the packing material on the batched dose. The closing unit is driven by cam mechanism through the levers and connectors.

Note: When the packing machine is equipped for two formats / 250g and 125g/, two sets of closing unit are delivered. They are changed as unit during the machine reset.

4.2.1. Cakes overturn device - fig. 03

The cakes overturn device consists of the shaft with overturn element and chain wheel, located on the shaft end. The chain is pulled by the lever and causes the halfturn of the overturn element. The return to start position is ensured by the spring, mounted on the other end of the chain. The cake overturn device turns the cakes by 180°, that means, with overprint turned up. This cakes position on the conveyor protects them against unwrapping.

4.3. Batcher of worm feeder - version "S" - fig. 04

The batcher consists of the body with cylinder and batching plunger mounted inside. In the upper part of the body compensation plunger and elements of the knife drive are located. The drive of batching plunger is shown on figure 07. The plunger feeds the packed product to the filling cock. Here the product is batched by cutting the bar, which is pressed out. The knife drive is shown on the figure 07/1. The compensation plunger is used in order to absorb or feed the product, depending on actual needs. It works under action of push spring. The packing machine is equipped by the manufacturer with 3 kinds of spring, which can be changed according to the packed product consistence.

Note: 1. The manufacturer can deliver two kinds of batcher:

- standard form

- the version without copper impurity / for products, which react with copper /
- 2. The batcher of worm feeder can co-operate with worm feeder only / figure 13/
- 3. The use of worm feeder is recommended, when packing butter or lard

4.4. Batcher of direct connection - *version „D”*

The batcher of direct connection is used only with special packing machine form. It is designed alike the batcher of worm feeder. The difference consists in fact, that instead of worm tray, it is connected through the appropriate connecting pipe with pipe instalation, feeding the packed product. The task of compensation plunger is the same, like in the batcher of worm feeder, but only one spring is used.

Note: 1. The manufacturer can deliver two kinds of batcher:

- standard form or version without copper impurity / for products, which react with copper contained in batcher elements/
- 2. The batcher of direct connection can co-operate with the direct connection unit /figure 15/ only.
- 3. The use of this batcher is recommended, when packing margarine

4.5. Batcher of feeding funnel - *version „T”*

The batcher of feeding funnel is used with special machine form only. It is designed alike the batcher of worm feeder. The difference consists in fact, that the product is feeded through the funnel from the top. The drive of the plunger and the knife is similar like in the batcher of worm feeder. The batcher of feeding funnel is not equiped with compensation plunger.

- Note: 1. The manufacturer can deliver two kinds of batcher:
standard form or version without copper impurity
/ for products, which react with copper contained
in batcher elements/
2. The batcher of feeding funnel can co-operate with the
feeding funnel /figure 14/ only
3. The use of this batcher is recommended, when packing
fat or cheese with very soft consistence

4.6. Feeder drive - Fig.07

The feeder drive unit consists of the cutoff drive, the cylinder rotation drive and the mouthpiece drive.

The cutoff mechanism consists of cam with co-operating lever, of strip connector and slideway. With the slideway co-operates the knife lever.

The cam mechanism drives the slideway, which performs the reciprocating movement. The cylinder rotation mechanism consists of lever with co-operating cam, of connector, intermediate lever, shaft and toothed segment. The toothed segment is in mesh with tothing on the batching cylinder.

When the cam rotates, the toothed segment performs pendulous movement, and as consequence - the cylinder half-turn left and right.

The cock lifting mechanism consists of lever with co-operating cam. To the lever the connector is fixed. The other connector's end is fixed to the mouthpiece. When the cam rotates, the mouthpiece is shifted down and up.

4.7. Conveyor - Fig.08

The conveyor consists of table, transport band, band stretcher, transport roller and leg.

The table lies with its one end on the main machine, and with

the other - on the leg. In the end part of the table the roller is located. On this roller the transport band rewinds. The second roller is located in the drive unit /Fig.01/3/. In the lower part of the conveyor the band stretcher is mounted. The conveyor transports the packed cakes away.

4.7.1. Cake setting unit

The cake setting unit is used, when 125g cakes are packed and the packing machine type XPG 40 is connected with cartoning machine XKG 41. The unit is fixed over the conveyor by means of two hinges and can be turned aside, when 250g cakes are packed. The cake setting unit consists of some guides, electromagnetic servo and guide lever. The servo is controlled by micro-switch mounted on the main machine and co-operating with revolving table. The cake setting unit is used for arrangement the cakes into two lines.

4.8. Revolving table with rectangular pockets - Fig.10

The main elements of this unit are following: revolving table, ring and bottom guide. The revolving table is driven by cam mechanism / Fig.01/5 /. The bottom guides move in the ring, which carries out reciprocating movement in vertical direction. The guides movement is caused by appropriate configuration of path, on which guide rollers move.

In the revolving table the formed package is held down, then filled with packed product. The package is wrapped and then the cake is finally formed by pressing.

Note: When the 125g cakes are packed, in the table pockets special inserts with bore 75 x 50 are mounted and secured against falling out by locks.

4.8.1. Revolving table with round pockets for format 110×62.6
~~100 x 75~~
The revolving table with round pockets for format 110×62.6 is ~~100 x 75~~

an special packing machine form. It is in design almost identical like the table with rectangular pockets. The difference consists in fact, that in the table body round bores are made. In these bores different pockets are mounted, depending on format and size of the cake. In the lower part of the table snap fasteners for securing the pockets against falling out are provided. All other elements are like in previous form. The drive and the appropriation is also the same.

4.9. Revolving table with round pockets for format 95 x 63,5 x 44 - Fig.12

The revolving table with round pockets for format 95 x 63,5 x 44 is an special packing machine form. Its design is identical like of the table with round pockets for format 100 x 75. Only dimensional differences occur. The drive and the appropriation is the same, as for the table with rectangular pockets.

4.10 Worm feeder - Fig. 13 and 13/1

The worm feeder consists of the tray and two worms mounted inside the tray. In the back part the gear box is mounted on the hinges. Thanks to this design, it is possible to open quickly the back wall of the tray and remove the worms /for washing/. Inside the box, toothed wheels for worm drive are mounted. The toothed wheels are driven by transmission shaft from the main machine. Two toothed wheels can be changed, when the packing machine is resetted from one format to another, or when products with different consistence are packed. Therefor the worms /in standard form/ have 4 rotation speeds. The worm feeder supplies the packed product to the batcher cylinder.

Note: The worm feeder can co-operate with the batcher of worm feeder / Fig.04 / only.

4.11. Feeding funnel - Fig.14 - version "T"

The feeding funnel is a special packing machine form. It consists of the funnel mounted on the batcher body /Fig.06/. Inside the funnel the feeding worm, driven by separate electric motor is provided. The switch on and switch off push-button for this motor is located on the control desk.

Note: The feeding funnel can co-operate with the batcher of feeding funnel /Fig.06/ only.

4.12. Direct connection - Fig.15 - version "T"

The direct connection is a special packing machine form and is used, when the packing machine is incorporated into process line. It consists of pipe with union piece, connecting the preceding device with the packing machine batcher.

Note: The direct connection can co-operate with the batcher for direct connection /Fig.05/ only.

4.13. Paper unit - Fig.16

The main elements of the paper unit are two side walls, on which following assemblies are mounted:

- forming punch drive
- bending unit complete
- feeding rollers
- transport rollers
- paper feeder
- mechanical centring device
- knife drive
- sensor of paper feeding
- brake and date stamp
- paper pusher

The paper unit is used for feeding the packing material into forming head.

4.13.1. Forming punch drive - Fig.16/1

The forming punch is driven by cam mechanism from the drive unit. In consequence the punch carries out reciprocating move in vertical direction. The forming punch push the cut off packing paper or foil through the forming head /Fig. 18/1, 19/1, 20/1/. In consequence the package in form of top open box is formed and placed in the revolving table pocket.

4.13.2. Bending unit complete - Fig.16/2

The bending unit consists of cam, lever with roller, axle and lever with preform bender. All the unit /except cam/ is mounted on the shaft in the sub-assembly of feeding rollers /Fig.16/3/. The bender carries out the preform bending of packing foil or parchment paper and holds it in the forming head during package forming.

4.13.3. Feeding rollers - Fig.16/3

The feeding rollers unit consists of two pairs of rollers, supported in bearings mounted in side walls. On the upper shaft two rolls and gear are mounted. On the lower shaft two half-round segments and two gears are mounted. The rolls and the segments shift the cut sheet of packing material to the forming head. They are driven from the drive unit /Fig.01/ through the gears.

4.13.4. Transport rollers - Fig.16/4

The transport rollers unit consists of two shafts supported in bearings mounted in side walls. On the shafts transport rollers are mounted.

The upper shaft is equipped with lift for lifting it, when packing material is put between the rollers and for switching off the paper supply. The transport rollers are driven from the drive unit through the gears.

The transport rollers feed the packing material to the feeding

rollers. Because feeding rollers have on the part of their perimeter reduced radius and adjustable perimeter length, packing material is feeded on required length by steps, while the shafts rotate continuously.

4.13.5. Paper feeder - Fig. 16/5 and 16/6

The paper feeder unit consists of paper reel axle, on which the packing paper reel is placed, of feeding rollers, of brake, which prevents self-acting unreeling of packing material, of ratched coupling connected with transport rollers and of lever mechanism for stop switch, complete with rocker. In the side part interlock lever for control unit of packing material feeding is mounted. In this sub-assembly is also mounted the chain stretcher of feeding rollers drive.

The packing material /parchment paper or foil/ is unrolled from the reel by means of feeding rollers. Then passes it under the rocker roller and over the constant cross-bar with brake.

If transport rollers, pulling the packing material, cause rocker's shift to the top, the lever mechanism switches the coupling on and packing material is unrolled by feeding rollers. When suitable paper rate is supplied, the rocker moves down and switches off the coupling. The rollers stop paper feeding. Thus coupling switching on and switching off causes self-acting adjustment of packing material feeding. In case of packing material lack, the rocker lever falls completely down, the plate switches off the microswitch and packing machine stops.

4.13.6. Mechanical centring device - Fig.16/8

The mechanical centring device consists of two guides and the finger. The guides enable setting the finger in suitable place in relation to packing material. The finger, in co-operation

with the foil withdraw bow, after finding the perforation, determines the length of packing material cut off.

The mechanical centring device is used only when packing products in foil with individual overprint. The foil must be perforated / holes \emptyset 10/ with pitch equal the length of foil cut off for one package. In the case, when packing material is overprinted continuously, the centring device must be switched off.

4.13.7. Knife drive - Fig.16/9

The knife drive sub-assembly consists of following details: cam with co-operating lever, clamp, the upper and the lower knife packing material guide and two springs, pulling the lower knife to the upper one.

When the cam rotates, the lower knife makes reciprocating movement in vertical direction. The upper knife stays motionless.

The knives cut off the packing material.

4.13.8. Sensor of paper feeding - Fig.16/10

This sub-assembly consists of following elements: cam with co-operating lever and sensor complete. The main part of the sensor is insulated pin, connected with one pole of current source.

The second pole is connected to the ground. When the cam rotates, the sensor moves down and up. In the lowest position the sensor touches the forming head. If on the forming head packing material occurs, it is the insulating layer and the current does not pass. In the moment, when packing material ends, the pin touches direct the forming head, the passage of current occurs, opening the contactor. The packing machine stops.

4.13.9. Brake and date stamp - Fig.16/11 and 16/12

The main part of the brake is roller with one-way coupling. The roller is mounted on the rotary clamp and can be lifted up. All the part lies on the longitudinal and transverse guides and

therefor can be adjusted in all directions.

The brake prevents the back motion of packing material.

The date stamp is mounted on the side wall of the paper unit.

The working elements are needles, which punch the date on the moving packing material. The date is set by means of pin, delivered as packing machine equipment. The date stamp is driven by cam mechanism.

4.13.10. Paper pusher - Fig.16/13

In the sub-assembly of the paper pusher the main parts are two ejectors, which through the lever system co-operate with two cams. This design ensures its rotation simultaneously with its lifting or lowering. The stroke size is adjustable. The ejectors cause the final packing material shift on the forming head.

4.14. Cake pusher - Fig.17

The cake pusher is mounted on the side wall of the paper unit, on special support. The main part are: lever with ejector and cam mechanism, driving this lever.

The cake pusher shifts the packed cakes from the revolving table to the cakes overturn device.

4.14.1 Equipment for format 95 x 63,5 x 44 - Unit XPG40-18-00-00

The equipment for format 95 x 63,5 x 44 consists of forming head for the packing material and of some working elements, mounted in various machine parts. The unit is mounted by the machine manufacturer. It is impossible to reset the packing machine for another format.

4.14.2. Equipment for format ^{110 x 62,6 x 45}~~100 x 75 x 35~~ - Unit XPG40-19-00-00

The equipment consists of forming head for the packing material and of other elements, which size connected with cake format and which are mounted in various machine parts. The unit is mounted by the machine manufacturer. ~~The machine user can reset~~

~~the machine for format 75 x 50 x 35.~~

4.14.3. Equipment for format 75 x 50 x 35 - Unit XPG40-20-00-00

The design and the parts are alike the format 100 x 75 x 35. This equipment is delivered by the machine manufacturer on special order.

4.15. Shields - Unit XPG40-21-00-00

The moving packing machine parts are covered with shields, which secure the servicing personnel against accident, protect the moving elements against access of foreign matters and are decorative elements. They are made from steel sheets and Metaplex. On user's order, the shields can be made from stainless steel. The shields are fixed to the main machine by means of bolts. The shields, which should be removed before greasing machine elements, are provided with information plates and holders / ball knobs /.

4.16. Plunger base - Unit XPG40-23-00-00

It consists of two vee blocks, connected by two rods, on which the batcher cylinder and the plunger lie, when packing machine is cleaned. The plunger base is delivered with form D and T only. In form S, the vee blocks are mounted solid at the worm tray.

4.17. Wiring system - Unit XPG40-24-00-00

The main elements of the wiring system are control desk and distribution box. In the control desk control push-buttons, signal elements and drive interlock are mounted. The drive interlock is active, when the front shield, made from Metaplex, is open. In the control box control, securing and distribution elements of the wiring system are located.

The wiring system is shown on enclosed diagrams.

5. Description of machine operation

The co-operation of particular packing machine units is described

in chapter 4 - Description of machine design. The packing process of single cake proceeds as follows:

a/ Stand I - Package forming

The packing material is unwrapped from the reel and shift to the knives. The foil sheet, cut off on the proper length, is feeded to the forming head. The plunger, moving vertically down, pushes the foil through the forming head. The package in form of rectangular prism is formed and put into the revolving table pocket. The forming head in its lower part on the front side is equiped with press rollers, pulled by springs, which press the formed bends. They are used for parchment paper or thicker foil. When thin foil is used, the press rollers action can be switched off by pressing down the latch levers, located on the both head sides. The rollers action can be switched on by pushing the levers up.

Under the forming head adjustable package scraper is mounted. It prevents taking the package along with moving up plunger. The plunger comes back to the start position, the revolving table turns and formed package is shifted to the next stand.

b/ Stand II - Batching

The product is sucked in by retracting plunger from the feeding unit into batching cylinder and, after cylinder turn, is pressed out by plunger through the mouthpiece. In this time the mouthpiece moves down and comes into formed package in the pocket of the revolving table. When the product is pressed out, the mouthpiece moves up and after ending the package filling, the product coming out from the mouthpiece is cut off.

The product supply to batching cylinder, depending on the kind of feeder, used according to consistence of packed product, is carried out as follows:

- in form S - the product is supplied by means of two horizontal worms, rotating in suitably shaped tray. The tray can be filled by hand or by means of any conveyor /band, pump, worm feeder et
- in form T - the product is supplied through the funnel with one vertical worm. The funnel filling - alike in form S.
- in form D - the product is supplied directly into cylinder through the pipe and under pressure of 1,5 at. e.g. directly from an device of product process line, or by pump.

c/ Stand V - Wrapping

At first the shorter package sides are bended. This operation is carried out by two benders, which move in direction parallel to the table radius. Then one longer side is bended by the bender moving in direction perpendicular to the table radius. The fourth side is bended during the table rotation, when the package passes under the solid plate.

d/ Stand VI - Pressing down

On this stand the wrapped cake is pressed down by the punch. Thereby the overlaps are pressed down to the packed product and the cake is finally shaped.

e/ Stand VII - Cake taking off

The bottom of the revolving table pocket pushes the packed cake from the pocket on the table surface. The cake scraper shifts it on the overturn device. Here the cake is turned by 180° /overlaps down/ and put on the conveyor.

f/ On the stands II, IV and VIII of revolving table no operations of cake packing process are carried out. The above described operations on particular stands are performed simultaneously. Therefore, during one cycle, when the head turns by $1/8$ of revolution, one cake is packed.

6. Service elements

No	Part name	Fig. in catalog	Appropriation	Service position - adjustment actions
1	2	3	4	5
1	Adjusting screw	01-1	Pressure adjustment	Turning right causes pressure increase Turning left causes pressure decrease
2	Adjusting screw	01-7	Adjustment of the revolving table bottoms on bending stand	The top surface of the pack should protrude ca 1mm over the revolving table surface. Turning in the bigger cake size direction causes lowering of the bottom, and in the smaller cake size direction - lifting of the bottom
3	Mandrel	01-37	Switching off the toothed segment, when disassembling the batching cylinder	Pull the ball knob and turn the rack Cat.No 07/4-6 in the counterclockwise direction
4	Set block	01-39	Setting of cake height on the filling stand in accordance with chapter 12.2	Turning in the bigger cake size direction causes lowering of bottom in the revolving table pocket, and in the smaller cake direction - lifting of the bottom / 1,61 on the scale corresponds to 1mm in true/
5	Arm	01/1-5	Change of batcher capacity - reset lever for co-operation with cam	See chapter 17.1.2

1	2	3	4	5
6	Lever	01/2-2	Batcher switching on and switching off	Right lever position "0" - batcher switched off. Left lever position "I" - batcher switched on
7	Hand wheel	01/4-4	Checking the machine	Turn in arrow direction, when checking the packing machine
8	Lever	07/1-6	Adjustment of cutoff lever Fig.18/2, 19/2 20/2	Set the stroke length according to needs. The stroke can be changed by changing the radius on the oval hole in the lever
9	Band stretcher	08-14	Conveyor band stretching	The band deflection is 15 to 20 mm. Loosen the nuts /wrench size 24/, shift the stretcher rollers /wrench size 20/. Tighten the nuts
10	Pin	10-5	Interlock of pusher for the bottoms of revolving table pockets	See chapter 17.1.0
11	Lever rod	13-21	Switching on and switching off the worm tray drive	The lever in "0" position - the drive of worm tray switched off The lever in "I" position - the drive of worm tray switched on
12	Adjusting crank	13/1-17	Worm rotation	The crank turned clockwise - the worms turn "forward". The crank turned counterclockwise - the worms turn "backward"
13	Hand wheel	16-11	Capacity change	Turning in direction "+" - capacity increase Turning in direction "-" - capacity decrease

1	2	3	4	5
14	Lever	16/4-7	Switching on and switching off the transport rollers	The lever switched in direction of revolving table - rollers switched off. The lever lifted in direction of packing material reel - rollers switched on
15	Guide pin	16/5-10	Side guide of packing material	Adjustment depends on the packing material width
16	Lever	16/5-20	Switching on and switching off the packing material band	The lever switched in direction of revolving table - transport switched off. The lever switched in direction of packing material reel - transport switched on
17	Hand wheel	16/7-2	Setting of package weight	Turning in "+" direction - weight increase Turning in "-" direction - weight decrease Note: One turn causes change of 2,5 to 3 gramme
18	Mechanical centring device	16/8	Centre setting of package overprint, when the band with single overprint and perforation holes is used	Adjustment according to packing material used - see chapter 9.3
19	Brake	16/12	Prevents the back motion of the packing material. After switching off, the band removing is possible	The lever switched in direction of revolving table - the brake switched on. The lever switched in direction of packing material reel - the brake switched off

1	2	3	4	5
20	Lever and handle	16/13-9 16/13-11	Adjustment of ejector stroke for feeding the packing paper to forming head	Set the stroke according to needs. The stroke adjustment is made by changing the radius on the lever Fig.16/3-9
21	Pin	17-9	Setting the ejector for parallel action or action with return by 90°	See chapters 3.3.2.1 and 3.3.2.2
22	Lever	18/1-20 19/1-16	Setting the pressure rollers to forming punch and putting them away	Press two bipartite levers vertically down till straightened - the rollers moved away. Lift the levers a little from the both sides - the spring presses the rollers. Press the rollers, when packing into parchment paper. Switch off the rollers, when foil is used
23	Control desk	24-1 Fig.16	Packing machine controls	Switch on the motor by simultaneous pressing of two push-buttons "PRACA". Switch off the motor by pressing the red push-button "STOP". The push-button "RUCH CHWILOWY" is used for instantaneous switching on the machine /for the time, how long it is pressed/. The push-button "HAMULEC WOLNY" - only after pressing of this push-button the turning of hand wheel is possible. Push-button "CZUJNIK" - position "0" - the paper sensor switched off, position "I" - the paper sensor switched on. In the machine

1	2	3	4	5
				<p>form T two additional push-buttons for mixer control are used. Push-button MIESZADŁO "O" - mixer switched off. Push-button "I" - mixer switched on</p>

7. Lubrication

In order to attain good distribution of grease or oil, move the packing machine during greasing by turning the hand wheel. Before lubrication the side shields, provided with information plates, should be removed.

Note: 1. Pay special attention to ball grease nipples, cam rollers and other lubrication places, marked red and located inside the machine

2. Grease before every work the bearings of the cut-off knife lever axle Cat.No 04-24 and 19/2, the slider Cat.No 04-19 and racks Cat.No 07/4-6.

7.1 Lubrication of main gear

For filling the main gear of revolving table ca 35l of oil Hipol 15 is needed. This quantity of oil should reach the level of 3/4 of oil sight-glass.

The used oil, after unscrewing the plug located in the lower part of the body Cat.No 01-16, should be drained into suitable vessel. Screw in the plug again and fill the gear /after removing the plug Cat.No 01-48/ with 20 l of low-viscosity rinsing oil. Switch on the packing machine on idle run for ca 5 minutes. After removing the dirty rinsing oil, fill the gear with new gear oil.

Change the oil for the first time after 300 working hours and then every 3 000 working hours.

7.2. Lubrication of worm drive -Fig.13/1

Pour in ca 1500 g of semi-fluid grease SLP into worm drive box. Change the grease every 500 working hours, after previously rinsing with 5 l of low-viscosity rinsing oil.

7.3. Lubrication of gear box for batch size change

Lubricate the gear box with 50 g of semi-fluid grease SLP every

500 working hours.

7.4. Lubrication of cam paths, rollers, guides, slide blocks, joints, gears, chain wheels, drive chains and marked red holes

All these elements should be lubricated with machine oil 40Z every 10 working hours, using the oiler. The oil stream should be directed between the co-operating surfaces e.g. between the roller and the lever. The oil should also drop on the cam paths or tooting of the gears. When oiler usage is not possible, or if it is more handy, lubricate using the brush /e.g. gears, joints etc./.

7.5. Lubrication of slide bearings equipped with ball greaser

Lubricate the slide bearings with the grease LT4. For lubrication of slide bearings equipped with ball greaser use the grease gun. The bearing can be recognized as greased, when under the action of grease gun, the grease comes out on the front side of the nut.

7.5.1. Lubrication frequency for slide bearings

a/ The high-speed shafts /more, than 100 R/Min/ and levers with high-speed swinging motion should be greased every 4 working hours

b/ The low-speed shafts /below 100 R/Min/ and levers with slow swinging motion should be greased every 8 working hours.

7.6. Lubrication of rolling bearings, type Fafnir bearings and joints type SF and SM

For lubrication of rolling bearings use the grease LT4. The bearings equipped with nipples lubricate using the grease gun. The bearings without nipples grease during disassembly /wash in petrol and put the new grease/.

7.6.1. Lubrication frequency for rolling bearings

a/ Rolling bearings of high-speed shafts - lubricate every

400-500 working hours.

b/ Rolling bearings of low-speed shafts - lubricate every 4000-5000 working hours.

c/ Joints - lubricate according to the needs.

7.7. Lubrication of the variable-speed transmission disk

The disk, fixed on motor shaft, should be lubricated through the nipple using grease No2 every 100 working hours.

Note: Remove carefully every day the grease coming out from the expand disk of V-belt and from the big belt disk.

7.8. Lubrication of some batcher parts, when packing fatless products

Before packing the fatless products /e.g. cottage cheese/ smear in batcher assembly all its moving parts, like cylinder, batching plunger, compensation plunger and slider complete, Cat.No 04-19 with butter, olive oil or other tasteless fat.

7.9. Maintenance

After cleaning, work end or longer standstill, to avoid corrosion, grease all metal parts of the machine. It refers also to electrolytically plated parts /chromium or cadmium plating/ and polished parts e.g. made from aluminium alloys or stainless steel.

8. Packing machine test running without packing material

Every time after lubrication of the machine or execution of other machine service check, if machine run is correct. In first step do it by turning the hand wheel in direction shown by the arrow. If no considerable resistance to motion occurs, the electric drive can be switched on for a short time.

In this purpose proceed as follows:

a/ Close the hinged shield - Cat.No21-4. When the shield is lifted the electric interlock operates and the motor switching on is

not possible.

b/ Close the cover of the wormwheel - Cat.No13/1-4

When the cover is open, the electric interlock operates

c/ Using the connector Cat.No16/5-31, lift and fix the rocker lever-Cat.No16/-28-30 /hook the connector recess on the pawl/.

d/ By means of switcher located on the control desk switch on the packing material sensor.

e/ Switch on the electric motor by means of "RUCH CHWILOWY"-push-button /impulsing switch-key/ or by simultaneously pressing of two push-buttons "START" /or "Wł"/.

At the beginning reduce by means of hand wheel Cat.No16-11 the packing machine working speed near minimum and, in case of need, lubricate additionally the machine / during the idle run the greas. distribution is better/. Then increase gradually the machine speed till the standard working speed is reached.

Note: During initial 4 weeks of work, for better running-in the machine, the working speed should not exceed 60 cycles in minute.

9. Installing of packing material band and setting up the paper unit

9.1. Initial activities before installing the packing material

Shift the roller lifts Cat.No 16/5-20 and 16/4-7 to the revolving table. Lift the yoke of packing material brake Cat.No16/5-9 and catch it in the top position in the latch. Switch on the packing material sensor. Put the axle Cat.No 16/5-1 into packing material reel and mount in the bearings on the side plates in such a way, that the unreeling of packing material takes place from below. Set the reel in the centre of the axle. Lower the brake yoke Cat.No16/5-9. Set the side pins of the brake Cat.No16/5-10 1mm away from the roller. The moveable knife Cat.No16/9-2 set in

down position.

9.2. Packing material guidance unit - /Fig.1/

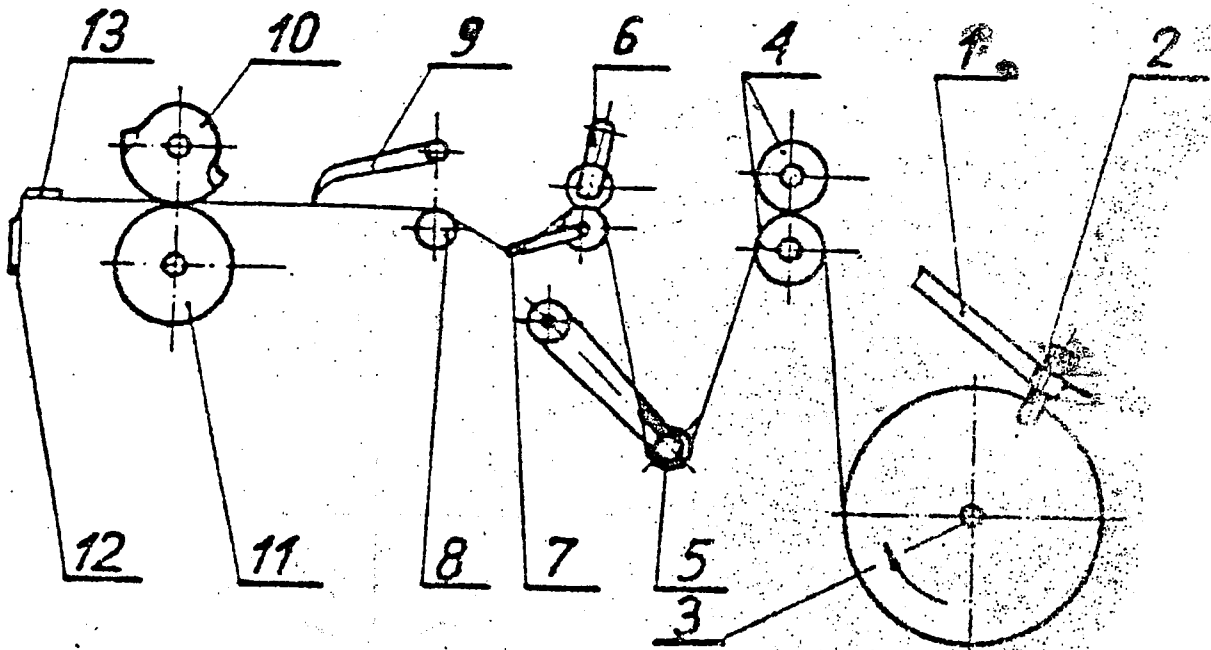

Fig.1

Unreel the packing material from below and put it between the feeding rollers /4/, under the rocker roller /5/, then between constant mandrels and brake rollers /6/, under the bow /7/, on the guide /8/ and guide table, through the date stamp to the transport rollers /10 and 11/. Pull the packing material so far, that the finger of mechanical centring device /9/ falls into second hole /when the holes not occur, pull the paper a little behind the cut-off knives 12 and 13/. Then stretch the band by turning "back" the packing material reel /3/, till the moment, when the rocker roller /5/ draws up more or less in the middle position. Lower the brake yoke /1/ and set the roller /3/ simmetrically between the pins /2/. The stretching force of the the bow /7/ can be adjusted by shifting the weights.

9.3. Setting of mechanical centring unit

The finger of the mechanical centring unit Cat.No 16/8-4 should be set on the transverse pin Cat.No16/8-2 so, that it hits the

the middle of the paper width in the axle of perforation holes. In the longitudinal direction, on the guide Cat.No16/8-3, the finger should be set so, that the band cut-off along its length takes place across the middle of the perforation hole. Set the length of band pulled by transport rollers /item 10 and 11 -Fig.1 so, that the perforation hole in the band of parchment paper is pulled ca 2-4 mm behind the finger end - item 9. When packing paper with plastics overlayer is used, it should be pulled 6-8 mm behind the finger. After pulling the band forward, the upper transport roller - item 10, slackens the band / when the part of roller with reduced radius passes by/ and then the bow -item 7, by its weight is pulling it back, till the finger falls into perforation hole in the band. After this operation the band is cut off. If the bow -item 7, pulls the band not enough, its lower stop should be reset down.

The mechanical centering unit is switched off /removed from the transverse guide/, when packing material with continuous overprint is used.

9.4. Switching on mechanical band feeding

see page for description

9.5. Setting of the date stamp

Turn the hand wheel of the packing machine drive until the lever of date stamp drive stops in the highest position. By means of enclosed pin turn the particular ring so, that required date occurs in the line marked by red arrows.

Depending on the packing material width, set properly the date stamp on the transverse guide -Cat.No16/11-5. Setting the date stamp in the middle of package length is carried out by shifting the base Cat.No16/11-5 along the oval hole in the side wall of

the paper unit.

9.6. Setting of the limit switch for paper lack signalling and of the paper sensor

After using up all the packing material band /or its break/, the roller Cat.No16/5-30 falls down and the lever Cat.No16/5-28 by the plate Cat.No16/5-33 must act on the limit switch Cat.No16/5-4. It causes switching off the packing machine run. The paper feeding sensor Cat.No16/10 in its down position should be depressed by ca 1 mm.

9.7. Removing of the band

The packing material band can be removed after execution of the same operations, like for installing the band /chapter 9.1/. Additionally the paper brake roll - item 6 on Fig.1 must be lifted over the ball latch. The finger of the centring device must be also lifted.

9.8. Characteristics and requirements regarding the packing material

see Enclosure No 1

10. Perturbations in the paper unit working

10.1. Cutting off the paper outside the middle of perforation hole - the register finger does not come into hole

Check the length of paper pulled by transport rollers and adjust the finger setting - according to chapter 9.3. When the adjustment gives no result, the paper perforation is incorrect.

Complain of this to the manufacturer of packing material band.

10.2. The overprint is not located in centre of the package surface

If the band and the paper cut off unit are set correct, and nevertheless the overprint is not located in the centre of the

package, it means, that overprint on the packing material is printed wrong. When the overprint deviation from the middle position on the width is more than 2mm, complain of this to the supplier. When the deviation is less than 2mm, it can be corrected by reset of guide pins of the packing material reel Cat.No 16/5-10, by shifting the mechanical centring unit Cat.No16/8-4 and the packing material guidance Cat.No19/1-1 and : When the overprint is shifted in direction of band motion, reset forward or backward the finger of mechanical centring unit. The shifting will be then inconcentric in relation to the band perforation hole.

10.3. Incorrect cutting of the packing material

Upper or lower knife is blunt. Disassemble the knives and sharper - see chapter 20.

Note:1. The tension of springs Cat.No16/9-10 must not be increased in order to improve the blunt knife action.

2. The upper knife has two cut edges. After dulling of one edge, knife can be turned by 180° and mounted according to chapter 20.

10.4. Incorrect supply of packing material to the revolving table

No action of the scraper Cat.No19/1-9 : Correct the scraper position and set it ca 2mm over the top edge of the package, or correct the packing material guidance. When the band moves unsymmetrically, the package formed in the forming head is at one side higher.

Crushed overlaps : The pressure rollers Cat.No19/1-7 are pressed down to much, or are used. By turning right 4 stop bolts the pressure rollers can be shifted maximum 0,5mm away from the forming plunger. Replace the used rollers.

11. Assembly of feeding worms - version „S“

When mounting the worms in the worm tray -Fig.13, comply with following rules:

- assemble the worms according to its directions /laevo-rotary worm on the left side and vice versa/. Check, if the marks "1" and "2", stamped on the worm ball pivot correspond to marks on the back wall of worm tray.
- put the worm ends with pins into sleeves Cat.No04-13 in the batcher body Cat.No04-10.
- close the worn drive box Cat.No13-4. Be sure, that the transverse pins of ball pivots are introduced into seats of the worm drive gears.
- turn the swing pin Cat.No13-8 into groove in drive body and turn off the grip Cat.No13-9.
- check, if the change gears Cat.No13/1-13 and-14, are selected properly for the packed product and cake format - according to table in chapter 18.
- put the lever bar Cat.No13-21 into position "I" for switching on the worm drive.

12. Packing start, troubles and adjustments

12.1. Preparation of packing machine for packing

Just before packing flush with cold water the tray and the worms / only when butter is packed/. Remove from the tray all the foreign matters: brushes, paddles etc. Check, if the filling mouthpiece and damper are fixed firmly.

The mark on the toothed ring of batching cylinder must correspond to marking on the rack-Cat.No7/4-6 / see chapter 14/

Check, if the cutoff -Cat.No19/2-1 works correctly, it means, if it moves without touching the down mouthpiece edge, but the

gap is so small, as possible. The cutoff must not be bended and must sinmetrically go into end position on the mouthpiece sides / a little wider, than inside mouthpiece sides/. When run-out on one side occurs, it can be corrected by adjustment of connector length - Cat.No19/2-3. The length of the cutoff way can be adjusted by changing the setting of pin Cat.No07/1-7 on the oval hole in the lever Cat.No7/1-6.

Arrange the change gears in the worm feeder according to the "Table of change gears" - chapter 18.

Fill the tray with product according to chapter 14.

Check, if all security devices are switched on according to chapter 8. If not, the motor can not be switched on.

Switch on the packing material feeding according to chapter 9.4. Switch on the motor by pressing two push-buttons on the control desk.-

Produce some empty packages and test the correctness of package forming.

Set the switching lever of worm drive Cat.No13-21 in position "I". The worms transport now the packed product to the front space of the tray under the compensation plunger. When very soft products should be packed, it is recommended to shift initially packed product under the compensation plunger by means of hand crank. Do not forget to switch off the drive by setting the lever Cat.No13-21 in position "C". Switch on batching by setting the lever Cat.No01/2-2 in position "I".

Check the package weight and correct by exact adjustment by means of hand wheel Cat.No16/7-2 /one turn of hand wheel results in the correction of 2,5 - 3g - depending on product's specific gravity/. It is recommended to weight simultaneously four packa-

ges, check the average weight and then carry out exact adjustment.

12.2. Perturbations during package filling

The most often reason of errors in package filling is incorrect adjustment of the revolving table pocket Cat.No19-7 or 20-7.

It results in manufacturing of faulty packages and cakes with incorrect form. The filling mouthpiece Cat.No19-6 is set during the assembly by means of connector Cat.No01-70, jointed with slider Cat.No04-19 at the distance 8mm from the bottom Cat.No19-7 while the mouthpiece and bottom are in their lowest position / the bottom does not repose on the pusher and the guide, but lies on the ring Cat.No20-3/.

Using the handwheel Cat.No01-39 adjust the lifting of the bottom so, that the correct package filling takes place.

On the Fig.2 the correct filling, before beginning of the final package closing is shown. The packed product should protrude ca 1mm over the top edge of revolving table.

On the Fig.3 the incorrect filling is shown. The product narrows in the top. The reason: to big distance between the mouthpiece and the pocket bottom in the lowest position. To remove the perturbation lift up the pocket bottom - see chapter 6 "Service elements". On the Fig.4 the opposite error is shown - the filled product shapes the trough. Lower the pocket bottom - see chapter 6 "Service elements".

The perturbations during package filling may be caused by irregular filling of the worm tray. The tray should be periodically filled uniformly with small batches. The formed roll should be kept on the height of the top tray edge - see Fig.5.

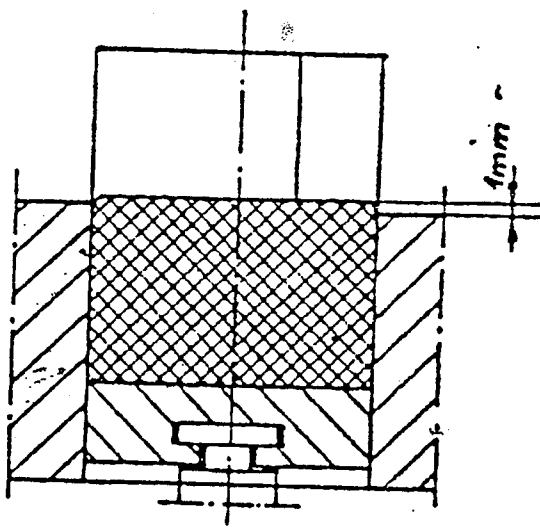

Rys. 2
Fig. 2

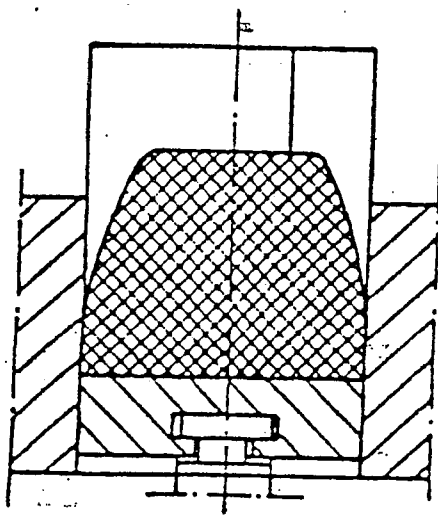

Rys. 3
Fig. 3

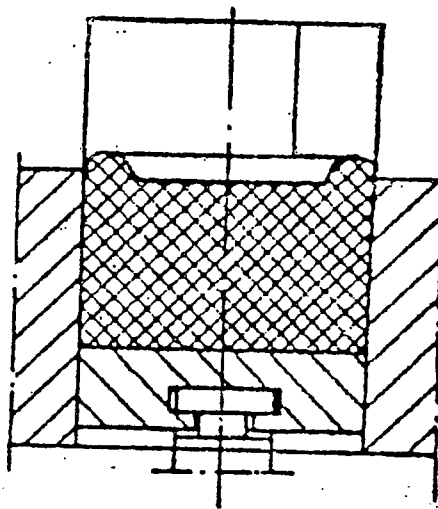

Rys. 4
Fig. 4

Keep the roll on the same height

Feeding place for butter
at temperature 12° C - 16° C

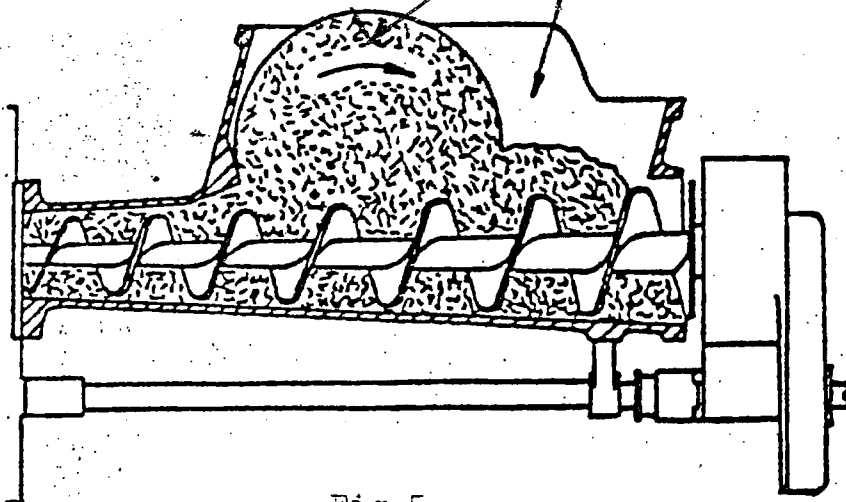

Fig.5

9.4 Switching on the mechanical band feeding

After execution of above mentioned operations switch on the pulling and the feeding of band by setting the lever of roller lifters Cat.No16/5-20 and 16/4-7 in the direction of paper reel. By turning the hand wheel of packing machine drive, test exactly the paper run, the package forming in the forming head and the supply to the revolving table pocket.

12.3. Back suction device - principle of operation and adjustment

Any kind of packed product is not fully deaerated and therefore is more or less compressible. Therefore during filling the package or when the feeding of packed product is cut, the product in package can connect again with product bar, coming out from the mouthpiece, as a result of product expansion.

The batching plunger Cat.No07-8 or 9, makes a small back motion after feeding stroke. Although this motion is very small, it prevents the product outflow from the mouthpiece.

The back suction can be adjusted as follows:

Loosen the lock nut and reset the adjusting screw Cat.No01/6-15.

When the distance between the lock plate Cat.No01/6-6 and two

guides Cat.No01/6-7 and 8, is zero, the back suction is most active. When the distance increases, the suction action decreases. Most quickly the required stroke can be adjusted by changing the back suction stroke by steps of ca. 1mm. The back suction stroke must be kept as small as possible.

The suction stroke change causes the change of the packed product weight. Therefore, after adjustment of back suction stroke correct the package weight.

12.4. Adjustment of cutting bow cam

The cam Cat.No07/1-11, which drives the cutoff Cat.No19/2 is adjustable and depending on the packed product features should be set in such position, that package pulling not occurs.

When very soft products are packed, the cam should be set so, that the product's cutting off starts together with start of the back suction /it means, at beginning of the back motion of batching plunger/.

When more dense products are packed, the cam should be set so, that product's cutting off starts at the end of back suction.

Note: When the cam is reset in direction of its rotation - the cutting off takes place earlier, and vice versa.

12.5. Operating the closing unit

Both hinge wrappers Cat.No19-11 and 12 /or 20-11 and 12/ must move easily on their levers and hinges. The distance between the wrappers and the table surface is set by the manufacturer /it should be 0,2-0,5 mm/ and needs no adjustment. The pulling spring of the wrapper must be efficient. The lack of spring may cause the damage of wrapper and working troubles.

All the wrappers should be handled with care to avoid their deformations or defects.

13. Operating the batching cylinder, the batching plunger and the compensation plunger

The batching cylinder Cat.No07-10 /or 11/, the batching plunger Cat.No07-8/or 9, and the compensation plunger Cat.No04-4 are most important, and on the other hand, the most sensitive packing machine parts. Therefore must be handled with special care.

The surfaces of cylinder and of both plungers in any case must not be damaged. If any defect is stated, the damaged place must be before assembly carefully polished with the finest abrasive paper. It refers also to cylinder bearing in the batcher body. For putting the cylinder aside, two special supports, located in the worm tray are provided. In the form T and D these supports are delivered separately - Fig.23.

Before assembly of batching cylinder grease always thorough its outside surface-and its bearing in the batcher body.

For greasing of batching cylinder and plungers, use the packed fat /butter, lard, margarine/, whey butter or tasteless vaseline.

When fatless products are packed, use of following grease for cocks is recommended: UVN-PLB "dampfbar", made by company Theodor Klüber, München 25, Germany.

Care should be exercised, when cleaning the plungers Cat.No07-9 / or 8/ and 04-4. Possible scratches on the plunger surface and on its bearings in the body polish carefully with abrasive paper.

14. Setting up for packing butter

Just before packing butter wash using hot water the worm tray and worms Cat.No13-3, 13-1, 13-2, the cutoff Cat.No19/01 and the lower, external mouthpiece edge. Then clean these parts with brush, using 10% solution of lye and hot water or solution of hot water and wash medium for kitchen utensils, without

abrasive additions.

Left such prepared parts for 10 minutes for drying, and then wash them with cold water in order to lower their temperature below the temperature of packed product.

- Notes: 1. Avoid touching with hands the prepared parts
2. Avoid passing of hot solution into the batching cylinder bearing
3. Following elements must not be washed with hot solution:
- batcher body - Cat.No04-10
 - batching cylinder - Cat.No07-11 or 07-10
 - batching plunger - Cat.No07-09 or 07-08
 - compensation plunger - Cat.No04-4
 - elbow - Cat.No04-21
 - slider - Cat.No04-19 or 04-20
 - inner mouthpiece surface - Cat.No19-6
- These parts should be washed with hot water without wash medium addition
4. The above described preparation of worms by means of hot washing medium is not required when packing cottage cheese, lard and similar products.

The elements should be mounted in reverse order like described in chapter 16, with complete regard to recommendations given in chapter 13.

The mark on the toothed ring of cylinder must agree with mark on the toothed segment Cat.No07/4-6. In other case the weight errors of packed product will appear, or heavy packing machine damage may happen.

When mounting the slider plate Cat.No04-19 /or 20/, be sure, that the nut is firmly tighten in the connector Cat.No01-74 and its lip comes into plate groove. Grease the batching plunger

Cat.No07-9 /or 8/, and fasten it in the plunger rod guide. Grease the compensation plunger Cat.No04-4, put it into batcher body and fasten it.

15. Packing of cottage cheese

To avoid the second machine washing during one packing cycle, it is recommended to pack cottage cheese in combination with packing of butter. When only cottage cheese is packed, it is recommended to start with more fatty sorts.

The big batcher hole Cat.No04-10 and outer surfaces of batching cylinder should be greased with tasteless fat. The tray should be filled till the level ca 200 mm below the upper edge. The highest worm rotation speed should be used, it means, that the change gears Cat.No13/1-18, 29 teeth, and 13/1-19, 65 teeth, must be mounted so , that the driving gear has 65 teegh, and the driven - 29 teeth.

The cheese should be packed into 250g cakes only, using for filling the small mouthpiece and cut off knife-Cat.No20-6 and 20/2-1.

When the packing machine is delivered for big format /cake 250g/ only, for packing of cottage cheese additionally the above mentioned mouthpiece, cut off knife and change gears must be ordered.

16. Cleaning

After each working period the packing machine parts, which contact the packed product should be cleaned. In no case use for this operation soda or caustic soda, acids, steel brush or other objects, which may cause scratching of machine elements. The cleaning must absolutely be carried out during the machine standstill. Before cleaning, the machine parts must be disassem-

bled as follows:

- a/ turn back the feeding worms /by means of hand crank/ and remove the rest of packed product
- b/ open the feeding worms drive by turning back the clamp grip / after removing the hand crank/ and take out the feeding worms Cat.No13-1 and 2
- c/ unscrew two nuts Cat.No04-25 and remove the compensation plunger Cat.No04-4
- d/ remove the batching cylinder shield Cat.No07-12
- e/ unscrew the plunger rod nut /wrench size 19/ - Cat.No07/3-4 or 07/2-3/ and remove the batching plunger Cat.No07-9/8 from the batching cylinder Cat.No27-11/ -10
- f/ set the switch off lever of batching cylinder Cat.No01/2-2 at "0". When the pawl Cat.No07/4-2 is slacken on the segment driver Cat.No07/4-1 /in case of need pull it by turning the hand wheel/, pull the mandrel Cat.No01-31/02-2 out and turn the batching cylinder at the knurled surface till the moment when the teeth completely get off the rack Cat.No07/4-6.
Remove the batching cylinder
- g/ lift the hinged shield Cat.No21-4. By means of hand wheel shift the filling elbow Cat.No04-21 to its highest position. Loosen the strip nuts Cat.No04-22 and remove the mouthpiece Cat.No19-5. Loosen the screws and remove the axle Cat.No04-2. Remove the cutoff lever complete Cat.No19-5.
Note: The cutoff lever is very fragile element and should be handled with care to avoid bending of the cutoff
- h/ unscrew the nut Cat.No04-18 /wrench size 18/and disconnect the support Cat.No01-74 from the slider complete Cat.No04-19
Put it back on the lever stop Cat.No01-58. Pull out the

slider complete Cat.No04-19 up.

Wash carefully the batching device and all disassembled parts with pure water and dry them. Do not use any wash medium.

Note: When washing plastics parts, the water temperature must not be higher than 60°C. Keep plastics parts in this temperatur no longer than 2 minutes

When cleaning the machine, prevent passing the water to steel parts. It may cause its rusting. Do not sprinkle the packing using hose. When it is not possible to secure adjoining parts against water contact, e.g. by covering with foil, clean them carefully, dry and grease. It refers also to all parts with galvanic coating and polished parts made from light metals.

All they need to be greased. It prevents efficiently corrosion in moist environment.

17. Reconstruction of packing machine for another format

/ not applied for version for format 95 x 63,5 x 44 /

All parts for format 250g are marked with figure I

All parts for format 125g are marked with figure II

17.1. Format change from 100 x 75 mm to 75 x 50 mm

/ from 250g to 125g /

- a/ press the red push-button STOP on the control desk
- b/ move up the front shield Cat.No21-4
- c/ switch off the batcher by setting the lever Cat.No01/2-2 at "0"
- d/ switch off the worm drive by setting the lever Cat.No13-20 at "0"
- e/ set the punch Cat.No16/1-12 in the highest position
- f/ remove the roller Cat.No16/3-7 and 8
- g/ loosen the nuts /wrench size 17/ and remove the preliminary bender Cat.No19-14

- h/ unscrew the internal wrenching bolt / insert wrench 6/ and remove the plunger complete Cat.No19-3
- i/ unscrew two bolts Cat.No16-19 and remove the forming head Cat.No19-1
- j/ unscrew the nut /wrench size 14/ and remove the mouthpiece Cat.No19-6
- k/ remove the axle Cat.No04-24 and cutoff lever Cat.No19-5
- l/ set the closing device in open position. Unscrew the bolt in the upper part of closing device and turn the plate with oval hole Cat.No02-5 by 90° . The levers are locked now. Tighten the screw. Take off two connectors Cat.No01-13 from upper ball pins. Unscrew the bolt, take off washers with recess and remove the closing device.
- m/ take off the scraper strip Cat.No19-13
- n/ unscrew the cross holder Cat.No01-1 and remove the pressure plate Cat.No 19-2
- o/ pull the ball knob located under the table and remove bottoms of the revolving table pockets - between batching stand and wrapping stand
- p/ loosen the lock and take off the revolving table inserts
/only for the table form with round pockets/
- r/ disassemble the cake overturn unit Cat.No19-9
- s/ disassemble the cake ejector Cat.No19-4
- t/ assemble all the parts marked with figure II in reverse order as described in points f-r. When placing the inserts Cat.No 20-17 and the bottoms Cat.No20-7, pay attention to correct numeration and good setting of the protections
- u/ reset the paper feeding sensor Cat.No16/10-1
- v/ set the mechanical centring device Cat.No16/8 according to

chapter 9.3 and 10.1

w/ reset the date stamp

x/ reset the transport roller Cat.No16/4-10 by unscrewing the bolt /wrench size 14/ and setting the mark on figure II

y/ unscrew the locking handle Cat.No16/13-11 and reset the ejector drive on figure II

z/ change the packing material reel and reset the guide pins

z1- remove the shield Cat.No21-7 and reset the lever Cat.No01/6.

Loosen the key Cat.No01/6-3, turn the knurled rod Cat.No

01/1-3, till the slider Cat.No01/1-9 comes into lever's

groove. By means of the arm Cat.No01/1-5 shift the lever

to required position, inserting the roller into groove

of the oposite cam Cat.No01-67.Tighten the key Cat.No01/6-3.

z2- change the change gears according to chapter 18 "Change of the worm rotation speed"

17.2. Format change from 75 x 50 to 100 x 75 / from 125g to 250g/

When changing the format from 75 x 50 to 100 x 75, follow the instructions given in chapter 17.1.

The difference consists in assembling parts marked with figure II instead of parts marked with figure I.

18. Change of the worm rotation speed - version „S“

When changing the size of packed cakes, it is necessary to reduce or increase the quantity of product feeded by worm.To this end, open the cover Cat.No13/1-4 and change properly gears Cat.No13/1-13 and 14, or 20-1 and 20, according to following table of change gears.The diagram of drive gear box is shown on Fig.6

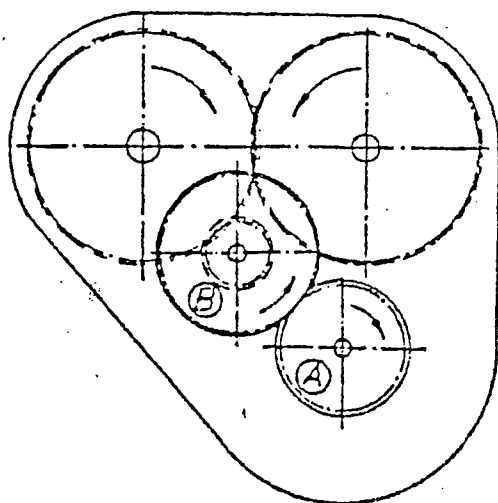

Fig.6

Change gear table

Change gear A /driving gear/	Change gear B /driven gear/	Range of packed cakes weight	Worm rotation for one cycle	Wheel colour
z=29	z=65	90-150g	standard 0,13	yellow
z=44	z=50	150-260g	standard 0,26	red
z=50	z=44	150-260g	for dense products 0,33	red
z=65	z=29	90-260g	for cottage cheese 0,66	yellow

It is recommended to use standard gear sets. When significant weight differences occur, caused by especially soft or dense product, mount the accelerating gear sets.

19. Replacement of the conveyor band

Unscrew the stretching nut Cat.No08-14 and loosen the transport band. Remove the shield Cat.No01/3-2 and deflect the carrying away conveyor by 90° in direction of packing material band.

In this connection following parts must be disassembled:

- cover Cat.No08/-14/5
- joint head Cat.No03-10
- spring Cat.No03-9
- side wall Cat.No01/3-13 with the lever Cat.No01/3-10/63-19
and connector Cat.No01/3-6

Take off the band from the driving roller aside over the table.

The assembly of new band is carried out in reverse order. Be sure, that the band is located between stretching rollers Cat.No08-14/4.

Pay attention to the direction of band movement.

After assembly the band should be stretched 15 to 20 mm at least.

To this end loosen the nut /wrench size 24/, stretch the band by means of stretching rollers /wrench size 30/ and tighten the nut.

On the front side of supports Cat.No08-11 and 12, on the conveyor's end, two bolts for band adjustment are provided. If needed, turn the bolts separately, till the band runs evenly in the middle of roller's width.

20. Replacement of knives for cutting the packing material

20.1. Disassembly of lower knife

- a/ set the bending punch in its highest position
- b/ unscrew two bolts Cat.No16-19 and remove the forming head
Cat.No19-1 /or 20-1 and 18-1/
- c/ remove two pull springs Cat.No16/9-11
- d/ unscrew the bolts of knife fixing
- e/ take off the knife

20.2. Disassembly of upper knife

- a/ unscrew two nuts of the guide Cat.No16/9-7
- b/ remove the guide
- c/ take off the knife

20.3. Sharpening of knives

The sharpening of knives should be carried out by machinery. When sharpening, preserve the angles given on the Fig.7.

Note: The upper knife has two blade edges.

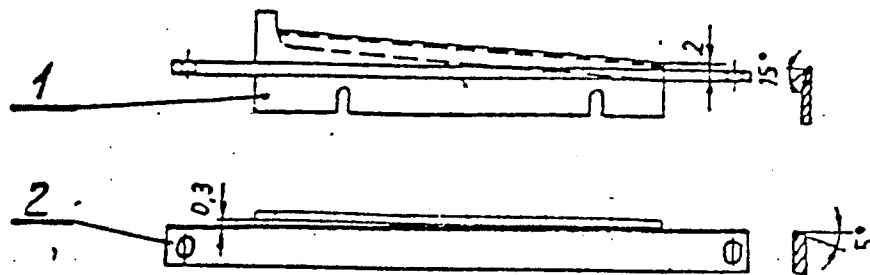

Fig.7

20.4. Assembly of upper knife

Put the upper knife on the bolts - it must adhere to vertical guide protrusion Cat.No16/9-5. Put on the upper guide Cat.No16/9-7 and fasten both parts by means of nuts.

20.5. Assembly of lower knife

The assembly of lower knife should be carried out in reverse order to instructions given in chapter 20.1 "Disassembly of lower knife". Be sure, that cutting edges after cut off move overlap ca 2 mm - see Fig.7. Adjustment can be made by shifting aside the set block Cat.No16/9-6. Tighten all the nuts. The knife holder should turn easily around its axle /pay attention to greasing/. The correct knife position is shown on Fig.7.

21. Replacement of lubrication hose

Remove screws fixing the spoiled hose /wrench size 14/. Its union piece put on the new hose with small bore turned forward. Shift the cutting ring on the hose with its thick side turned forward. Press the brass insert into the hose. Put on the connector pipe and tighten the parts firmly. By turning tight the cutting ring is pressed with its thin end into the hose and therefor its setting is firm.

22. Operating the variable-speed belt transmission - Cat.NoC1/8-7

- a/ do not adjust the transmission during the standstill
- b/ the support and the motor shift adjustment should be set so, that the belt does not run outside the disk edge or, otherwise, is not pulled to the diameter, which is too small.
- c/ when assembling, the marks 0-0 and 1-1 on splined hub and on the disk must agree. The marks 0 and 1 are located on the front sides of the hub, over the grease groove.

23. Guidelines regarding service, inspections and repairs of the machine

23.1 General remarks

The packing machine should be kept in state of constant technical efficiency by suitably arranged system of service, technical inspections and repairs, which must be absolutely followed by the direct servicing personnel and the maintenance service.

The packing machine must be operated and maintained by qualified personnel only, which is reliable and ensures good fulfilment of its duties. Please, assigne one person with some technical skills as responsible for the machine and the second one, which must also be good acquainted with the machine, as its deputy. When the machine is putted into operation by manufacturer's fitters, the user should attend to thorough knowledge the machine structure and operating by servicing and maintenance personnel. The engineering supervision of user's company should in person check, best during formal acceptance, the proper machine work, and first of all, if the servicing personnel is good acquainted with machine service, greasing, washing, setting on another format etc. The machine user must ensure full compliance with contents of this operation manual, delivered by the machine manufacturer together with the machine.

If needed, proper instructions for additional service activities should be worked out.

23.2. Operating the machine

The duties of servicing personnel are following:

- putting on the packing material
- packing machine set-up
- inspection of the packed product quantity in the worm tray /or in feeding funnel/
- adjustments related to packing process
- taking the ready packages from the machine
- care about proper package manufacturing
- inspection of packing machine working - the work of particular mechanisms must be continuously supervised. If any irregularity is stated, machine must be stopped and fault eliminated
- keeping the machine in cleanness
- routine lubrication of the packing machine /according to chapter 7/
- cleaning the machine after work end

23.3. Technical inspection

It is recommended, to carry out after every 100-150 working hours /or once in a month at least/ the complete packing machine inspection. It should be done by the maintenance technician.

Before this inspection the machine must be cleaned from dust, old grease, coming out from the bearings in particular mechanisms, and from other impurities.

During the inspection check, if:

- a/ all the rollers co-operating with cams rotate easily on their pins /when the rollers rotate hard, it causes quick cam wear/
- b/ the pins are firmly set on the levers

- c/ all screw joints are tight
- d/ the cone pin joints are not loose
- e/ the levers move easily on their bearings
- f/ any points are not excessively worn out

After inspection lubricate the packing machine thoroughly, according to lubrication instructions given in chapter 7. Then fix the shields.

23.4. Adjustment guidelines for possible disassembly and assembly of the packing machine

When disassemble the packing machine, turn the hand wheel, till the marks on following shafts come into top vertical position:

- Shaft Cat.No16/4-8
- Shaft Cat.No16/4-12
- Shaft Cat.No16/3-2
- Cam shafts Cat.No01-22

The assembly should be carried out in the same position of shafts. If these marks on above mentioned shafts are lacking, they can be made before disassembly by fitter. Before marking, the packing machine should be set by turning the hand wheel at the moment of beginning of revolving table standstill. Mark by punching the vertical line at the top side.

23.5. Repairs

According to general principles of machine repairs, for extension of packing machine operation use following repairs should be scheduled:

- running repair
- routine repair
- general overhaul

The running repairs should be carried out for elimination of defects arising during machine use and noticed during technical

inspections, and for replacement of used parts. The running repair should be carried out every 2000 machine working hours.

The frequency of routine repairs and of general overhauls should be fixed according to obligatory branch regulations and depending on the use grad and own experience in using of this kind of machines. The decision about machine repair should be taken by the board of user's company.

It is recommended to commission the specialistic company to carry out the machine repair.

When replacement of machine parts is needed, use only the original spare parts.

23.6. Specification of spare parts

The spare parts should be specified on the ground of enclosed "Spare parts catalogue" and on the ground of this operating manual. In order to determine the spare part number, find on the enclosed drawing of particular assembly or sub-assembly, and comparing it with machine design, the item specifying this part, and then read in the table referring to this drawing the catalogue number and the part name. The catalogue number consists of first element /before the dash/, specifying the drawing number in spare parts catalogue e.g. 01-, 07/2-, 16/10- etc. and of the number /behind the dash/, specifying the drawing item e.g. -2, -35 etc. For full definition of spare part it is enough to give the catalogue number and the part name e.g.

01/1-4 - Lever

16-19 - Bolt, complete etc.

In the column "Notes" additional informations regarding numeration of sub-assembly drawings are given. If no separate drawings for given unit are provided /unit 18, 19, 20, 21 and 24.

in this column the number of drawing, on which this part can be found, is shown.

For items meaning the small sub-assemblies the particular details are not separately appointed, e.g. lever sleeves, connector details. In this case the part should be specified by its description in the unit, and when several similar parts occur, its location or size should be given e.g.

- lever sleeve - catalogue number 01-18 - 2pcs
- lower joint M18x1,5, left in the connector complete,
catalogue number 01-57 - 1pc

24. Work safety rules

When operating the packing machine, general work safety regulations for users of this kind of machines must be observed, and in particular:

- removing of shields during machine work is prohibited
- packing machine adjustment during its work /except changing the ratio of variable-speed belt transmission/ and when power supply is switched on, is prohibited. All regulations should be made during the machine standstill, or when the machine is driven by hand
- leaving of any objects on the packing machine during its work is prohibited
- installing of packing material during packing machine work is prohibited
- bringing the hands or other body parts near the uncovered moving machine parts is prohibited
- pay attention to the packing machine work. If any irregularity occurs, switch the machine off and contact the maintenance technician

- during the adjustment, the machine must be switched on, if needed, only by means of "Ruch chwilowy"-push-button /impulsir switch/
- the machine work start is possible after pushing of two push-buttons "Start" /"Wł"/. These push-buttons are located on the control desk so, that for switching on both hands must be used
- the shield interlocks / front hinge shield, cover of the worm drive gear/ on the machine must always be efficient

25. Work movement diagram

Number of cam drawing	Benhil No	Movement phase	Setting from ^c	to ^o
XPG 40				
-01-00-49	8380-002-060	Revolving table stand-still	0	210
-01-00-62	8380-011-300	Eatching cylinder rotation	0	115
-01-00-76 -01-00-78	8380-501-013 8380-501-023	Eatching plunger - batching stroke	75	145
-01-00-51	40B 113.5	Lifting the bottoms in the revolving table pocket	80	160
-16-21-03 /2 pcs/	8340-061-014	Paper cutting off and date punching	120	160
-07-06-04	8380-060-140	Batched product cutting off	150	180
-16-03-04	40E.756.3	Paper feeding by feeding rollers	180	270
-17-00-11	8380-120-091	Cake pusher- limit forward position	185	
-16-07-08	8380-052-121	Paper shifting through the transport rollers Ø90	205	Format
-01-19-14	8380-117-010	Overturning of packed cakes	230	350

-16-27-04	8380-056-020	Paper pusher-verti- cal motion up	240	280
-01-00-47	8380-056-010	Paper pusher- horizon- tal motion forward	250	360
-01-28-03	8320-017-052	Cake pressure	285	
-01-00-60	40G 117.3	Single motion of wrapper in cake direction	320	15
-16-02-01	8340-058-011	Initial paper bending /motion down/	325	5
-01-00-94	8340-500-023	Lowering of batching mouthpiece	330	75
-01-00-56	40G.79.2	Side wrappers movement in cake direction	340	55
-16-24-03	8380-059-011	Paper feeding sensor /contact point/	340	

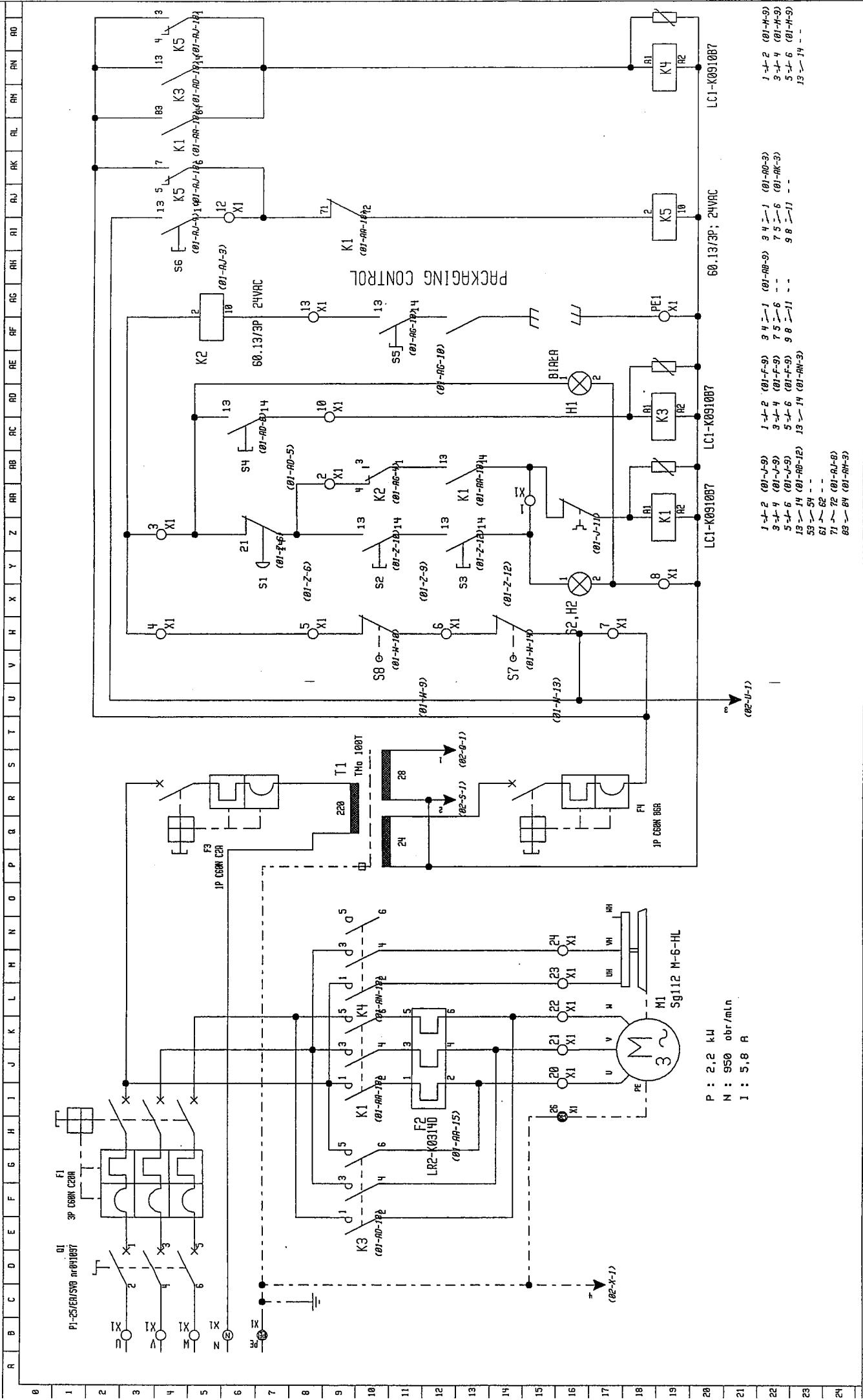

PACKAGING CONTROL

P : 2.2 kW
 N : 950 obr/mln
 I : 5.8 A

- 1-2 (01-1-9)
- 3-4 (01-1-9)
- 5-6 (01-1-9)
- 13-14 (01-1-9)
- 59-61
- 71-72
- 89-91
- 1-2 (01-1-9)
- 3-4 (01-1-9)
- 5-6 (01-1-9)
- 13-14 (01-1-9)
- 59-61
- 71-72
- 89-91
- 1-2 (01-1-9)
- 3-4 (01-1-9)
- 5-6 (01-1-9)
- 13-14 (01-1-9)
- 59-61
- 71-72
- 89-91

TREPKO AIS Kuldjussen 15-17 2630 Tooststrup, Denmark TEL. +45 43 99 22 44 FAX +45 43 99 01 12		CUSTOMER: MALAYSIA		ENGINEER: DATE 19-01-2006 12:36:31	Type: XPG-40		Prev.: Next.: 02	LAST PAGE: PAGE:
YEAR 2006		MACHINE no. 3644		ELECTRIC DIAGRAM		UNIT: 121-24-00-00		3
C:\DYSK\S\XPG-40\SCHEMATY\XPG-40.1.006V2\								01

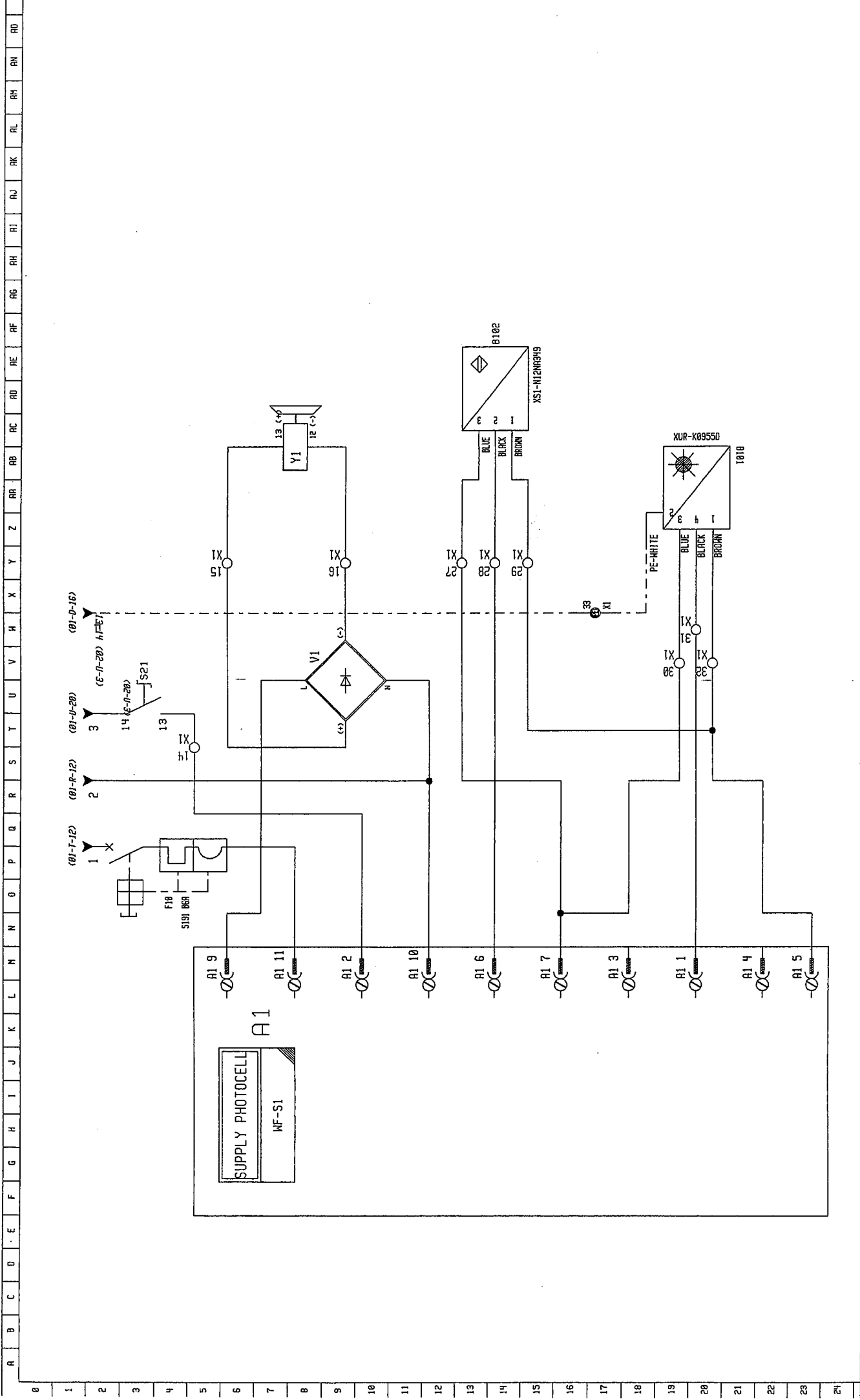

A	B	C	D	E	F	G	H	I	J	K	L	M	N	O	P	Q	R	S	T	U	V	W	X	Y	Z	AA	AB	AC	AD	AE	AF	AG	AH	AI	AJ	AK	AL	AM	AN	AO	AP	AQ	AR	AS	AT	AU	AV	AW	AX	AY	AZ	BA	BB	BC	BD	BE	BF	BG	BH	BI	BJ	BK	BL	BM	BN	BO	BP	BQ	BR	BS	BT	BU	BV	BW	BX	BY	BZ	CA	CB	CC	CD	CE	CF	CG	CH	CI	CJ	CK	CL	CM	CN	CO	CP	CQ	CR	CS	CT	CU	CV	CW	CX	CY	CZ	DA	DB	DC	DD	DE	DF	DG	DH	DI	DJ	DK	DL	DM	DN	DO	DP	DQ	DR	DS	DT	DU	DV	DW	DX	DY	DZ	EA	EB	EC	ED	EE	EF	EG	EH	EI	EJ	EK	EL	EM	EN	EO	EP	EQ	ER	ES	ET	EU	EV	EW	EX	EY	EZ	FA	FB	FC	FD	FE	FF	FG	FH	FI	FJ	FK	FL	FM	FN	FO	FP	FQ	FR	FS	FT	FU	FV	FW	FX	FY	FZ	GA	GB	GC	GD	GE	GF	GG	GH	GI	GJ	GK	GL	GM	GN	GO	GP	GQ	GR	GS	GT	GU	GV	GW	GX	GY	GZ	HA	HB	HC	HD	HE	HF	HG	HH	HI	HJ	HK	HL	HM	HN	HO	HP	HQ	HR	HS	HT	HU	HV	HW	HX	HY	HZ	IA	IB	IC	ID	IE	IF	IG	IH	II	IJ	IK	IL	IM	IN	IO	IP	IQ	IR	IS	IT	IU	IV	IW	IX	IY	IZ	JA	JB	JC	JD	JE	JF	JG	JH	JI	JJ	JK	JL	JM	JN	JO	JP	JQ	JR	JS	JT	JU	JV	JW	JX	JY	JZ	KA	KB	KC	KD	KE	KF	KG	KH	KI	KJ	KK	KL	KM	KN	KO	KP	KQ	KR	KS	KT	KU	KV	KW	KX	KY	KZ	LA	LB	LC	LD	LE	LF	LG	LH	LI	LJ	LK	LM	LN	LO	LP	LQ	LR	LS	LT	LU	LV	LW	LX	LY	LZ	MA	MB	MC	MD	ME	MF	MG	MH	MI	MJ	MK	ML	MN	MO	MP	MQ	MR	MS	MT	MU	MV	MW	MX	MY	MZ	NA	NB	NC	ND	NE	NF	NG	NH	NI	NJ	NK	NL	NM	NO	NP	NQ	NR	NS	NT	NU	NV	NW	NX	NY	NZ	OA	OB	OC	OD	OE	OF	OG	OH	OI	OJ	OK	OL	OM	ON	OO	OP	OQ	OR	OS	OT	OU	OV	OW	OX	OY	OZ	PA	PB	PC	PD	PE	PF	PG	PH	PI	PJ	PK	PL	PM	PN	PO	PP	PQ	PR	PS	PT	PU	PV	PW	PX	PY	PZ	QA	QB	QC	QD	QE	QF	QG	QH	QI	QJ	QK	QL	QM	QN	QO	QP	QQ	QR	QS	QT	QU	QV	QW	QX	QY	QZ	RA	RB	RC	RD	RE	RF	RG	RH	RI	RJ	RK	RL	RM	RN	RO	RP	RQ	RR	RS	RT	RU	RV	RW	RX	RY	RZ	SA	SB	SC	SD	SE	SF	SG	SH	SI	SJ	SK	SL	SM	SN	SO	SP	SQ	SR	SS	ST	SU	SV	SW	SX	SY	SZ	TA	TB	TC	TD	TE	TF	TG	TH	TI	TJ	TK	TL	TM	TN	TO	TP	TQ	TR	TS	TT	TU	TV	TW	TX	TY	TZ	UA	UB	UC	UD	UE	UF	UG	UH	UI	UJ	UK	UL	UM	UN	UO	UP	UQ	UR	US	UT	UU	UV	UW	UX	UY	UZ	VA	VB	VC	VD	VE	VF	VG	VH	VI	VJ	VK	VL	VM	VN	VO	VP	VQ	VR	VS	VT	VU	VV	VW	VX	VY	VZ	WA	WB	WC	WD	WE	WF	WG	WH	WI	WJ	WK	WL	WM	WN	WO	WP	WQ	WR	WS	WT	WU	WV	WW	WX	WY	WZ	XA	XB	XC	XD	XE	XF	XG	XH	XI	XJ	XK	XL	XM	XN	XO	XP	XQ	XR	XS	XT	XU	XV	XW	XX	XY	XZ	YA	YB	YC	YD	YE	YF	YG	YH	YI	YJ	YK	YL	YM	YN	YO	YP	YQ	YR	YS	YT	YU	YV	YW	YX	YY	YZ	ZA	ZB	ZC	ZD	ZE	ZF	ZG	ZH	ZI	ZJ	ZK	ZL	ZM	ZN	ZO	ZP	ZQ	ZR	ZS	ZT	ZU	ZV	ZW	ZX	ZY	ZZ	PREV.: 01	LAST PAGE:	3
																																																																																																																																																																																																																																																																																																																																																																																																																																																																																																																																																																																																																																																																																																																											Next.:	PAGE:	02
CUSTOMER: MALAYSIA		ENGINEER:	Type: XPG-40		C: \DYSK 5\XPG-40\SCHEMATY\XPG-40\1006V2\																																																																																																																																																																																																																																																																																																																																																																																																																																																																																																																																																																																																																																																																																																																								
DATE 19-01-2006		12:56:32	UNIT: 121-16-51-00																																																																																																																																																																																																																																																																																																																																																																																																																																																																																																																																																																																																																																																																																																																										
MACHINE no. 3644		YEAR 2006	PHOTOCELL																																																																																																																																																																																																																																																																																																																																																																																																																																																																																																																																																																																																																																																																																																																										
TREPKO A/S Kuldjssøen 15-17 2630 Toøstrup, Denmark TEL. +45 43 99 22 44 FAX +45 43 99 01 12																																																																																																																																																																																																																																																																																																																																																																																																																																																																																																																																																																																																																																																																																																																													



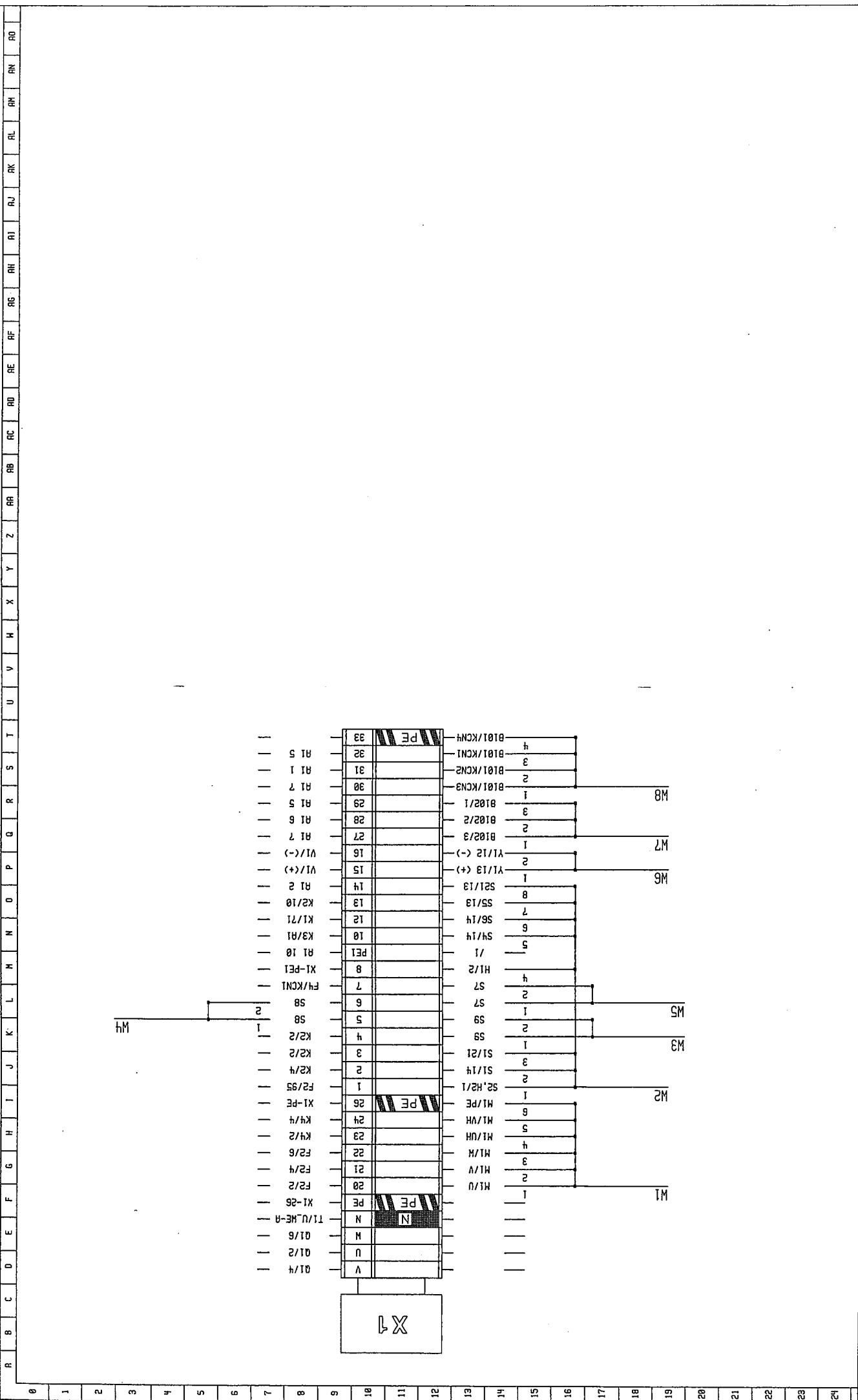

R B C D E F G H I J K L M N O P Q R S T U V W X Y Z AA AB AC AD AE AF AG AH AI AJ AK AL AM AN AO

TREPKO A/S
Kuldyssen 15-17
2630 Toastrup, Denmark
TEL. +45 43 99 22 44 FAX +45 43 99 01 12

CUSTOMER: MALAYSIA

ENGINEER: _____
DATE 19-01-2006 12:36:31

YEAR 2006

MACHINE no. 3644

Type: **XPG-40**

UNIT: X1

Prev.: _____

Next.: _____

C:\DYSK\S1XPG-40\SCHEMATY\XPG-40\1006V2\

LAST PAGE: 3

PAGE: 05

UNIT: X1

PHOTO CELL PAPER ALIGNMENT

On clamps #1 and #2 goes voltage from 22 VAC converter (transformer)

On clamps #3 and #4 goes voltage 8 VAC.

Clamps #5 and #6 should go to pins #C4 and #C5 and to them connected is electric valve of pneumatic servo-motor.

Clamp #9 goes to pin B2 - induction sensor power (24VDC)

Clamp #11 goes to pin B4 - signal from sensor

Clamp #12 goes to pin B5 - mass (0VDC) (mass being (-))

Clamp #13 goes to pin A5 - mass

Clamp #14 goes to pin A4 - photo sensor signal

Clamp #15 goes to pin A3 - sensor power (24VDC)

In order to check the system you need to disconnect wires from clamps #11 and #14. Prepare 2pcs of bistable switches (like the ones for switching lights on and off) and connect both of them from one end to 24V (clamp#9 or #15) and the other ends to clamps #11 and #14.

Position the switches so that they are not in short-circuit - green leds FOTO and SYGNAL Z are not illuminating

Switching on the switch connected to clamp #11 will light led SYGNAL Z.

Switching on the switch connected to clamp #14 will light led FOTO.

Both switches should be in position so that both leds are off (not illuminating)

On the control box using MODE button turn on led PP

Switch on led SYGNAL Z so that is on permanent.

Switch on led FOTO

Switch off led FOTO

Switch off led SYGNAL Z

In case when you are switching off SYGNAL Z led on the display you will notice "<<" and electric valve should be turned on.

In case when you have FOTO led on and you turn off SYGNAL Z led you will notice on display ">>" and electric valve is not being turned on.

In case when you have SYGNAL Z led on and no FOTO led on you will notice on display ">>" and electric valve is not being turned on.

Foil guide manual instruction.

1. Structure.

Foil guide mechanism contains steering device and executive set. The steering is realized by a photocell XUR Ko955D with the cable XZC P1241L5 from TELEMECANIQUE Company, and photo amplifier WS-1 from AGMA Company. Executive set contains electromagnetic cylinder and bow which moves back the foil.

2. Principle of work.

The photocell works basing on the contrast between foil background and printed photo sign. If the head is adjust on black colour and in the photocell's field of vision is black photo sign, the corrective mechanism would start which causes that the foil moves back about 3mm, for one tact. After this move back in the next tact the photo sign will be outside photocell's view. Then the mechanism will not work. This situation will be repeated till the photo sign will appear in the field of vision, and then the mechanism will start and move back the foil at about 3mm and this situation will appear in order. By correct adjustment of cut length with a little allowance (about 0,2 – 0,5mm) relation to scale of printed signs the correction mechanism start after few dozen of tact.

In case of bright foil print with bright photo sign on the dark background it is necessary to set the head on the bright sign. The correction should start only after move back the foil with the knife. The drive cam gives that guaranty and the microjoint mounted on the shaft which pulls the foil.

3. Preparing for working.

Before sensitivity adjustment it is necessary to check the distance between the foil and photo head. This adjust should be $9\text{mm} \pm 2\text{mm}$.

Before the first activate adjust the outlet head on type NPN with the switch which is available after take off the layer (drawing no. D pos. 2) (the factory adjust of the head is PNP outlet).

Chose the right the right colour of head light due to table which is below

(Table 4)

Background\Sign	White	Blue	Green	Yellow	Orange	Red	Black
White		R or G	R	R or G	G	G	R or G
Blue	R or G		R or G	R or G	R or G	R	R or G
Green	R	R or G		R or G	R or G	R	G
Yellow	R or G	R or G	R or G		R or G	R	G
Orange	G	R or G	R or G	R or G		G	R
Red	G	R	R	R	G		R
Black	R or G	R or G	G	G	R	R	

Info:

R – red light of the head

G - green light of the head

R or G – red or green light of the head

Specification head control elements (draw. D)

- 1. Switch bright (L) – dark (D)
2. Sensitivity control
3. The screw and below the switch for change colour of light
4. Diode showing head outlet
5. Diode, when lighting – head see dark object
6. Diode, when lighting – head see bright object

Pos.2.

Gripper adjust on PNP – head transistor outlet PNP

Gripper adjust on NPN – head transistor outlet NPN

Gripper adjust on DELAY – head delays impulse at 20ms.

Gripper adjust on NOT DELAY – head works without any delays

Change the colour of the light can be made by switching the switch which is available after screw out the screw no. 3 (draw. D)

Adjust the head at the right sign colour (darker or lighter depending from background), according to photo sign printed on the foil, this can be made from switch no. 1 (draw. D).

Shut down the photocell with the switch on photo amplifier. One of two red triangle diodes should start to light (5 or 6), and on the foil material should be seen yellow or red light point from photocell.

Photocell's sensitivity is adjusted by handwheel no.2 (draw. D) on a sign the round diode no.4 and no.5 should light when the head is adjusted on dark sign or diode no. 4 and no.6 when sign is bright. When head is adjusted on the background only diode no.6 should light by the bright background or diode no.5 when background is dark.

Then:

- a) Put on the foil with the sign for photocell printed.
- b) Adjust cut length longer 0,2 – 0,5 mm then printed signs scale on foil (example: for cube 100×75×35mm the cut length is 185mm then adjust cut length on 185,2 – 185,5mm).
- c) Put on the foil into the paper apparatus according to manual instruction and adjust the sign in field of vision (not correct adjustment causes large values of duses, because more time for self adjustments is needed).
- d) Adjust at I lever on the amplifier and console.

4. Disruption and their remove

- photocell doesn't light – check the levers location on the console and amplifier, check the amplifier's power supply
- optic system works correctly, but doesn't make any correction – the adjust of cam's microjoint isn't correct, the action should start at the end of paper cut moment
- the correction system works when the light point form photocell is on the background – correction system should work while there is a photo sign on the field of vision- check the right colour on head switch.
- photocell makes mistakes – not enough contrast on photo sign (check the right light colour on the head), or foil is made with the gloss (inclination of the head according to foil at (5 – 20 degrees is important), there is no tolerance between next photo points – then complain the packing material.

Environnement / Environment
 Température ambiante / Opération : -10 → +55 °C
 Ambient temperature / Stockage : -20 → +70 °C
 °F = °C x 1.8 + 32

Tenue aux vibrations / Vibration resistance
 7g (F : 10 → 55 Hz) (IEC 68-2-6)

Tenue aux chocs / Shocks resistance
 30g ; 3 axes ; 3 fois.
 30g ; 3 axes ; 3 times.

Degré de protection / Degree of protection
 IP 67 (IEC 529)

Matériaux / Materials
 Boîtier / Enclosure : zamac
 Lentilles / Lenses : verre / glass

Caractéristiques électriques / Electrical characteristics
 Type de détecteur / Type of detector : DC, 3 fils, statique / DC, 3 wire type, transistor

Limites de tension / Voltage limits : 10...30 V DC

Courant commuté / Switching capacity : 200 mA

Courant consommé sans charge / Current consumption no-load : ≤ 80 mA

Retards / Delays à l'action / réponse au relâchement / recovery à la mise sous tension / Power up : ≤ 50 µs / ≤ 50 µs / ≤ 100 ms

Fréquence maxi de commutation / Maximum switching frequency : 10 KHz

Mise en œuvre / Setting up procedure
 Portée nominale / Nominal sensing distance : 9 mm ± 2
 Dimensions du spot / Spot dimensions : 1.5 x 5 mm²

Tableau de fonctionnement / Function table

Marque sortie / Dark mark present in the beam	Etat	Etat
DEL rouge / Red LED	Output state	Red LED Output state
Fonction claire / Light-on	○	○
Fonction sombre / Dark-on	⊗	⊗

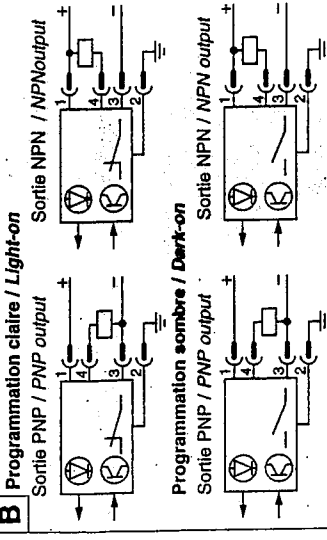
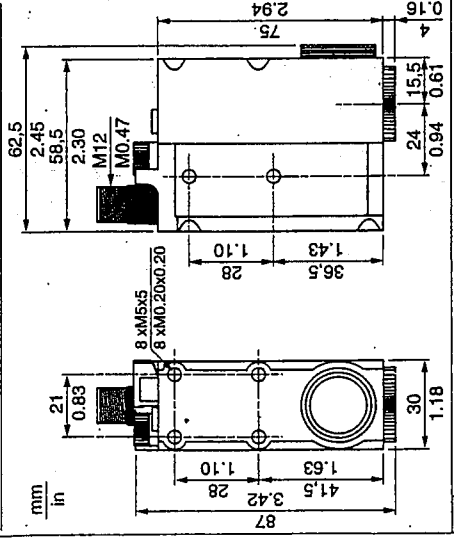
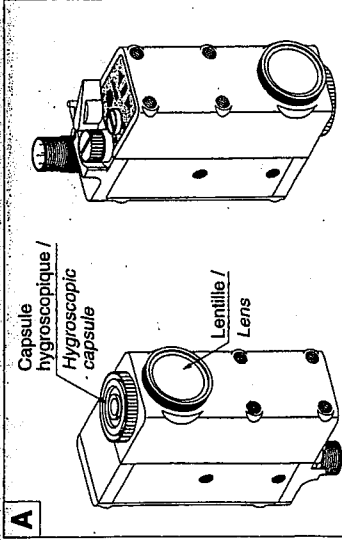

M12

Signal / Signal	Broche / Pin	Couleur / Color
sortie / output	3	Bleu / Blue
+	1	Brun / Brown
Sortie / Output	4	Noir / Black
Terre / Ground	2	Blanc / White



Tableau 4 / Table 4

Marque / Mark	Fond / Background	Blanc / White	Bleu / Blue	Vert / Green	Jaune / Yellow	Orange / Orange	Rouge / Red	Noir / Black
Blanc / White	I	R	I	G	I	R	G	I
Bleu / Blue	I	R	I	R	I	R	G	I
Vert / Green	I	R	I	I	I	R	R	G
Jaune / Yellow	I	R	I	I	I	R	R	R
Orange / Orange	G	I	I	I	I	R	R	R
Rouge / Red	G	I	R	R	R	R	R	R
Noir / Black	I	I	G	R	R	R	R	R

I = rouge ou vert (indifférent) / red or green (indifferent)
 R = rouge / red G = vert / green

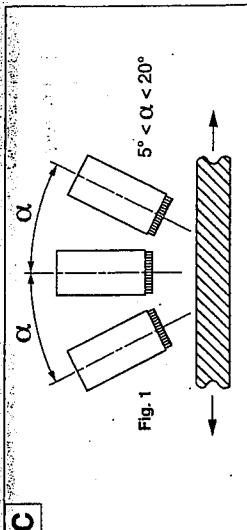
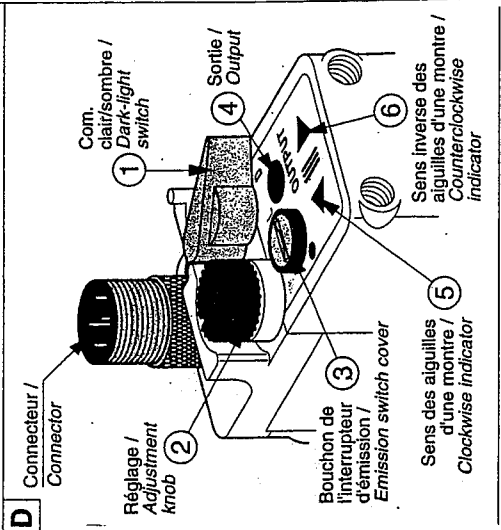

English
 Print registration mark detector

A - Mounting -
 Fixing: Direct by M5 screws
 Side or front

B - Wiring -
 - Before making any connections, check that the detector is compatible with the supply (a.c. or d.c.) and that the rated voltage, as indicated on the detector label, is within the supply voltage limits.
 - Also check the load current characteristics.
 - Do not programme the detector whilst "powered-up".
 - Suitable plug-in cables :
 straight connector, 2 m cable : XZC-P1241L2, 5 m cable : XZC-P1241L5
 elbow connector, 2 m cable : XZC-P1141L2, 5 m cable : XZC-P1141L5
 NB : Pin 2 of the connector on the unit is connected to the case.

C - Setting-up procedure -
 - The detector is delivered ready for use in the lateral mode. For use in the axial mode the lens and hygroscopic capsule/cover should be unscrewed and transposed.
 - For highly reflective or transparent backgrounds, tilt the beam axis by approximately 5° (fig. 1).
 - Select the best beam colour by referring to table 4. The unit is delivered set to "Green". The "Green/Red" selection is made using the "emission" switch, mounted below its cover (3).
 - The unit is delivered programmed for PNP (+ve) output. To programme for NPN (-ve) output, reposition the jumper, accessible by removing the rear cover (fig. 2).
 - The unit incorporates a 20 ms "OFF DELAY". To engage, reposition the jumper, accessible by removing the rear cover (fig. 2). This timer will extend the output signal by 20 ms.

D - Adjustment -
 - For detecting dark marks on a light background :
 1) Set the switch ① to D (Dark-on) position.
 2) Position the light spot on the mark to be detected at a distance of 9 mm.
 3) Turn the adjustment knob in the direction shown by the indicators ⑤ and ⑥ until the output LED changes of state.
 4) Position the light spot on the background at a distance of 9 mm.
 5) Turn the adjustment knob ② in the direction shown by the indicators ⑤ and ⑥ whilst counting the number of turns required to change the state of the output LED.
 Now turn the adjustment knob back half the number of turns just noted.
 - For detecting light marks on a dark background :
 Follow the same procedure but with the switch ① set to the L (Light-on) position.

E - Precautions in use -
 - The detector must be firmly mounted on a rigid support.
 - The lenses must be kept clean. All optical systems are influenced by the environment in which they are situated and the presence of haze, mist, smoke, fumes, steam, dust, etc. can affect their operation by reducing the sensing distance.

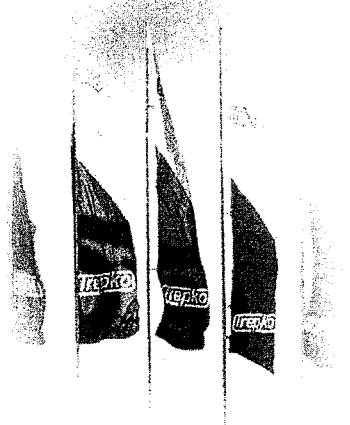

TREPKO Sp. z o.o.
ul. Roosevelta 116, 62-200 Gniezno, Poland

tel. (+48 61) 426 50 41; fax (+48 61) 426 50 18, e-mail: trepko@trepko.pl www.trepko.com

Trepko

**Technical Description
and Operating Manual**

PERFORATING DATE STAMP

typ

XPG-40

GNIEZNO 2012



Technical description and operating manual

Type:
XFG 40-30.00.00

Machine name:
Perforating Date Stamp

page 2

7 pages

C o n t e n t s

1. Application
2. Design description
3. Description of operation
4. Operating manual
5. Needle replacement
6. Maintenance
7. Standard equipment and spare parts list



Technical description and operating manual

Type:
XFG 40-30.00.00

Machine name:
Perforating Date Stamp

page 3 | 7 pages

1. Application

The perforating date stamp is an assembly of butter packing machine type XFG 40. It is used for making numeric code on butter cake packages, for marking the manufacturing date /day, month/ and number of manufacturer plant.

2. Design description

The perforating date stamp consists of following sub-assemblies:

- needle holder
- digit plate seating with digit plates
- seating guide

The needle holder consists of base, lower plate, connecting plate and strap. All these elements are provided with 170 holes in each one. The hole diameter is 1 mm or 1,2 mm. In these holes the needles are placed. In the middle, the plate named slider is located. It is also equipped with holes, in which the needles rest with the shoulder provided in the half of its length.

Over the needle holder the plate seating with replaceable digit plates is mounted. The main part is the top strip, to which all other elements are fixed, forming together the drawer. In this drawer seven digit plates with spottings corresponding to numbers from 0 to 9 are placed. The digit plates are secured against shifting out from the seating by means of strap pressed down by flat spring.



Technical description and operating manual

Type:
XPG 40-30.00.00

Machine name:
Perforating Date Stamp

page 4 | 7 pages

The digit plates seating is fixed to seating guide, which consists of left guide, right guide, connector and holder. In the lower part of the seating guide the needle holder slider is mounted.

The seating guide co-operates with left and right flank of the date stamp.

3. Description of operation

The code on the product package is made by needles, which properly set, form the digit. In each digit field 24 needles are provided. When the packing material is feeded into the date stamp slot, the needles are lifted. Down movement of the seating guide causes shifting down the digit plate seating together with digit plates and the slider. The digit plates press the needles, which pass the slot and the rim of packing material. Because in the digit plates the holes are provided, the needles over which the holes are located are not shifted and do not punch the packing material. During the upward movement of the guide the needles are lifted by the slider over the slot.

4. Operating manual

The perforating date stamp operating consists in changing the digit plates located in the seating according to manufacturing date.

The digit arrangement in the seating is following:

- first three digits from left indicate the number of manufacturer plant
- the next two digits indicate the day
- the last two digits indicate the month

When changing the digits, deflect up the strap in the digit plate seating, remove the particular digit plate and place the new one. Then sink the strap.

Note: The digit change can be carried out only in the top position of the guide, when the digit plates are over the needles

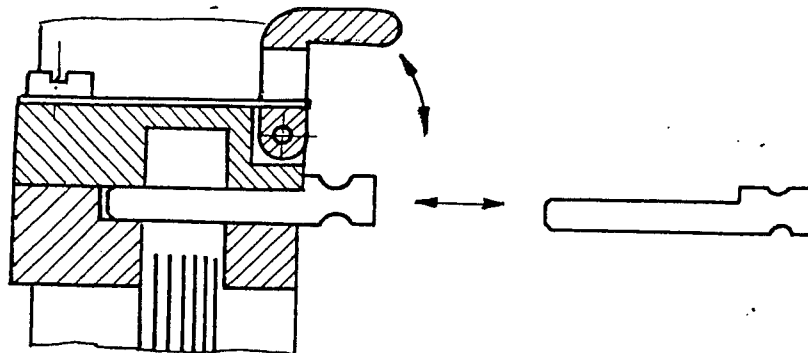

5. Needle replacement

When replacement of damaged needle is needed,

- remove the date stamp from the machine
- disassemble the left and the right flank

- shift the seating guide from the slider
- unscrew 4 screws and remove the top plate
- replace the needle
- assemble the unit in reverse order

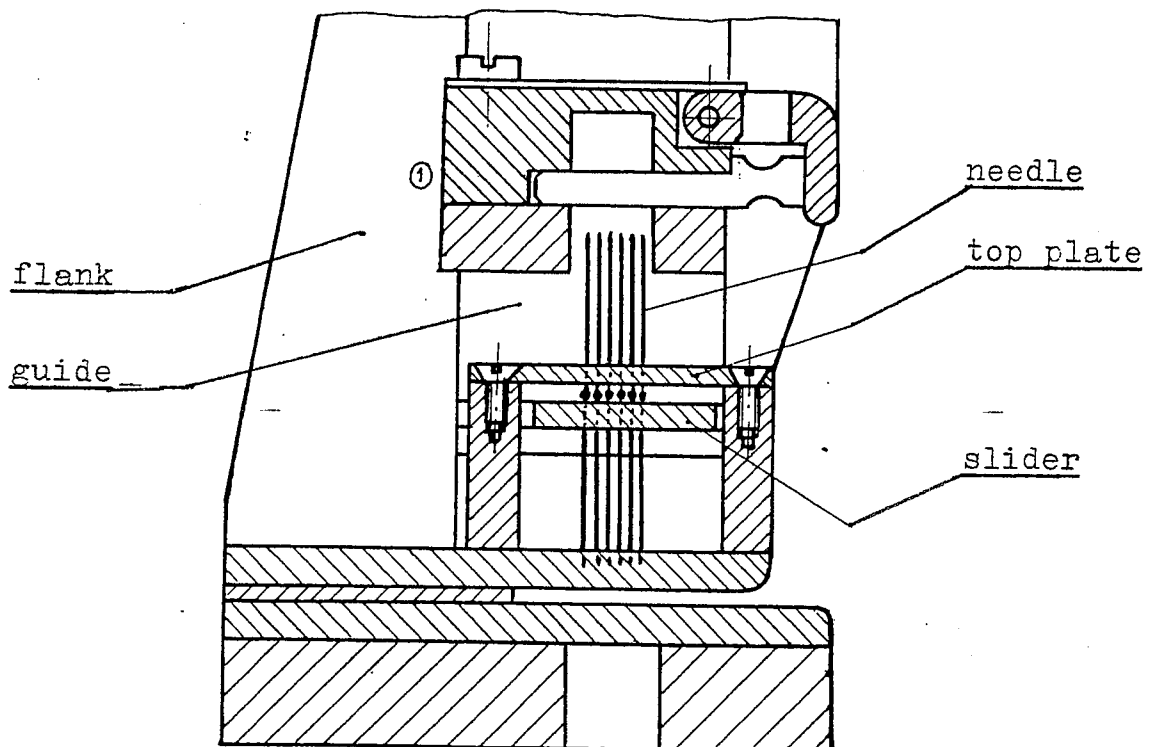

6. Maintenance

The date stamp must be kept in cleanness.



Technical description and operating manual

Type:
XFG 40-30.00.00

Machine name:
Perforating Date Stamp

page 7 | 7 pages

7. Standard equipment and spare parts list

Part name	Quantity		Spare parts
	Standard equipment Date	Plant number	
Digit 0	2		3
Digit 1	4		2
Digit 2	3		1
Digit 3	2		1
Digit 4	2		1
Digit 5	2		1
Digit 6	2		1
Digit 7	2		1
Digit 8	2		1
Digit 9	2		1
Needle	-	-	20

Operating and Maintenance Instructions

Requirements regarding the packing material1. Sorts and dimensions of packing material

The packing machine type XPG 40 is assigned for packing products into aluminium foil and parchment paper.

The aluminium foil as well as parchment paper can be overprinted continuously or singular.

The packing material with singular overprint must be equipped with perforation, it means, with holes with diameter 10 mm, located in the middle line of the band in spaces equal to the cutted sheet length, needed for packing of one cake.

The dimensions of cutted sheets, depending on packing material sort, are given in the table.

Material sort	Format 110×62.6×45		Format		Format	
	Cutting length	Reel width	Cutting length	Reel width	Cutting length	Reel width
Foil	185	230				
Parchment paper	185	230				

Exact dimension data, overprint location and perforation are shown on figures 1, 2, 3, 4 and 5 of this enclosure.

Note: The use of packing material with other length and width dimensions is permissible / so-called economical packages/. The machine manufacturer does not specify dimensions of such packages and is not responsible for possible incorrect packing machine work.

2. Packing material storage

The packing material must be stored in clean rooms, in temperature of 10-20 °C, with relative humidity 67 to 70%. When the storage room is too dry, the packing material becomes brittle, and when too moist - becomes wet. Furthermore, the wet packing material reels are conducive to growth of mould, yeast and microorganisms. It may cause the infection of whole packing material batch and make it waste.

The reels must not be stored directly on the storage room floor. They should be placed on the sticks in distance of 100 mm at least from the floor. Set the reels vertically and secure against overturning, to avoid bends and flatness of packing material. Protect the packing material against the solar radiation.

Note: The incorrectly stored packing material always causes troubles in packing machine work.

Dimensions for packaging material for format 110x62.6x45
Overprint on lined fields of surface layer

A recommended packaging material for packing butter is aluminium foil
(thickness of aluminium layer is 0.007-0.010 mm) laminated with parchment paper.
Thickness of foil is 0.07-0.08 mm.

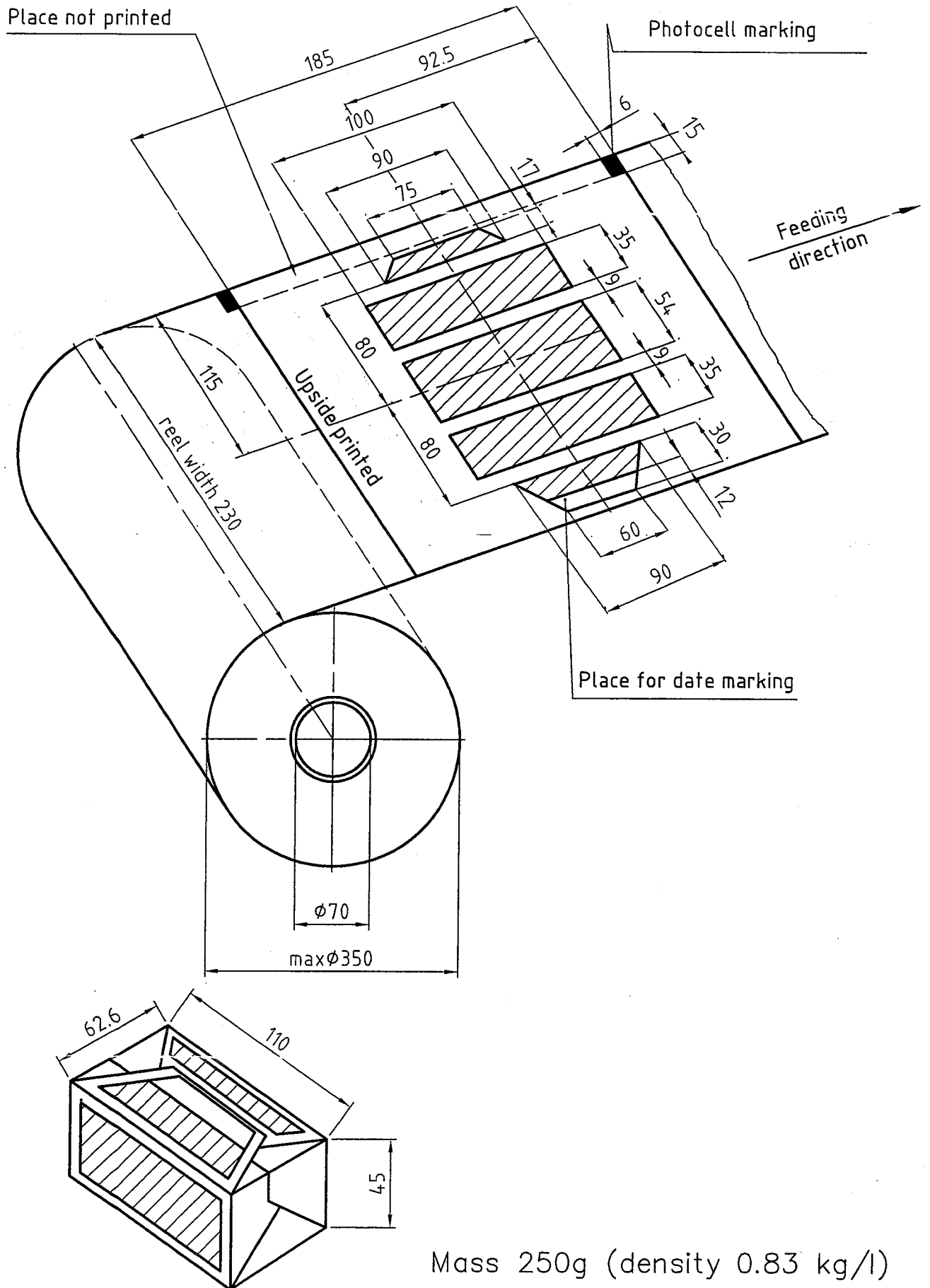

Mass 250g (density 0.83 kg/l)

Settings

01.07.2014 11:58

1. Recommended maintenance of the packaging machine during runnin in period:

- (i) first month – lubrication 2 x week
- (ii) 1 x week onwards

2. Mounting and preparation before running the machine:

(i) Categorical ban of mounting of the filling nozzle on the machine !!!
Mounting of the nozzle as well as dosing slider with knife should be assembled away from the machine and installed as a assembled parts by tightening the clamp with flange nut M12.

(ii) Assembling of the cylinder slide and pistons should be proceded by prior covering them with / greasing them with fat.

(iii) Having done (ii) you need to release breake pressing break button on the control panel and then using manual side wheel turn it one full cycle to make sure all is properly mounted.

(iv) Then using step button on the control panel run the machine for a couple of cycles making sure all functions correctly. Then use both green buttons for continous running mode of the machine.

(v) Proper brick shape can be obtained by adjusting the leaver below dosing slider trying to get the lowest brick hight and then adjust the leaver below wrappers/folders.

(vi) During machine running it's very important to check the paper brake and make sure it doesn't cause paper cut back or retreat.

(vii) When packing hard butter the paper piston cam needs to be accelerated by turning it slightly in the direction („UP”).

In case of softer butter do the opposite. (on the 125g machnie there are arrows up and down with „H” for hard butter and „S” for soft butter.

PAPER ADJUSTMENTS

01.07.2014 11:58

1. Switch off the photo cell panel
2. Set paper on photo cell mark and knife cut fragment
3. Take out second paper length before it's formed by alu piston
4. Switch the machine on in continuous mode (2 green buttons)
5. Stop the machine on the 5-6th paper length before it's formed by piston and take it out.
6. Compare both cut paper bits looking at the photo marker.
7. The 5th-6th paper marker should be shifted with respect to the second paper about 4 mm in direction of the paper movement.
8. In case paper shifts back against the paper movement it means paper length is set too short.
9. In order to make paper cut longer you should loosen screw on roller located before the knife. Roller rings should be moved clockwise by a very small margin in order to obtain longer paper cut. Moving roller ring by 2mm doesn't mean paper is longer by 2 mm. In fact it will be much longer.
10. When paper length is set correctly (like in point 7) switch on the photo cell panel and carry on production.

ADDITIONAL SET OF COMPLETING PARTS FOR MACHINE XPG40 No 1006

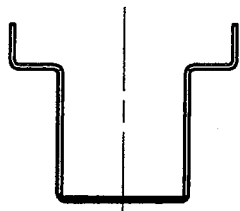

Cutter 121-74-05-01 pcs.1

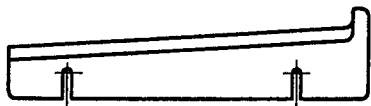

Knife 128-02-127-2 pcs.1

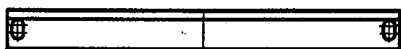

Knife 128-03-25-2 pcs.1



Spring 12.5x1x45 pcs.2



Spring 10x1x15 pcs.2



Spring 12.5x1.5x50 pcs.1



Spring 16x2x40 pcs.2



Spring 12.5x1.6x30 pcs.2



Spring 19x2.5x13 pcs.1



Spring 18x2x75 pcs.2



Spring 20x3x320 pcs.1



Spring 20x2.5x365 pcs.4



Spring 20x2.5x260 pcs.4



Spring 18x2x95 pcs.4



Spring 7x0.5x45 pcs.4



Spring 18x2x120 pcs.1



Spring 10x1x60 pcs.2



Spring 13x1.5x150 pcs.4



Spring 10x1x115 pcs.1



Spring 15x1.5x115 pcs.2



Spring 18x2x220 pcs.2



Spring 13x1.2x60 pcs.1



Spring 121-17-08-00 20x3x400 pcs.2

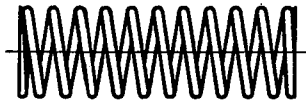

Spring 121-04-04-04 41.5x5.5x190 pcs.2



Spring 121-04-04-03-1 39x3.5x190 pcs.2



Spring 128-07-33-05 40.5x4.5x190 pcs.2



Clamp BHN 5538/1 pcs.9



Hose 6x1.5 3m



Sleeve of hose 6x1.5 pcs.9

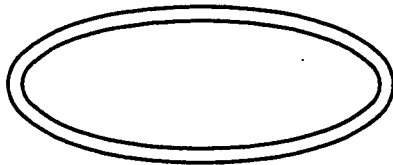

Belt B-1800 pcs.2

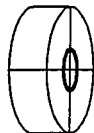

Cam roll 40 BHN405.1 pcs.1

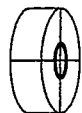

Cam roll 30 BHN405.1 pcs.1

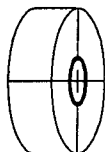

Cam roll 49.8 BHN405.1 pcs.2

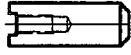

Pin 16x51 BHN 405.2 pcs.1

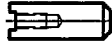

Pin 10x31 BHN 405.2 pcs.1

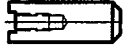

Pin 13x38 BHN 405.2 pcs.1



Sealing ring OR 69.2x5.7-70Si pcs.4



Fastener 6210-020-001 BHN 6210 pcs.4



Fastener 6210-020-002 BHN 6210 pcs.4



Needle for date stamp pcs.25

EQUIPMENT FOR MACHINE XPG40 No 1006

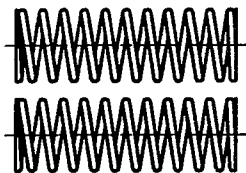

Spring 121-04-04-03-1 39x3.5x190 pcs.1

Spring 128-07-33-05 40.5x4.5x190 pcs.1

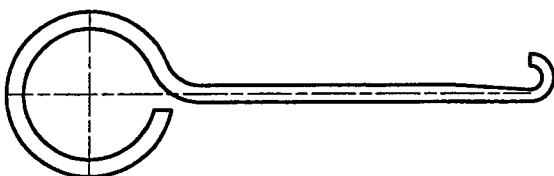

Hook for mantage of springs pcs.1

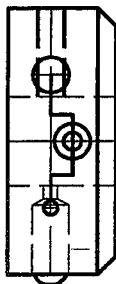

Ring \varnothing 75 for packaging material pcs.2

Tool kit case 1

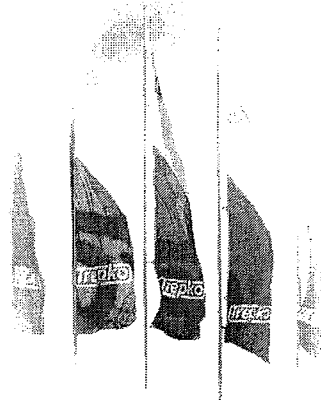

TREPKO Sp. z o.o.
ul. Roosevelta 116, 62-200 Gniezno, Poland

tel. (+48 61) 426 50 41; fax (+48 61) 426 50 18, e-mail: trepko@trepko.pl www.trepko.com

Trepko

Spare Parts Catalogue
PACKING MACHINE

typ

XPG-40

GNIEZNO 2006

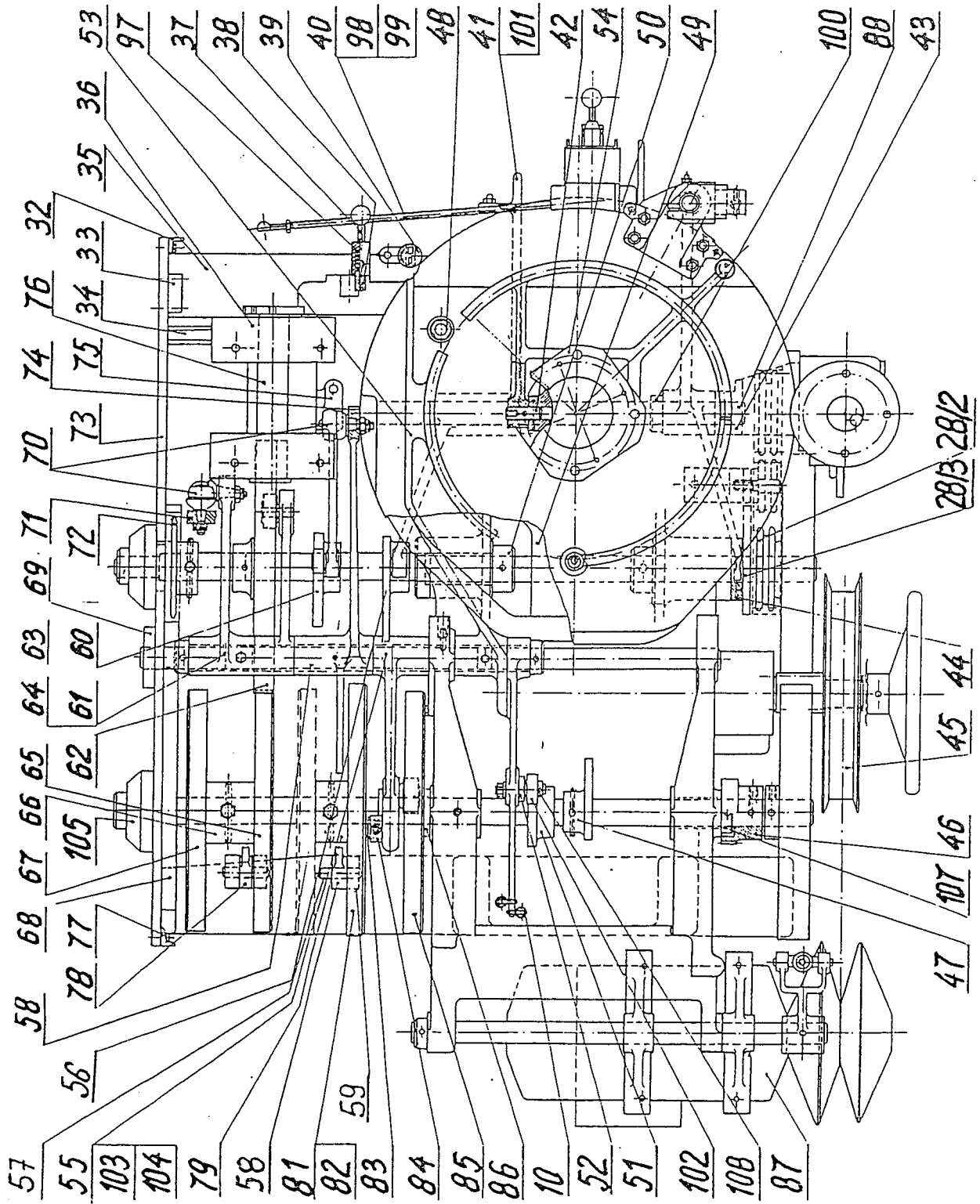

Fig. 01

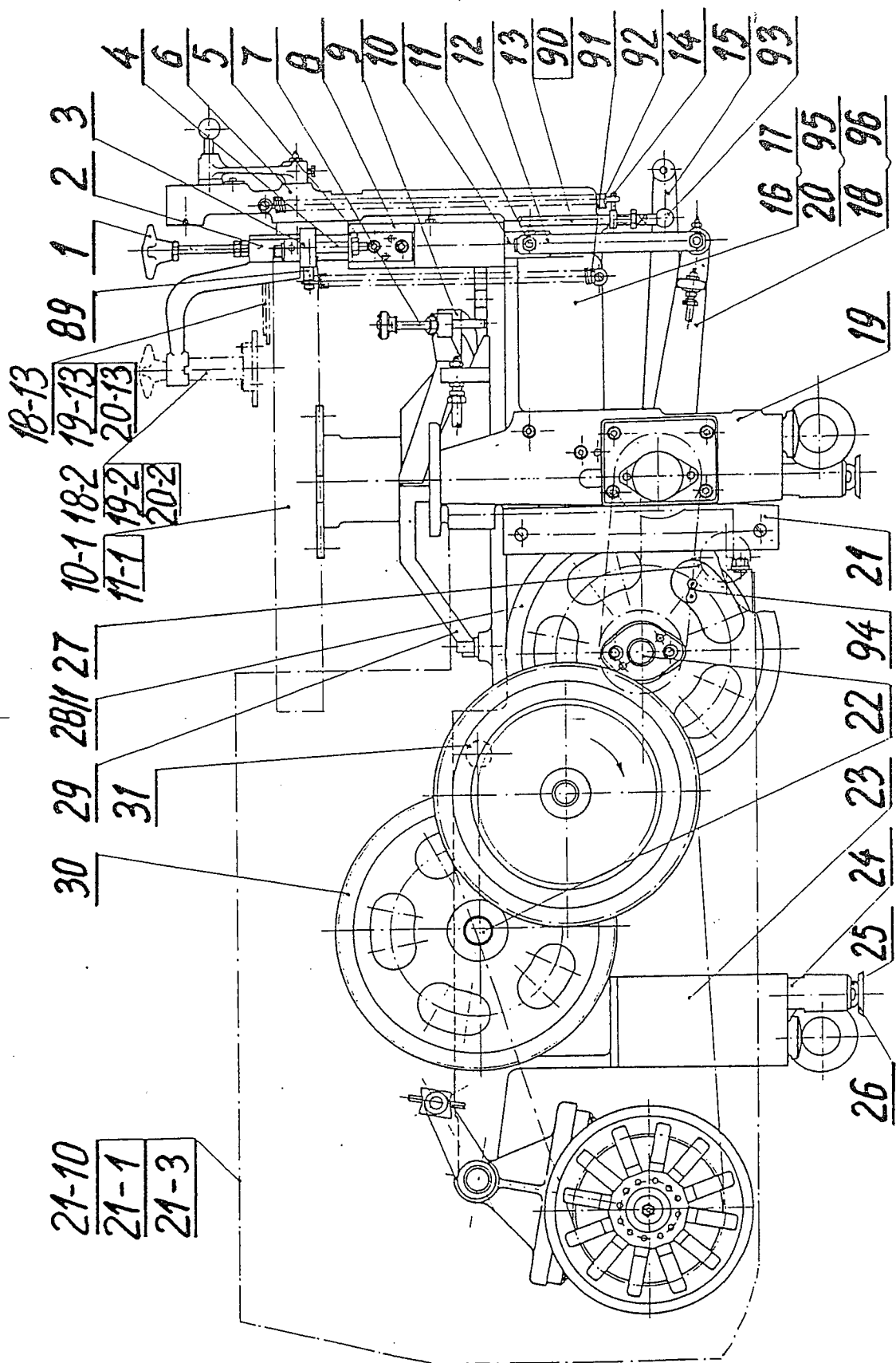

Fig. 01



Packing Machine XPG40
Spare parts catalogue

Operating and
Maintenance Instr.

page 3

90 pages

Fig.01 - Drive unit XPG 40-01-00-00

Part No	Group	Drawing No	Part name	Qty	Notes
01-1	B	XPG 40-01-01-00	Adjusting screw	1	
01-2		XPG 40-01-02-00	Bracket	1	
01-3	B	XPG 40-01-00-03	Clamping ring	1	
01-4	B	XPG 40-01-00-04	Pin	1	
01-5		XPG 40-01-00-05	Bracket	1	
01-6		XPG 40-01-06-00	atcher switch	1	Sub-ass. Drwg.01/2
01-7		XPG 40-01-07-00	Adjusting screw	1	
01-8		XPG 40-01-08-00	Bracket	1	
01-9	B	XPG 40-01-00-09	Guide	1	
01-10	B	XPG 40-01-00-10	Fusher	1	
01-11	B	XPG 40-01-00-11	Pin	2	
01-12		XPG 40-01-00-12	Connector	2	
01-13		XPG 40-01-00-13	Connector	2	
01-14		XPG 40-01-14-00	Ring with catch	2	
01-15		XPG 40-01-00-15	Lever	1	
01-16		XPG 40-01-16-00	Body	1	
01-16/1	B	XPG 40-01-16-02	Sleeve	1	
01-16/2	B	XPG 40-01-16-03	Sleeve	1	
01-16/3	B	XPG 40-01-16-04	Sleeve	2	
01-17		XPG 40-01-00-17	Cover	1	
01-18		XPG 40-01-18-00	Lever	1	
01-18/1	B	BHN-5640-351-030B	Sleeve	2	
01-18/2	B	BHN-5640-131-620A	Sleeve	1	
01-19		XPG 40-01-19-00	Conveyor drive	1	Sub-ass. Drwg.01/3
01-20	B	LW 54-01-38a	Sight-glass	1	
01-21		XPG 40-01-00-21	Holder	1	
01-22	B	XPG 40-01-00-22	Cam shaft	2	
01-23		XPG 40-01-00-23	Base	1	
01-24		XPE 50-01-100	Body nut	4	
01-25		XPE 50-01-101	Adjusting screw	4	
01-26	B	XPE 50-01-102	Foot	4	
01-27	B	XPG 40-01-27-00	Chain stretcher	1	
01-28		XPG 40-01-28-00	Gear complete	1	
01-28/1	B	XPG 40-01-28-01	Gear z=121	1	



Fig.01 - Drive unit XPG 40-01-00-00

Part No	Group	Drawing No	Part name	Qty	Notes
01-28/2	B	XPG 40-01-28-02	Chain wheel	1	
01-28/3	B	XPG 40-01-28-03	Cam	1	
01-29	B	XPG 40-01-00-29	Guide	1	
01-30	E	XPG 40-01-00-30	Gear z=121	1	
01-31	B	XPG 40-01-00-31	Shaft	1	
01-32		XPG 40-01-00-32	Angle steel	1	
01-33		XPG 40-01-00-33	Angle steel	1	
01-34		XPG 40-01-00-34	Distance pin	1	
01-35		XPG 40-01-00-35	Bracket	1	
01-36		XPG 40-01-00-36	Ease	1	
01-36/1	E	EHN-5640-354-050	Sleeve	1	
01-37		XPG 40-01-00-37	Mandrel	1	
01-38		XPG 40-01-00-38	Pivot	1	
01-39		XPG 40-01-39-00	Set block	1	
01-40		XPG 40-01-00-40	Connector	1	
01-41		XPG 40-01-41-00	Lever	1	
01-41/1	B	EHN-5640-354-050E	Sleeve	2	
01-42	E	XPG 40-01-00-42	Pin	1	
01-43		XPG 40-01-43-00	Bracket	1	
01-43/1	E	EHN-5640-354-040A	Sleeve	1	
01-44		XPG 40-01-00-44	Flange	2	
01-45		XPG 40-01-45-00	Shaft drive	1	Sub-ass. Drwg.01/4
01-46	E	XPG 40-01-00-46	Gear z=34	1	
01-47	B	XPG 40-01-00-47	Cam	1	
01-48		EHN 5083	Plug	1	
01-49		XPG 40-01-00-49	Cam	1	
01-50		XPG 40-01-00-50	Retaining ring	2	
01-51	B	XPG 40-01-00-51	Cam	1	
01-52	E	XPG 40-01-00-52	Pin	1	
01-53		XPG 40-01-53-00	Lever complete	1	
01-53/1	E	EHN-5640-354-035E	Sleeve	1	
01-53/2	B	EHN-5640-354-060E	Sleeve	1	
01-54		XPG 40-01-54-00	Head drive	1	Sub-ass. Drwg.01/5
01-55		XPG 40-01-55-00	Lever	1	



Packing Machine XPG40
Spare parts catalogue

Operating and
Maintenance Instr.

page 5

90 pages

Fig.01 - Drive unit XPG 40-01-00-00

Fart No	Gro- up	Drawing No	Fart name	Qty	Notes
01-55/1	B	EHN-5640-354-035E	Sleeve	2	
01-56	E	XPG 40-01-00-56	Cam	1	
01-57		XPG 40-01-57-00	Connector complete	1	
01-57/1	B	1999-260-041	Joint SF 16	1	Import
01-57/2	E	1999-260-051	Joint SF 16L	1	Import
01-58		XPG 40-01-58-00	Lever complete	1	
01-58/1	E	EHN-5640-354-050E	Sleeve	2	
01-59	B	XPG 40-01-00-59	Pin	1	
01-60	B	XPG 40-01-00-60	Cam	1	
01-61		XPG 40-01-61-00	Lever	1	
01-61/1	B	EHN-5640-354-060E	Sleeve	2	
01-62	B	XPG 40-01-00-62	Cam	1	
01-63	A	EHN 405.2	Pin 16x51	1	
01-64	A	BHN 405.1	Roller 50	1	
01-65	E	XPG 40-01-00-76	Cam	1	
01-66	B	XPG 40-01-00-77	Hub	1	
01-67	B	XPG 40-01-00-78	Cam	1	
01-68		XPG 40-01-00-79	Angle steel	1	
01-69		XPG 40-01-80-00	Bearing	2	
01-69/1	E	XPG 40-01-80-02	Sleeve	1	
01-70		XPG 40-01-81-00	Connector	2	
01-70/1	B	025-8143-364-000	Ball-and-socket joint	2	Import
01-70/2	E	025-8143-374-000	Ball-and-socket joint	2	Import
01-71		XPG 40-01-00-82	Lever	1	
01-72	E	XPG 40-01-00-83	Chain wheel	1	
01-73		XPG 40-01-00-86	Side wall	1	
01-74		XPG 40-01-00-87	Bracket	1	
01-75		XPG 40-01-00-88	Lever	1	
01-76		XPG 40-01-89-00	Eccentric pipe	1	
01-76/1	B	XPG 40-01-89-03	Sleeve	2	
01-77		XPG 40-01-00-90	Angle steel	1	
01-78		XPG 40-01-91-00	atcher lever	1	Sub-ass. Drwg.01/6
01-79	B	XPG 40-01-00-92	Hub	1	



Fig.01 - Drive unit XPG 40-01-00-00

Part No	Group	Drawing No	Part name	Qty	Notes
01-80		XPG 40-01-93-00	Lever complete	1	Sub-ass. Drwg.01/7
01-81	B	XPG 40-01-00-94	Cam	1	
01-82	B	XPG 40-01-00-95	Cam	1	
01-83	B	XPG 40-01-00-96	Pin	1	
01-84		XPG 40-01-97-00	Connector	1	
01-84/1	B	EHN-5640-253-025A	Sleeve	2	
01-85	B	XPG 40-01-00-98	Punch cam	1	
01-86	B	XPG 40-01-00-100	Washer	1	
01-87		XPG 40-01-101-00	Main drive	1	Sub-ass. Drwg.01/8
01-88	B	XPG 40-01-00-110	Shaft	1	
01-89		EHN 6212	Catch 6212-102-001	1	
01-90	B	EHN 5405	Joint head A16	2	
01-91	A	EHN 420	Spring 20x3x320	1	
01-92	A	EHN 420	Spring 20x2,5x365	2	
01-93	B	EHN 5406	Ball-and-socket joint A16	2	
01-94		PN-67/L-84168	Pitch chain 10E -2-54 ps	1	
01-95		EHN 5080	Plug R3/4x16	1	
01-96	A	EHN 4054	Roller complete 40/13x38A	2	
01-97	B	EHN 421	Spring 12,5x1x40	1	
01-98	B	EHN 5405	Joint head A13	1	
01-99	B	EHN 5405	Joint head 1.A13	1	
01-100	B	EHN 5231	Retaining ring A35	7	
01-101	A	EHN 4054	Roller complete 41/13x38A	1	
01-102	A	EHN 405.1	Roller 40	1	
01-103	A	EHN 405.2	Pin 16x51	1	
01-104	A	EHN 405.1	Roller 50	1	
01-105			Bearing complete RCJ35	2	Import
01-106	A	EHN 420	Spring 20x25x260	2	
01-107	B	EHN 5231	Retaining ring A40	1	
01-108	B	EHN 5231	Retaining ring A13	1	

Трепко

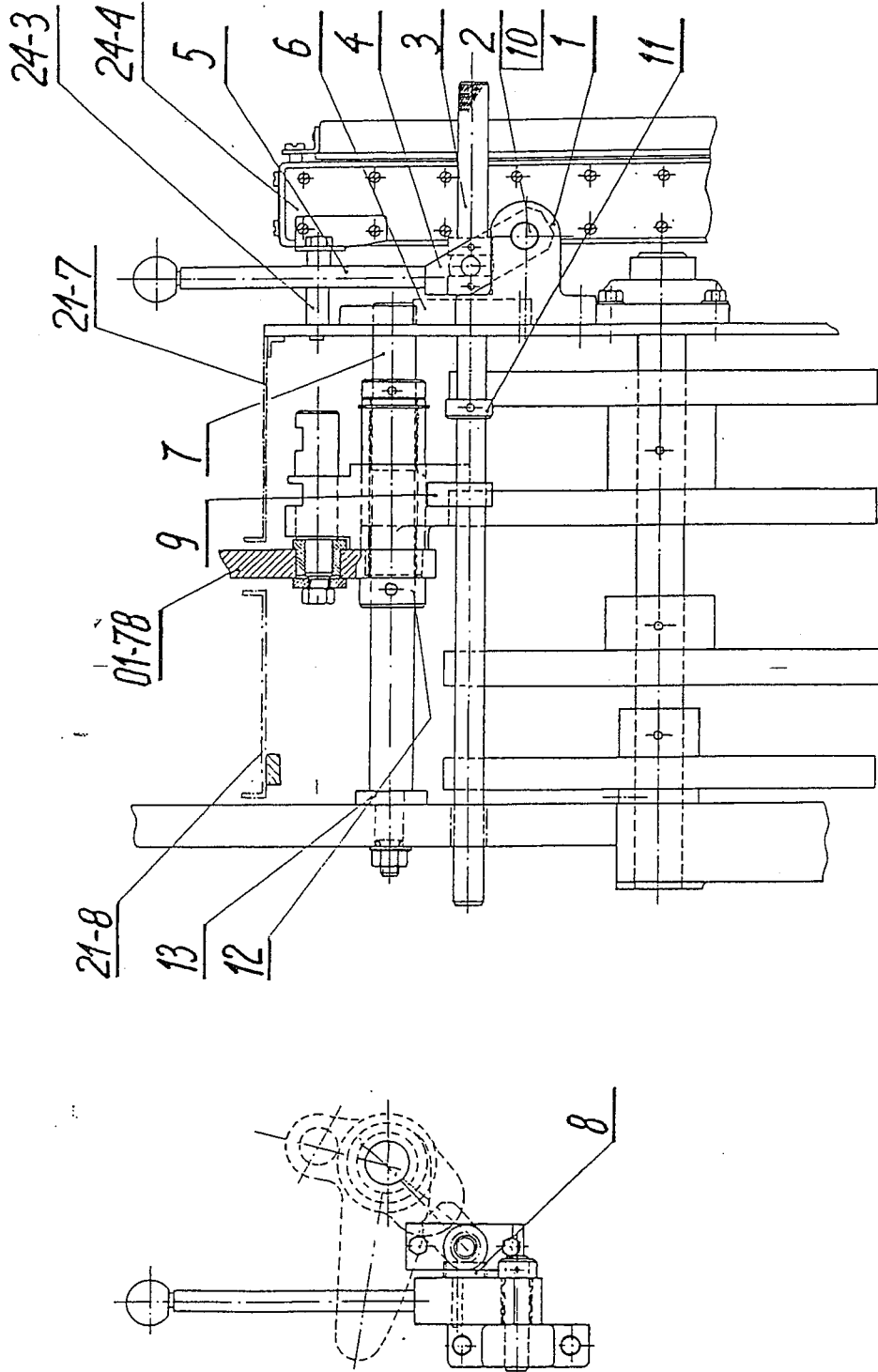

Fig. 01/1



Packing Machine XPG40
Spare parts catalogue

Operating and
Maintenance Instr.

page 8 90 pages

Fig.01/1 - Drive unit XPG 40-01-00-00

Part No	Group	Drawing No	Part name	Qty	Notes
01/1-1		XPG 40-01-00-102	Bracket	1	
01/1-2		XPG 40-01-00-103	Axle	1	
01/1-3		XPG 40-01-104-02	Axle	1	
01/1-4		XPG 40-01-105-00	Lever	1	
01/1-5		XPG 40-01-00-106	Arm	1	
01/1-6		XPG 40-01-107-00	Bearing	1	
01/1-7	B	XPG 40-01-00-108	Axle	1	
01/1-8		XPG 40-01-00-109	Slider	1	
01/1-9		XPG 40-01-104-01	Slide block	1	
01/1-10		EHN 5231	Retaining ring A20	1	
01/1-11		EHN 5231	Retaining ring A25	3	
01/1-12	B	EHN 5231	Retaining ring A35	2	
01/1-13		EHN 5232	Washer 5232-025- -007	1	

Trepko

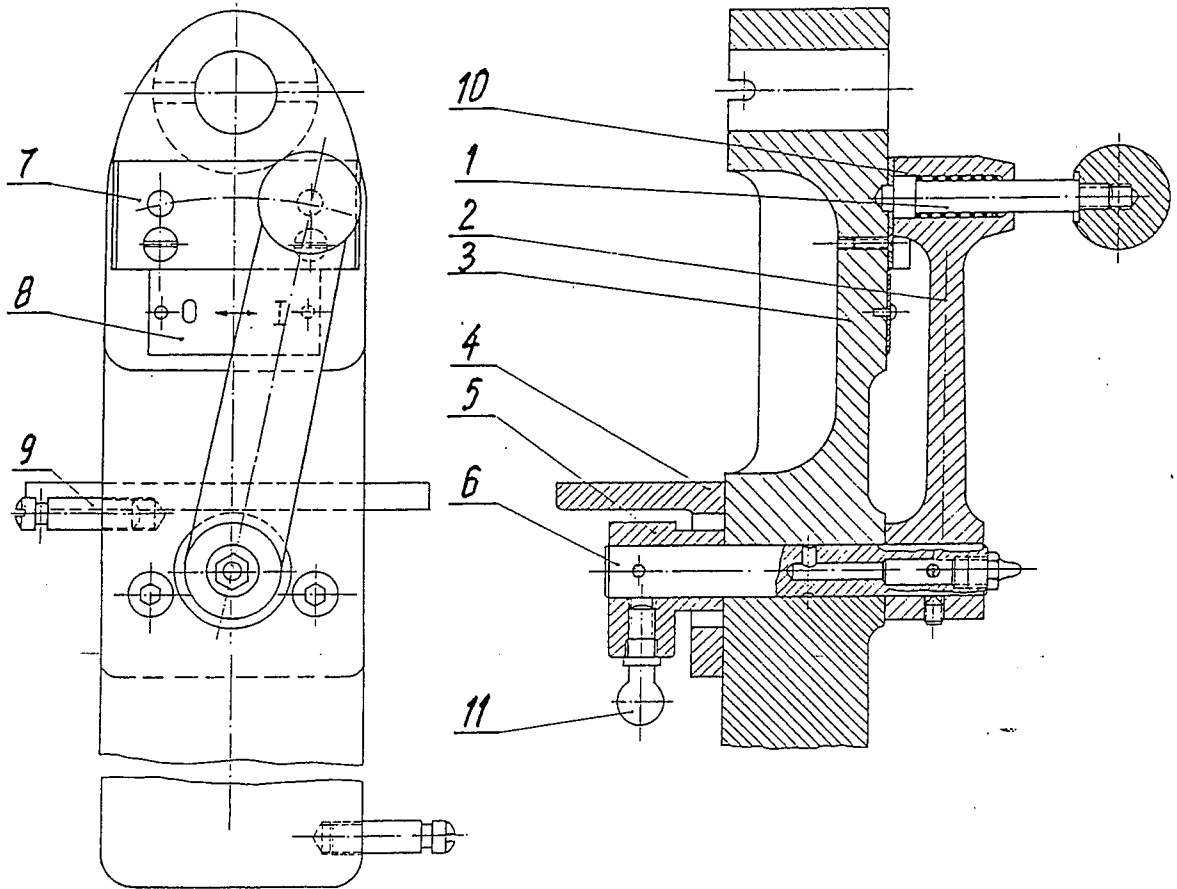

Fig. 01/2



Packing Machine XPG40
Spare parts catalogue

Operating and
Maintenance Instr.

Page 10 90 pages

Fig.01/2 - Eatcher cut-off XPG 40-01-06-00

Part No	Group	Drawing No	Part name	Qty	Notes
01/2-1		XPG 40-01-06-01	Pin	1	
01/2-2		XPG 40-01-06-02	Lever	1	
01/2-3		XPG 40-01-06-03	Body	1	
01/2-4		XPG 40-01-06-04	Angle steel	1	
01/2-5		XPG 40-01-06-05	Lever	1	
01/2-6		XPG 40-01-06-06	Pin	1	
01/2-7		XPG 40-01-06-07	Shield	1	
01/2-8		XPG 50-06-39	Plate 1999-810-830	1	
01/2-9		BHN 6212	Catch 6212-102-001	2	
01/2-10		BHN 421	Spring 12,5x1x45	1	
01/2-11		BHF 5404	Ball pivot A13	1	

Trepko

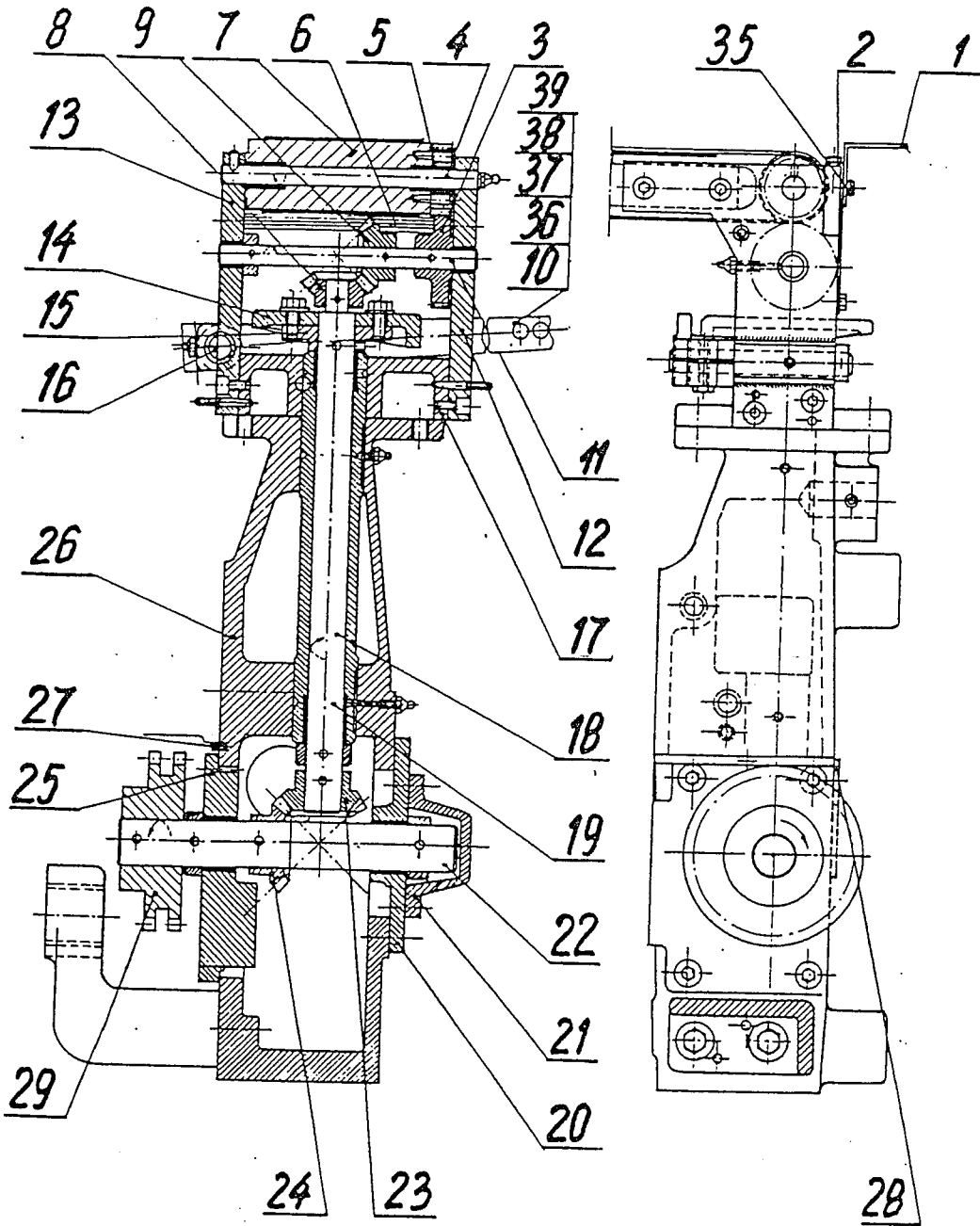

Fig. 01/3



Fig.C1/3 - Conveyor drive XPG 40-01-19-00

Part No	Group	Drawing No	Part name	Qty	Notes
01/3-1		XPG 40-01-19-01	Guide	1	
01/3-2		XPG 40-01-19-02	Cover	1	
01/3-3		XPG 40-01-19-03	Gear z=33	1	
01/3-4	B	XPG 40-01-19-04	Axle	1	
01/3-5		XPG 40-01-19-05	Gear z=22	1	
01/3-6		XPG 40-01-19-06	Connector	1	
01/3-7	B	XPG 40-01-19-07	Roller complete	1	
01/3-8		XPG 40-01-19-08	Gear z=16	1	
01/3-9		XPG 40-01-19-09	Gear z=20	1	
01/3-10		XPG 40-01-19-10	Lever	1	
01/3-11	B	XPG 40-01-19-11	Shaft	1	
01/3-12/1	B	BHN-5640-162-015A	Sleeve	1	
01/3-12		XPG 40-01-19-12	Side wall I	1	
01/3-13		XPG 40-01-19-13	Side wall II	1	
01/3-13/1	B	BHN-5640-162-020E	Sleeve	2	
01/3-13/2	B	BHN-5640-162-015A	Sleeve	1	
01/3-14	B	XPG 40-01-19-14	Cam	1	
01/3-15		XPG 40-01-19-15	Flange	1	
01/3-16	B	XPG 40-01-19-16	Shaft	1	
01/3-17		XPG 40-01-19-17	Connector	1	
01/3-18		XPG 40-01-19-18	Bearing	1	
01/3-18/1	B	BHN-5640-253-025A	Sleeve	1	
01/3-18/2	B	BHN-5640-253-035A	Sleeve	1	
01/3-19	B	XPG 40-01-19-19	Shaft	1	
01/3-20		XPG 40-01-19-20	Cover	1	
01/3-20/1	B	BHN-5640-303-525A	Sleeve	1	
01/3-21		XPG 40-01-19-21	Cover	1	
01/3-22	B	XPG 40-01-19-22	Shaft	1	
01/3-23		XPG 40-01-19-23	Gear z=16	1	
01/3-24		XPG 40-01-19-24	Gear z=16	1	
01/3-25		XPG 40-01-19-25	Flange	1	
01/3-25/1		BHN-5640-303-525A	Sleeve	1	
01/3-26		XPG 40-01-19-26	Body	1	
01/3-27		XPG 40-01-19-27	Stop	1	
01/3-28		XPG 50-01-204	Closing cap	1	



Packing Machine XPG40
Spare parts catalogue

Operating and
Maintenance Instr.

page 13 **90** pages

Fig.01/3 - Conveyor drive XPG 40-01-19-00

Part No	Group	Drawing No	Part name	Qty	Notes
01/3-29	E	XPG 40-01-19-29	Gear z=23	1	
01/3-35		EHN-5079	Screw-in pin 5079- -006-013	2	
01/3-36	A	EHN 405U	Roller complete 30/10x30A	1	
01/3-37	L	BHN 5404	Ball pivot A13	1	
01/3-38	A	BHN 420	Spring 18x2x75	1	
01/3-39		EHN 6211	Catch 621 1006-018	2	

Trepko

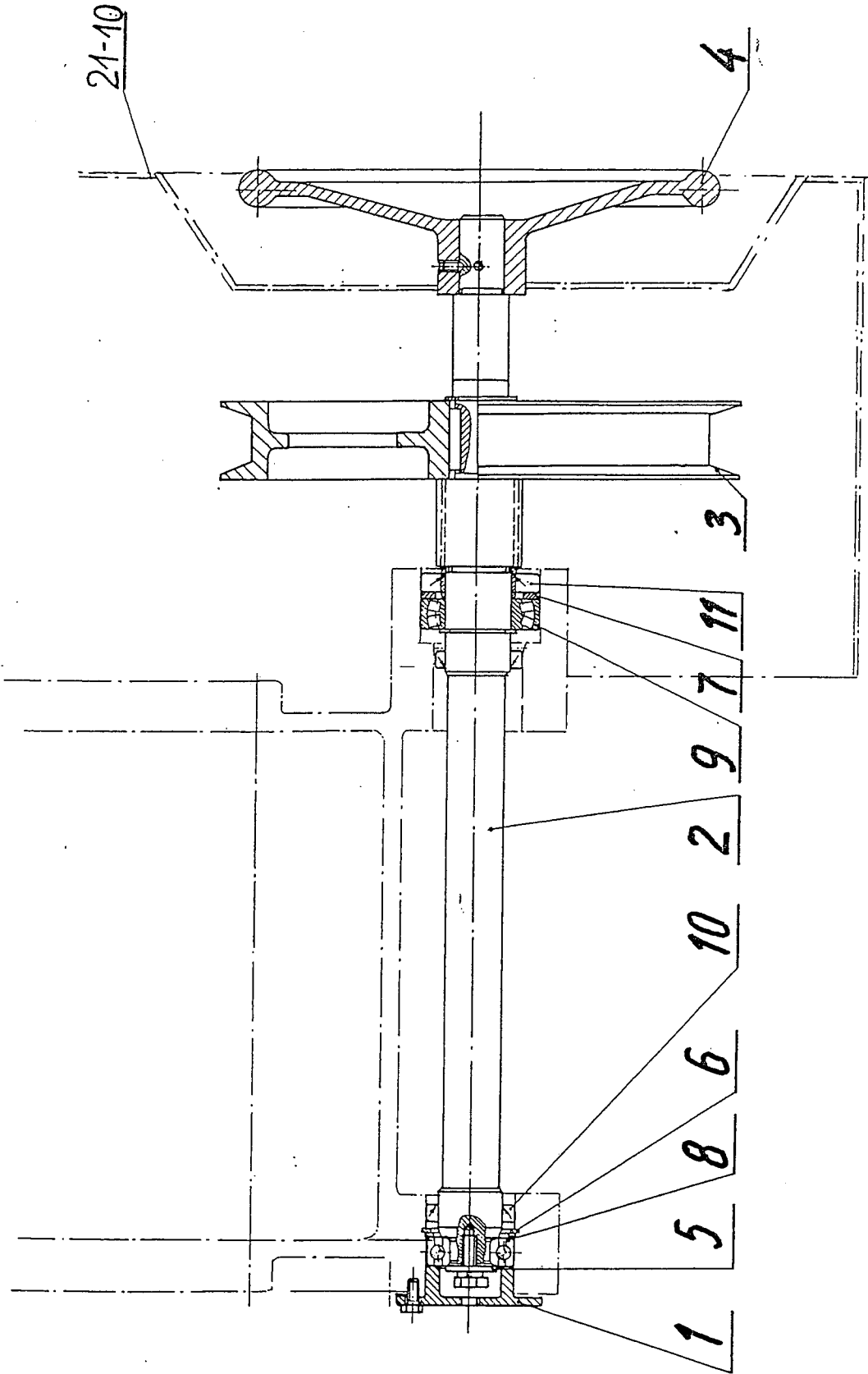

Fig. 01/4



Packing Machine XPG40
Spare parts catalogue

Operating and
Maintenance Instr.

page 15

90 pages

Fig.01/4 - Shaft drive XPG 40-01-45-00

Part No	Group	Drawing No	Part name	Qty	Notes
01/4-1		XPG 40-01-45-01	Cover	1	
01/4-2	B	XPG 40-01-45-02	Shaft complete	1	
		XPG 40-01-45-02/1	Shaft	1	
		XPG 40-01-45-02/2	Distance ring	1	
01/4-3	B	XPG 40-01-45-03	Pulley	1	
01/4-4		XPG 40-01-45-04	Hand wheel	1	
01/4-5		EHN 5232	Washer 5232-010. 005	1	
01/4-6		EHN 5232	Washer 5235-50	1	
01/4-7		EHN 5235	Washer 5235-65	1	
01/4-8		PN-69/M-86100	Bearing 6305	1	
01/4-9		PN-70/M-86240	Bearing 22209A	1	
01/4-10		PN-66/M-86960	Seal ring E45x62x 10	2	
01/4-11		PN-66/M-86960	Seal ring E55x85x10	1	

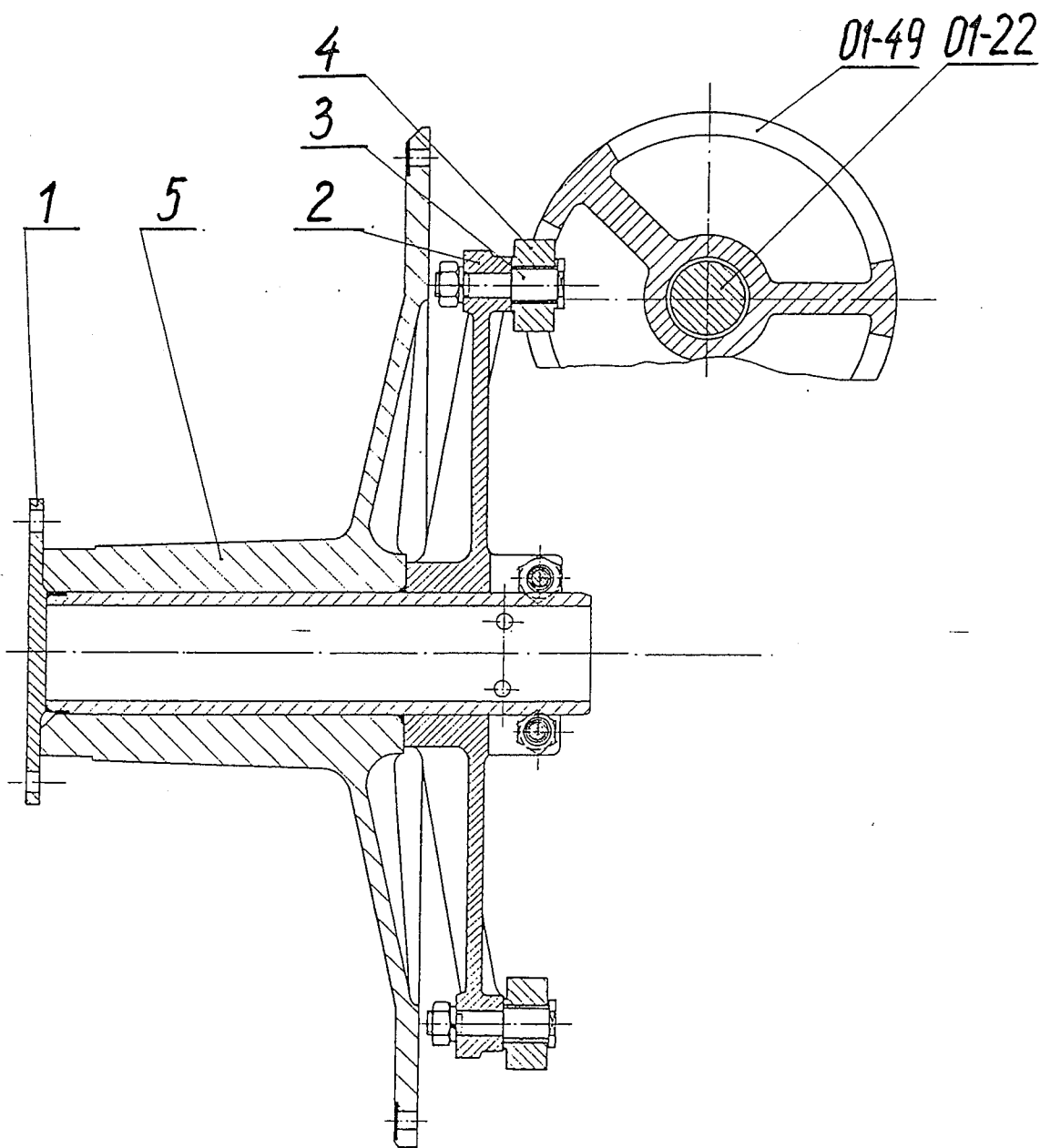

Fig. 01/5



Packing Machine XFG40
Spare parts catalogue

Operating and
Maintenance Instr.

page 17

90 pages

Fig.01/5 - Head drive XPG 40-01-54-00

Part No	Group	Drawing No	Part name	Qty	Notes
01/5-1		XPG 40-01-54-01	Revolving table shaft	1	
01/5-2		XPG 40-01-54-02/3	Drive wheel	1	
01/5-3	B	XPG 40-01-54-02/1	Pin	8	
01/5-4	E	XPG 40-01-54-02/2	Roller	8	
01/5-5		XPG 40-01-54-03	Cover	1	

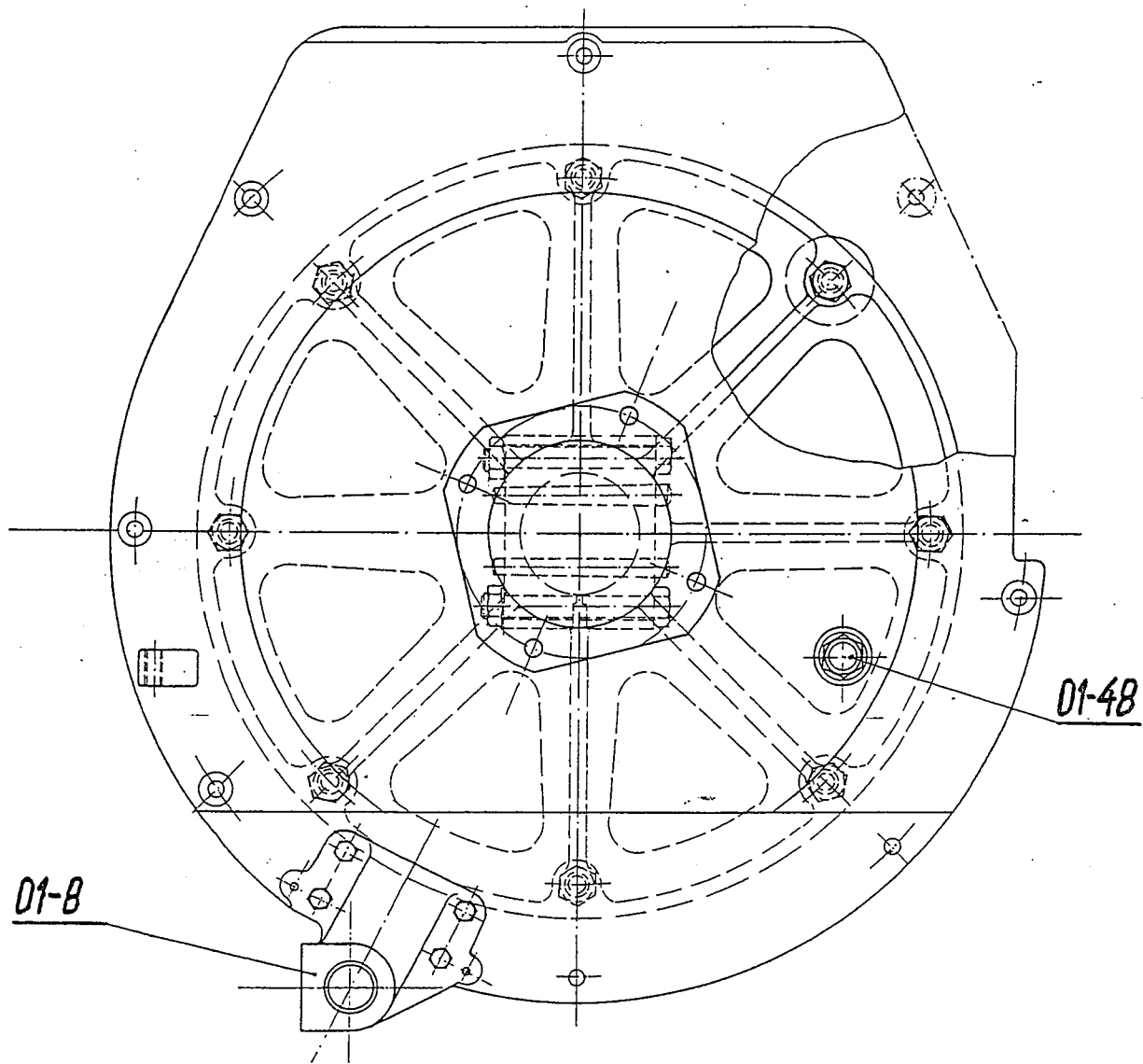

Fig. 01/5



Packing Machine XPG40
Spare parts catalogue

Operating and
Maintenance Instr.

page 19

90 pages

Fig.01/6 Batcher lever XPG 40-01-91-00

Part No	Group	Drawing No	Part name	Qty	Notes
01/6-1	A	XPG 40-01-91-01	Pin	1	
01/6-2	A	-01-91-95	Roller	1	
01/6-3		-01-91-02	Key	1	
01/6-4		-01-91-03	Lever	1	
01/6-5		-01-91-04/1	Pin	1	
01/6-6		-01-91-04/2	Lock	1	
01/6-7	B	-01-91-04/3 /1	Guide	1	
01/6-8	B	-01-91-04/3 /2	Guide	1	
01/6-9	B	-01-91-04/3	Spindle	1	
01/6-10	B	EHN 5231	Retaining ring A16	2	
01/6-11		XPG 40-01-91-04/4	Sleeve	1	
01/6-12		-01-91-04/5	Washer	1	
01/6-13		-01-91-04/6	Fork with sleeve	1	
01/6-13/2		-01-91-04/6 /1	Pipe	1	
01/6-13 /2M	B	EHN 5646-3540-060	Sleeve	2	
01/6-13 /1M		-01-91-04/6 /2	Fork	1	
01/6-14	B	-01-91-04/7	Plunger rod frame	1	
01/6-15		-01-91-04/8	Screw	1	
01/6-16		-01-91-04/9	Screw	1	
01/6-17		-01-91-04/10	Strap	1	
01/6-18	E	-01-91-04/11	Fin	1	
01/6-19		EHN 5400	Cross joint A16m	1	
01/6-20	B	EHN 5511	Cross joint shield V6-8387	1	

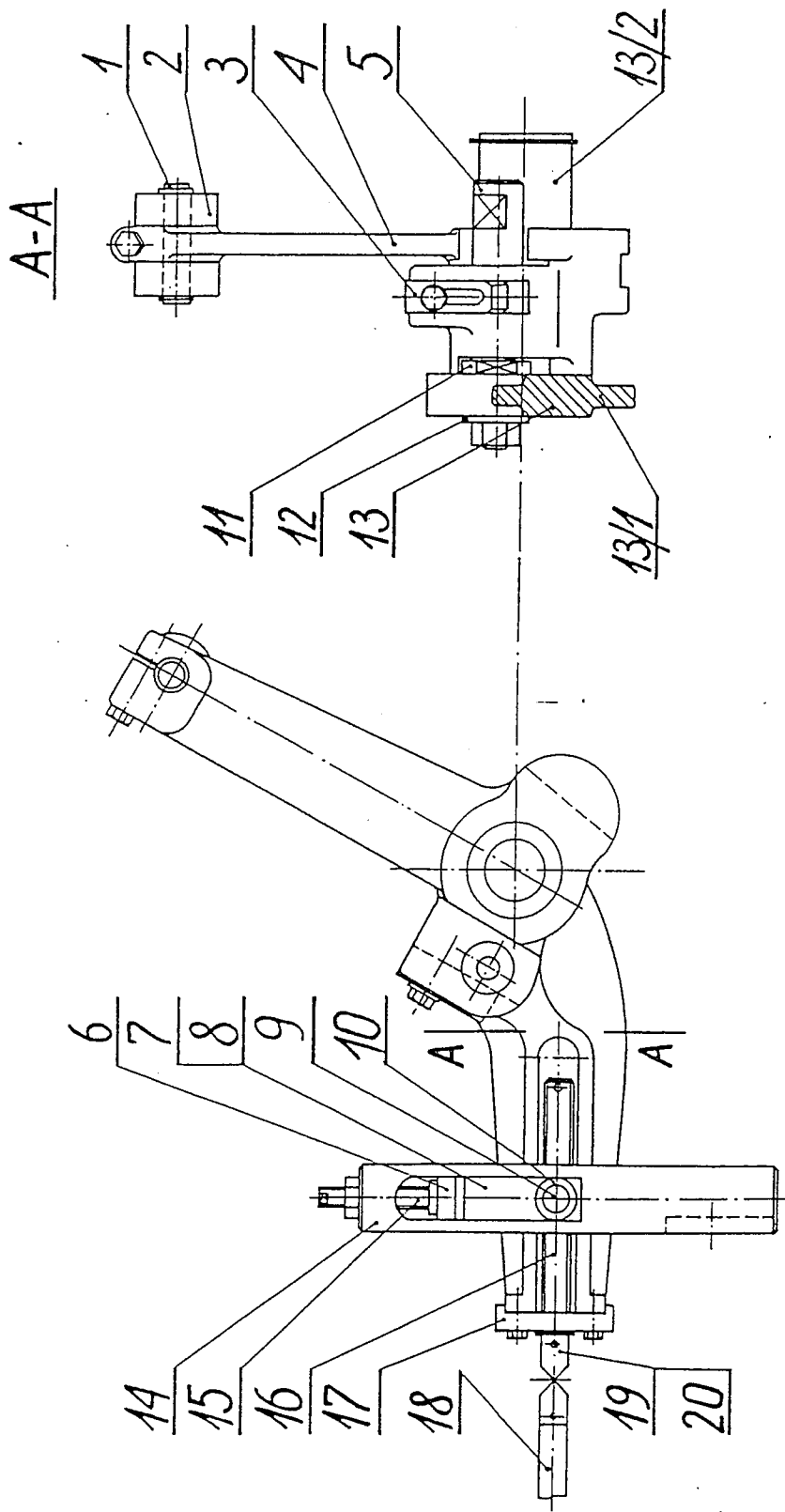

Fig. 01/6

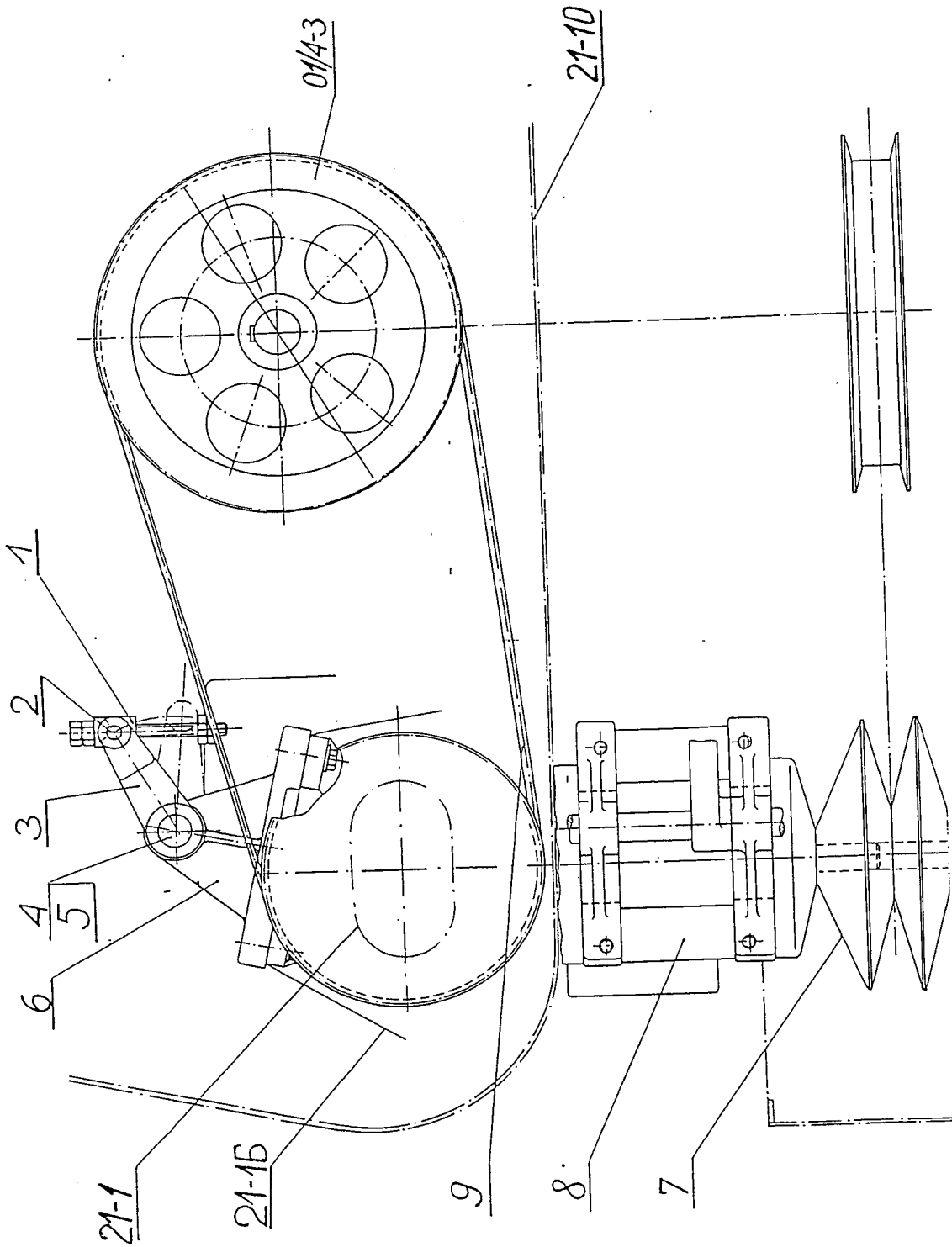

Fig. 01/8



Packing Machine XPG40
Spare parts catalogue

Operating and
Maintenance Instr.

page 22 90 pages

Fig.01/8 Main drive XPG 40-01-101-00

Part No	Group	Drawing No	Part name	Qty	Notes
01/8-1		XPG 40-01-101-01	Cross	1	
01/8-2		-01-101-02	Pin	1	
01/8-3		-01-101-03	Lever	1	
01/8-4		-01-101-05	Shaft	1	
01/8-5		BHN 5132	Retaining ring A30	1	
01/8-6		XPG 40-01-101-06	Stand	1	
01/8-7	B	-01-101-09	Variable-speed transmission	1	
01/8-8		-01-101-10	Electric motor Sg 112-M-6-HL	1	2,2 kW =
01/8-9	A	M1374-311-218-00	Belt B-1800	1	950 r.p.m

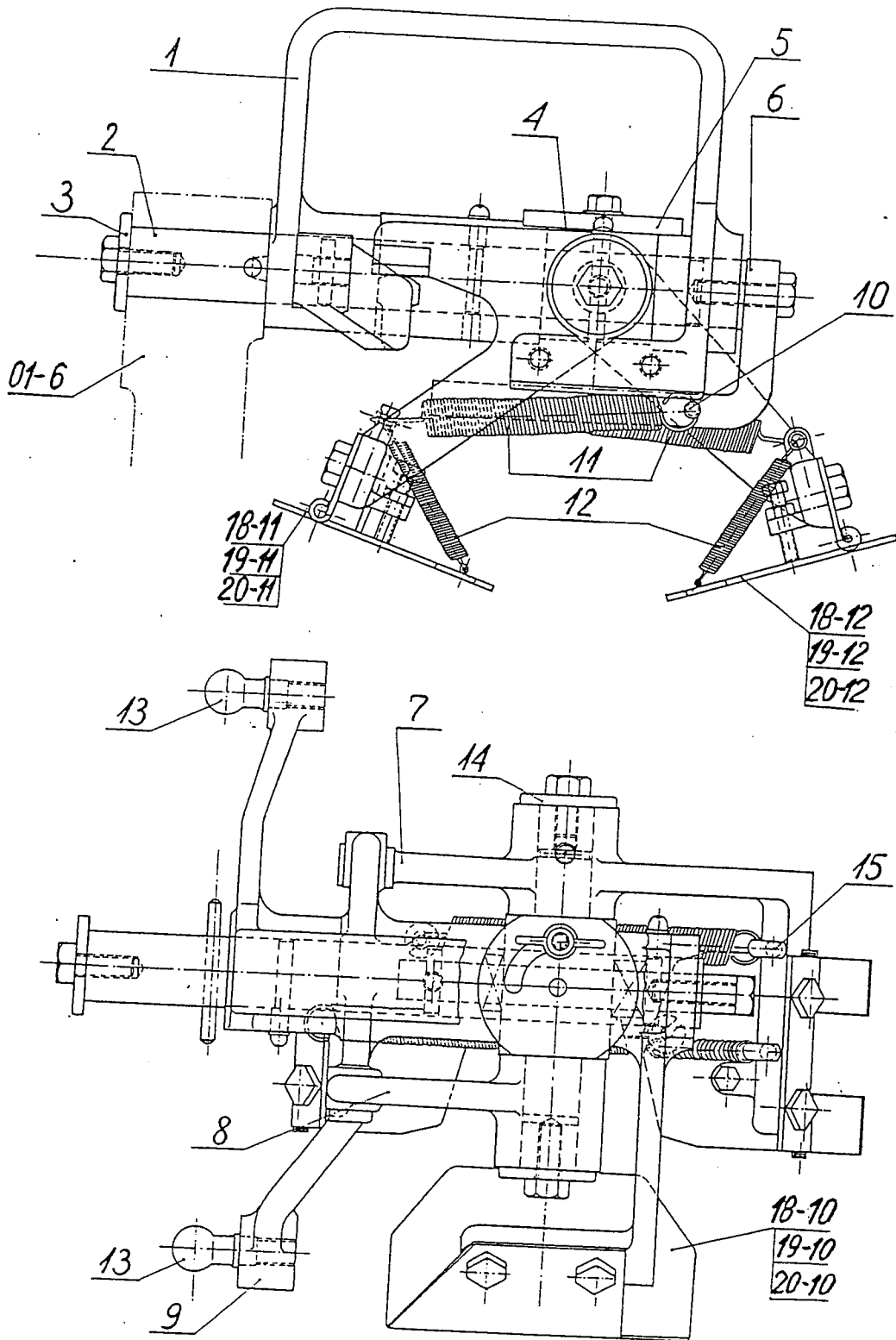

Fig. 02



Packing Machine XPG40
Spare parts catalogue

Operating and
Maintenance Instr.

page 24 90 pages

Fig.02 - Closer XPG 40-02-00-00

Part No	Group	Drawing No	Part name	Qty	Notes
02-1	B	XPG 40-02-00-01	Lever	1	
02-2	E	XPG 40-02-00-02	Shaft	1	
02-3	B	XPG 40-02-00-03	Washer	1	
02-4	B	XPG 40-02-00-04	Slide block	1	
02-5	B	XPG 40-02-00-05	Washer	1	
02-6		XPG 40-02-00-06	Spring holder	1	
02-7	B	XPG 40-02-00-07	Lever	1	
02-8	E	XPG 40-02-00-08	Lever	1	
02-9	B	XPG 40-02-00-09	Lever	1	
02-10		BHN 6211	Catch 6212-061-001	2	
02-11	B	LHN 420	Spring 18x2x95	2	
02-12	B	BHN 420	Spring 7x0,5x45	2	
02-13	B	BHN 5404	Ball pivot A6	2	
02-14		EHN 4232	Washer 5232-008- -004	2	
02-15		EHN 6211	Catch 6211-006-008	4	

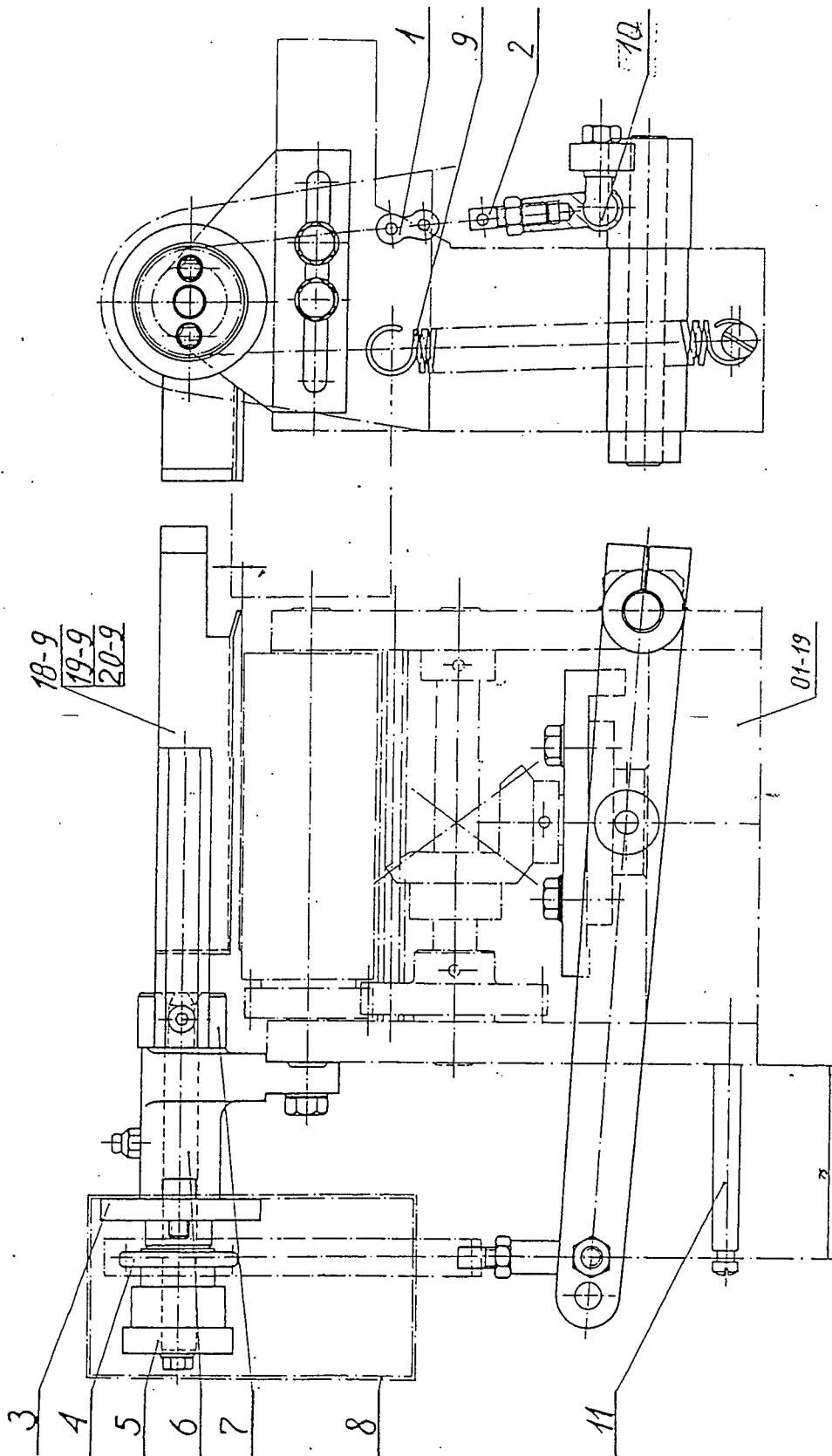

Fig. 03



Packing Machine XPG40
Spare parts catalogue

Operating and
Maintenance Instr.
page 26 90 pages

Fig.03 - Cakes converter XPG 40-03-00-00

Part No	Group	Drawing No	Part name	Qty	Notes
03-1		PN-67/M-84168	Roller chain D8E-20ps	1	
03-2		XPG 40-03-00-02	Catch	1	
03-3		XPG 40-03-00-03	Washer	1	
03-4		XPG 40-03-00-04	Chain wheel	1	
03-5		XPG 40-03-00-05	Ring	1	
03-6		XPG 40-03-06-00	Bracket	1	
03-6/1	B	EHN-5640-131-625E	Sleeve	2	
03-7	B	XPG 40-03-07-00	Shaft complete	1	
03-8		XPG 40-03-00-08	Shield	1	
03-9	A	EHN 420	Spring 18x2x120	1	
03-10	B	EHN 5406	Ball-and-socket joint A13	1	
03-11		EHN 5406	Catch 6212-107-501	1	
-			-		

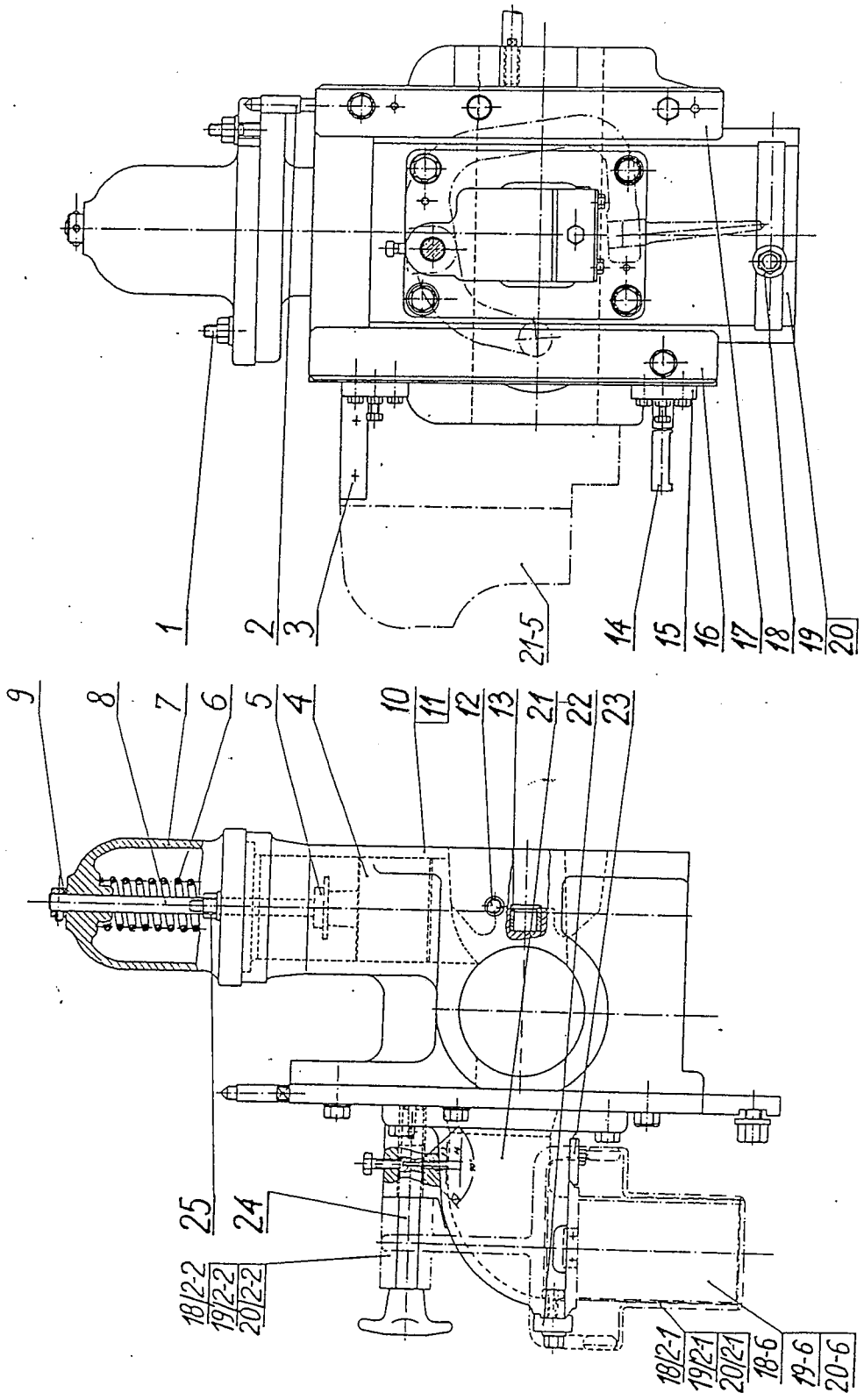

Fig. 04



Fig.04 - Hatcher of worm feeder XFG 40-04-00-00

Part No	Group	Drawing no	Part name	Qty	Notes
04-1		XP1E50-07-34	Stud-bolt	2	
04-2		XFG 40-04-00-02	Pin	1	
04-3		XFG 40-04-00-00	Holder	1	
04-4	E	XFG 40-04-04-01	Compensation plunger	1	
04-5		XP1E50-07-33-04	Washer	1	
04-6/4	E	XFG 40-04-04-03a	Spring	1	
	/b/ E	XP1E50-04-33-05	Spring	1	
	/c/ E	XFG 40-04-04-03c	Spring	1	
04-7		XP1E50-07-33-01	Housing	1	
04-7/1	B	EHN 5640-131-615	Sleeve	1	
04-8	E	XFG 40-04-04-05	Flunger rod	1	
04-9		EHN 5231	Retaining ring A13	1	
04-10		XFG 40-04-00-05	Body	1	Standard form, version without copper
04-12		XFG 40-04-00-10	Pin	1	
04-13		XFG 40-04-00-12	Connector	1	
04-14	A	XFG 40-04-00-11	Sleeve	1	
04-15		XIG 40-04-03-02	Plate	1	
04-16	F	XFG 40-04-00-14	Left strip	1	
04-17	E	XFG 40-04-00-15	Right strip	1	
04-18		XFG 40-04-00-16	Nut	2	
04-19	F	XFG 40-04-17-00	Slider complete	1	Standard form
04-20		XFG 40-04-18-00	Slider complete	1	
04-21		XFG 40-04-19-01	Elbow	1	
04-22		XFG 40-04-19-02	strip	1	
04-23		XFG 40-04-19-03	Strip	1	
04-24	E	XFG 40-04-20-00	Axle complete	1	
04-25		EHN 5205	Nut M10	2	

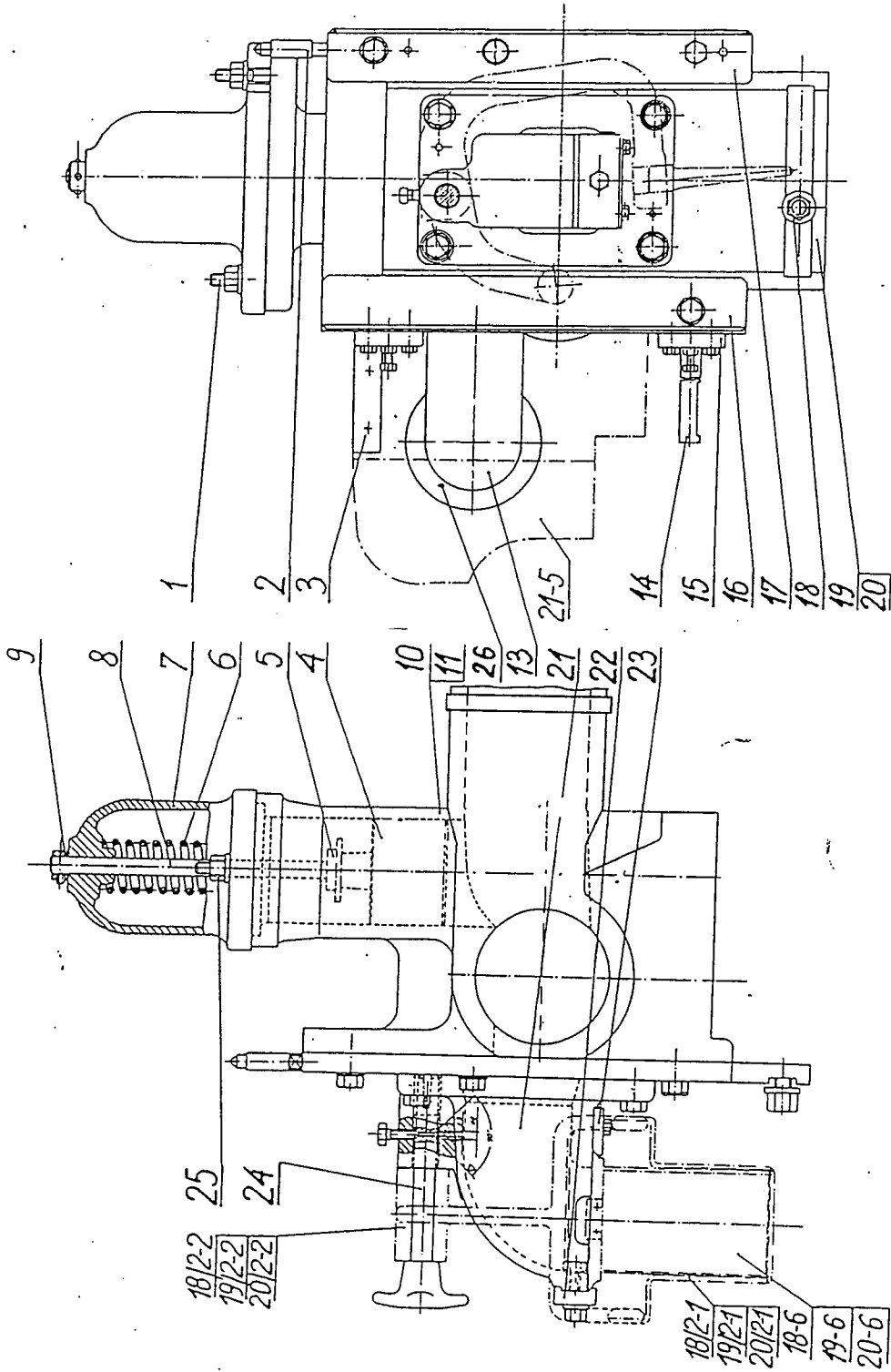

Fig. 05

TREPKO	Packing Machine XPG40			Page 30
GNIEZNO	Spare parts catalogue			Pages 90
Fig.05 Doser with direct connection XPG40-05-00-00				
Part No	Part name	Drawing No	Qty	Notes
05-1	Sud-bolt	XP1E-50-07-34	2	
05-2	Pin	XPG-40-04-00-02	1	
05-3	Holder	XPG-40-04-03-00	1	
05-4	Compensation piston	XPG-40-05-01-02	1	
05-5	Washer	XPG-40-07-33-04	1	
05-6	Spring	XPG-40-05-01-03	1	
05-7	Housing	XPG-40-05-01-01	1	
05-7/1	Sleeve	5640-131-615	1	
05-8	Piston rod	XPG-40-04-04-05	1	
05-9	Retaining ring	BHN 5231	1	
05-10	Housing	XPG-40-05-00-03	1	Standard made
05-11	Housing	XPG-40-05-04-00	1	Wersion without copper
05-13	Elbow	XPG-40-05-07-00	1	
05-14	String	XPG-40-04-00-12	1	
05-15	Plate	XPG-40-04-03-02	1	
05-16	Left strip	XPG-4004-00-14	1	
05-17	Right strip	XPG-40-04-00-15	1	
05-18	Nut	XPG-40-04-00-16	1	
05-19	Slide control set	XPG-40-04-00-17	1	Standard made
05-20	Slide control set	XPG-40-04-18-00	1	Wersion without copper
05-21	Elbow	XPG-40-04-19-01	1	
05-22	Strip	XPG-40-04-19-02	1	

TREPKO	Packing Machine XPG40			Page 31
GNIEZNO	Spare parts catalogue			Pages 90
Fig.05 Doser with direct connection XPG40-05-00-00				
Part No	Part name	Drawing No	Qty	Notes
05-23	Strip	XPG40-04-19-03	1	
05-24	Axle complete	XPG-40-04-20-00	1	
05-25	Nut M10	BHN 5205	2	
05-26	Housing	XPG-40-05-07-00-2	1	

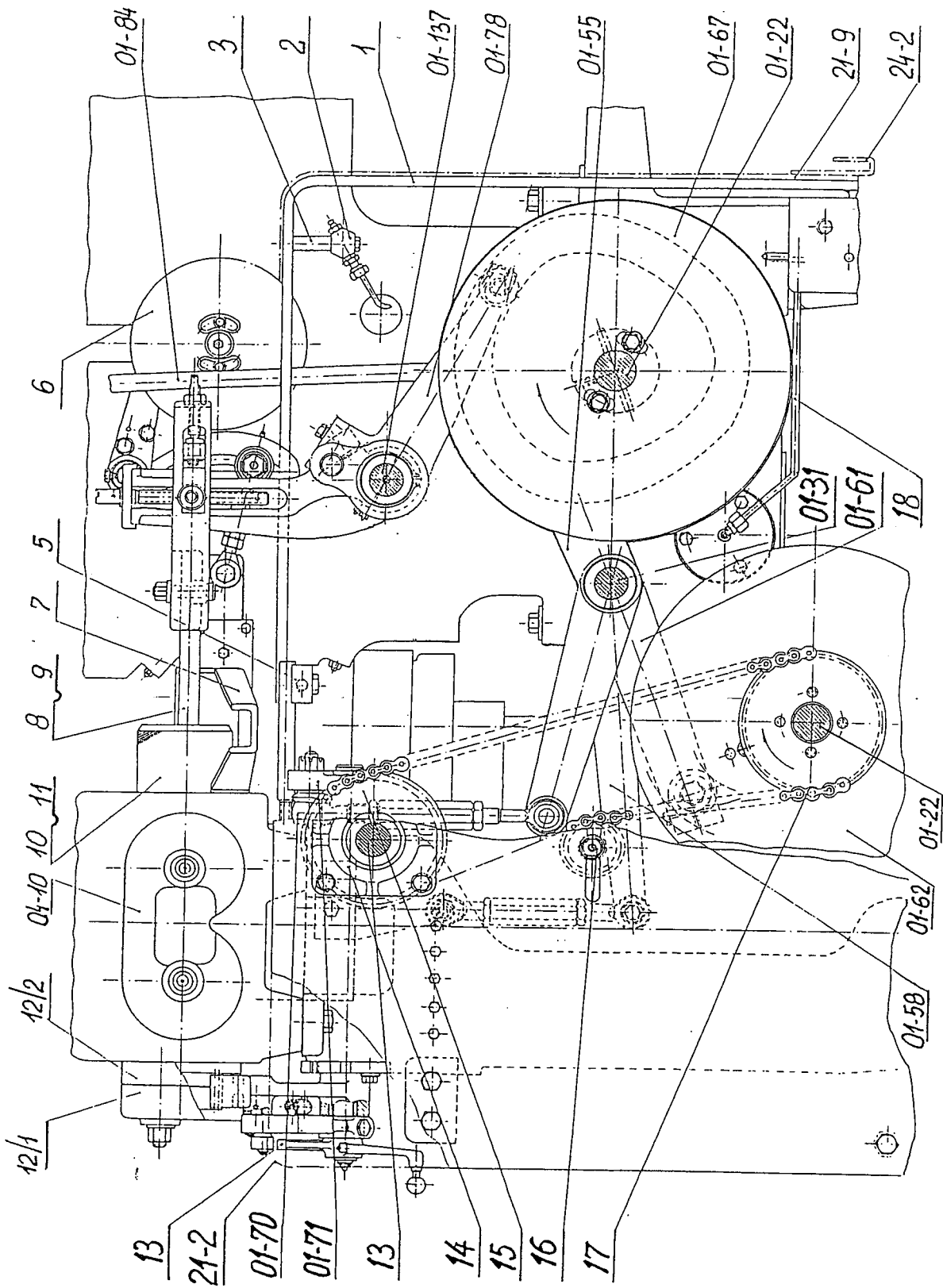

Fig. 07



Packing Machine XPG40
Spare parts catalogue

Operating and
Maintenance Instr.

page 33 90 pages

Fig.07 - Eatcher drive XPG 40-07-00-00

Part No	Group	Drawing No	Part name	Qty	Notes
07-1		XPG 40-07-01-00	Fracket	1	
07-2		XPG 40-07-00-02	Eeam	1	
07-3		XPG 40-07-00-03	Pipe.	1	
07-4		XPG 40-07-00-59	Pin	1	
07-5		XPG 40-07-00-05	Eeam	1	
07-6		XPG 40-07-06-00	Cutoff drive	1	Sub-ass. Drwg.07/1
07-7		XPG 40-07-00-07	Trough	1	
07-8		XPG 40-07-08-00	Plunger complete	1	Sub-ass. Drwg.07/2
07-9		XPG 40-07-09-00	Latching plunger complete	1	Sub-ass. Drwg.07/3
07-10	B	XPG 40-07-10-00	Cylinder complete	1	Standard form
07-11		XPG 40-07-11-00	Cylinder complete	1	Version without copper
07-12/1		XPG 40-07-12-01	Protective cap	1	
07-12/2	E	XPG 40-07-12-02	Holder	1	
07-13	B	XPG 40-07-03-00	Eatcher cut off	1	Sub-ass. Drwg.07/4
07-14			Bearing complete RCI35	1	Import
07-15	E	XPG 40-07-00-15	Chain wheel	1	
07-16	E	XPG 40-07-16-00	Chain stretcher	1	
07-17		PN-67/E-84168	Roller chain 10 E 88 pz	1	
07-18		XPG 40-07-00-18	Pipes	1	

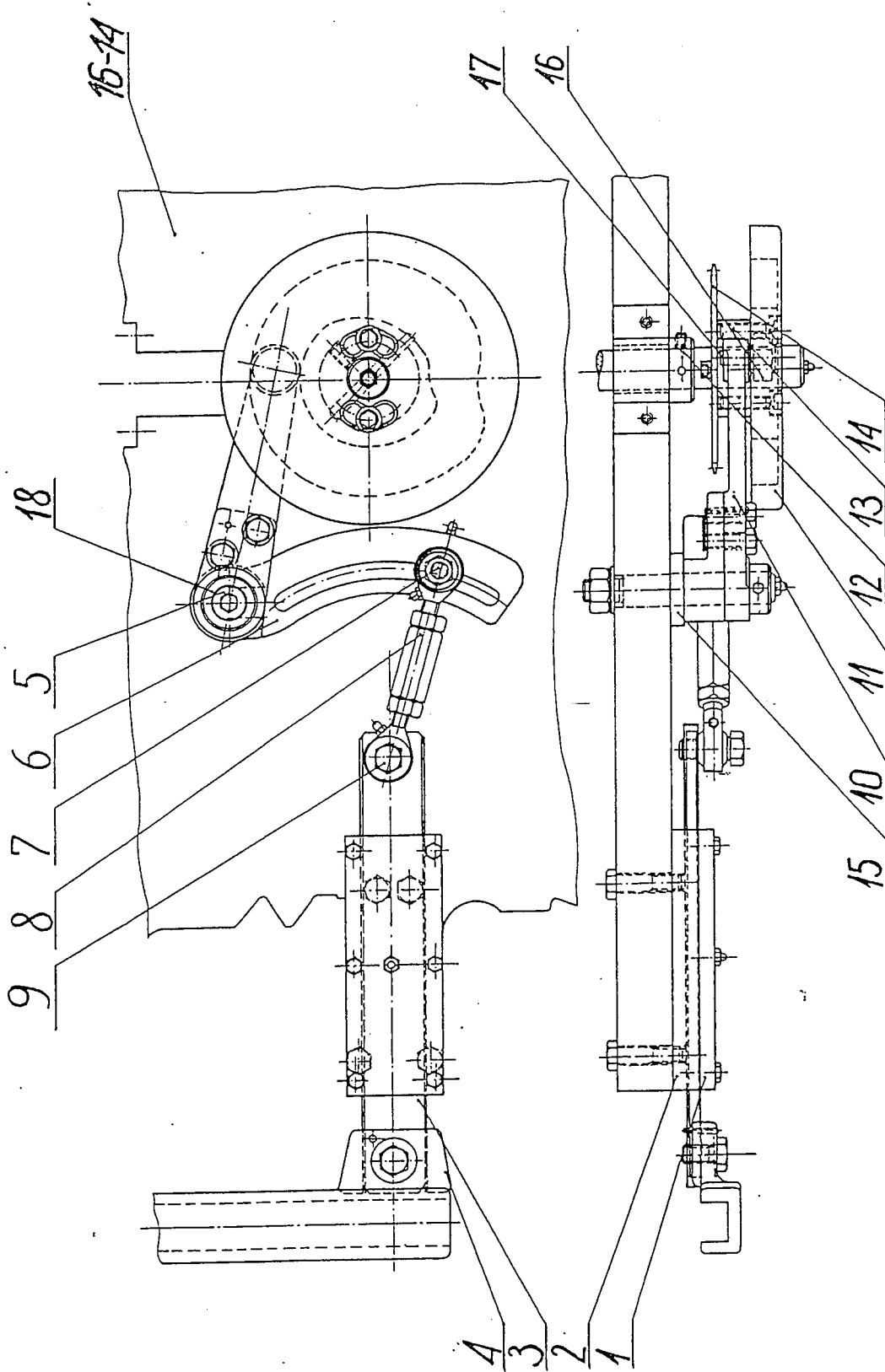

Fig. 07/1



Fig.07/1 - Cutoff drive XPG 40-07-06-00

Part No	Group	Drawing No	Part name	Qty	Notes
07/1-1	B	XPG 40-07-06-11	Cover	1	
07/1-2	B	XPG 40-07-06-12	Guide	1	
07/1-3	E	XPG 40-07-06-13	Strip	1	
07/1-4	E	XPG 40-07-06-14	Roller guide	1	
07/1-5	B	XPG 40-07-06-10	Pin	1	
07/1-6		XPG 40-07-06-09	Lever	1	
07/1-7		XPG 40-07-06-08	Pin complete	1	
07/1-8		XPG 40-07-06-07	Connector	1	
07/1-8/1	B	1999-260-070	Joint SLM12	1	Import
07/1-8/2	E	1999-260-060	Joint SM12	1	Import
07/1-9		XPG 40-07-06-06	Screw	1	
07/1-10		XPG 40-07-06-05	Lever	1	
07/1-11	B	XPG 40-07-06-04	Cam	1	
07/1-12	E	EHN 5231	Retaining ring A25	1	
07/1-13		XPG 40-07-06-01	Hub	1	
07/1-14	E	XPG 40-07-06-03	Chain wheel	1	
07/1-15		EHN 5233	Washer 5233-016- -003	1	
07/1-16	E	EHN 405-1	Roller	1	
07/1-17	E	EHN 405-2	Pin 10x31	1	
07/1-18	E	EHN 5231	Retaining ring A20	1	

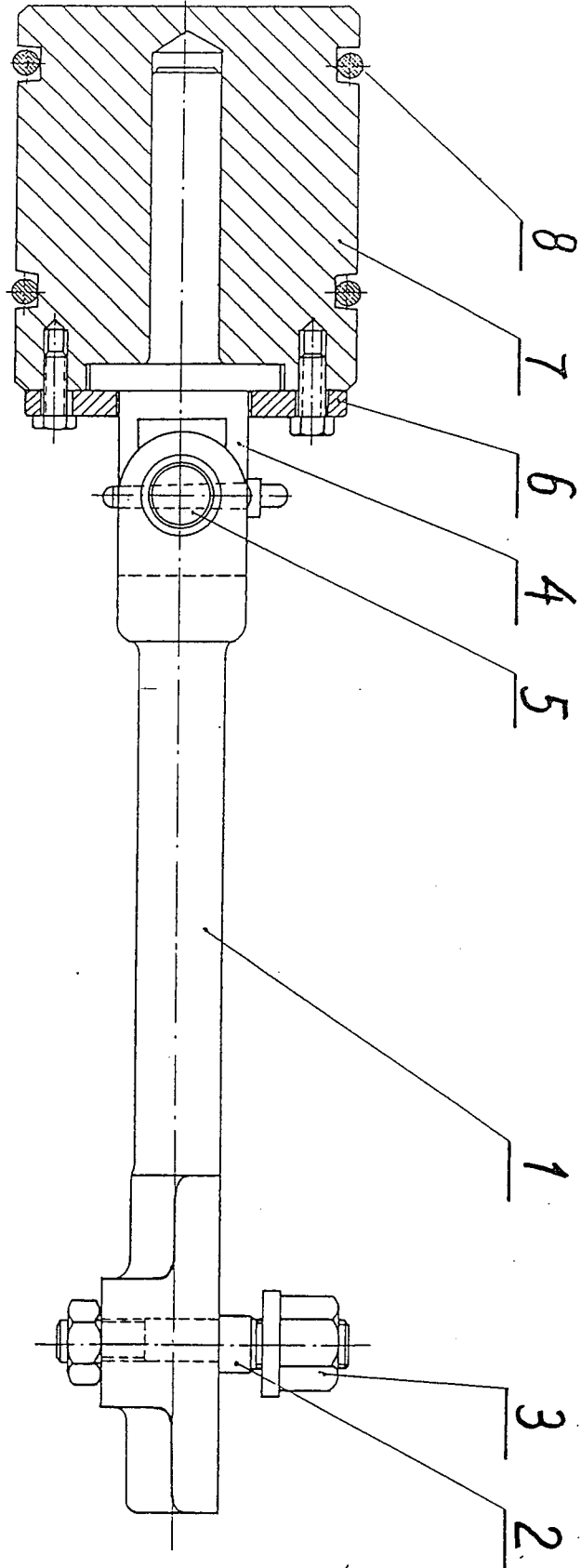

Fig. 07/2



Packing Machine XPG40
Spare parts catalogue

Operating and
Maintenance Instr.

page 37 90 pages

Fig.07/2 - Plunger complete XPG 40-07-08-00 /version without
copper/

Part No	Group	Drawing No	Part name	Qty	Notes
07/2-1		XPG 40-07-08-01/1	Plunger rod	1	
07/2-2		XPG 40-07-08-01/1	Pin	1	
07/2-3		EHN 5205	Nut M12	1	
07/2-4		XPG 40-07-08-02	Pin	1	
07/2-5		XPG 40-07-08-03	Pin	1	
07/2-6		XPG 40-07-08-04	Washer	1	
07/2-7		XPG 40-07-08-05	Plunger	1	
07/2-8		PN-60/M-68961	Seal ring 69,2x x5,07	2	

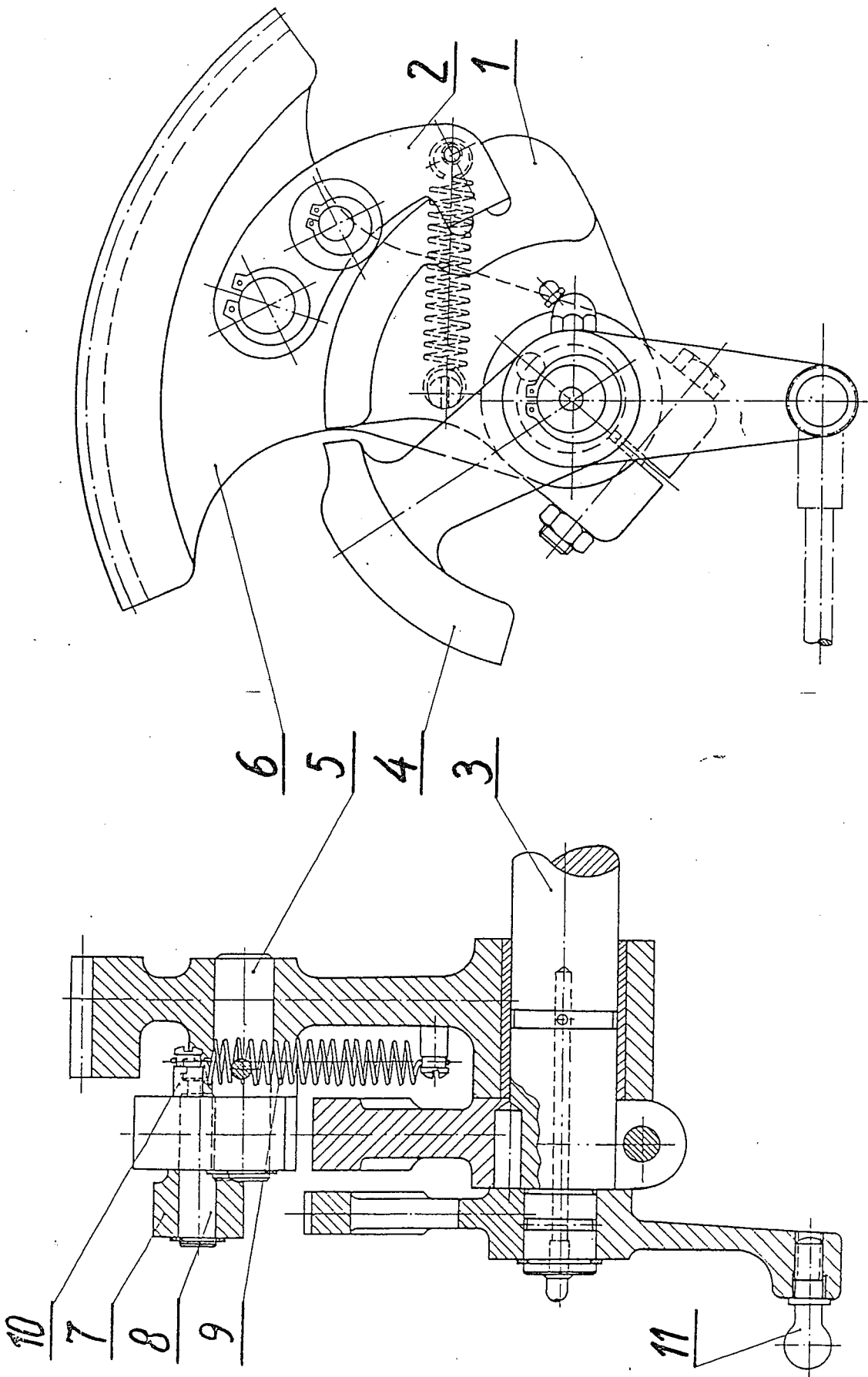

Fig. 07/4



Packing Machine XPG40
Spare parts catalogue

Operating and
Maintenance Instr.

page 39 90 pages

Fig.07/4 - Batcher cut off XPG 40-07-13-00

Part No	Group	Drawing No	Part name	Qty	Notes
07/4-1	B	XPG 40-07-13-01	Driver	1	
07/4-2	B	XPG 40-07-13-02	Latch	1	
07/4-3	B	XPG 40-07-13-03	Shaft	1	
07/4-4		XPG 40-07-13-04	Lever	1	
07/4-4/1	B	BHN 5640-202-520	Sleeve	1	
07/4-5		XPG 40-07-13-05	Pin	1	
07/4-6	B	XPG 40-07-13-06	Rack	1	
07/4-6/1	B	EHN 5640-303-545A	Sleeve	1	
07/4-7		XPG 40-07-13-07	Roller	1	
07/4-8		XPG 40-07-13-08	Pin	1	
07/4-9	A	XPG 40-07-13-09	Spring	1	
07/4-10		EHN 6212	Spring catch	1	
07/4-11	E	EHN 5404	Pivot A13	1	

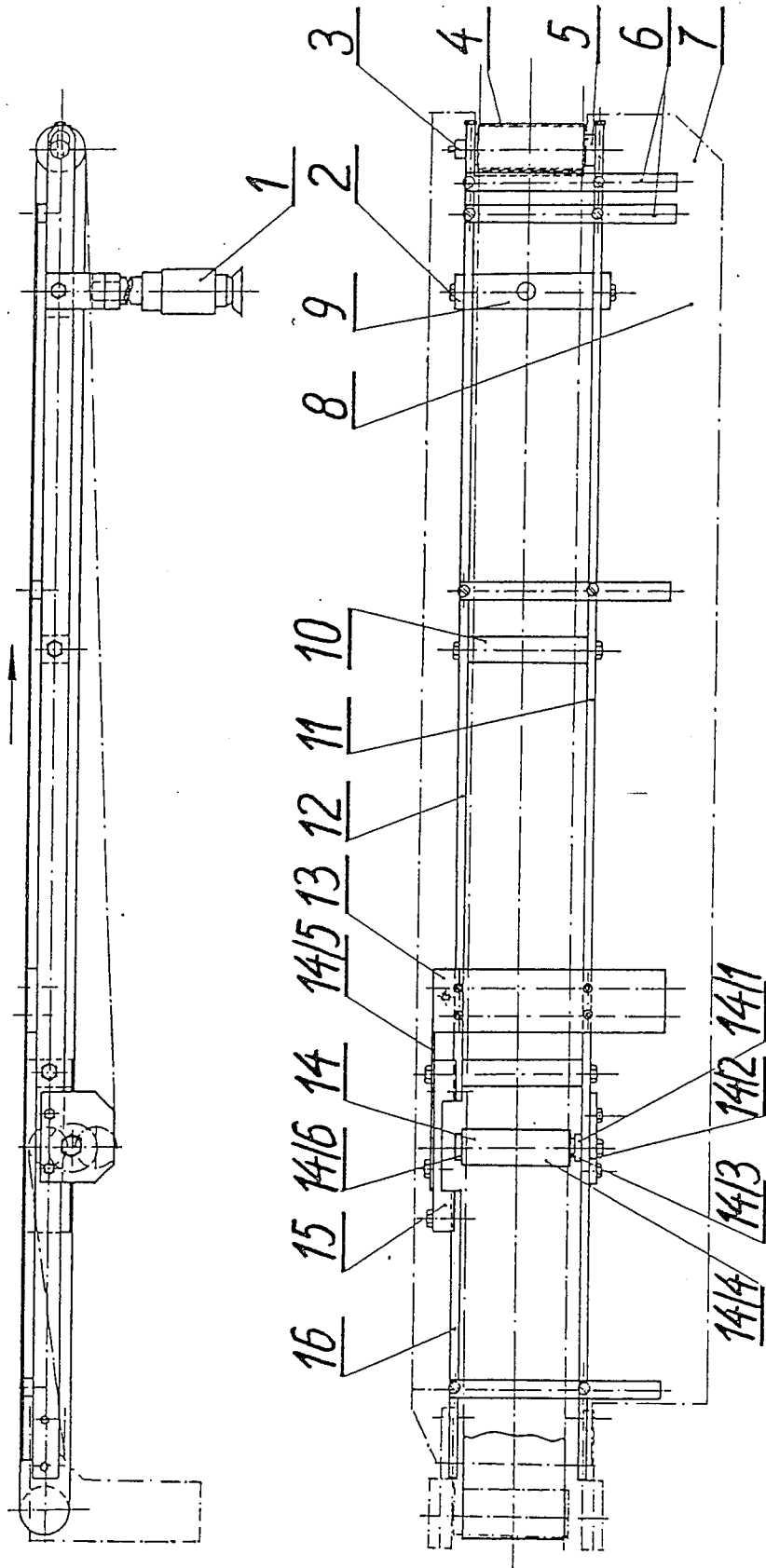

Fig. 08



Packing Machine XPG40
Spare parts catalogue

Operating and
Maintenance Instr.

page 41

90 pages

Fig.08 - Conveyor XPG 40-08-00-00

Part No	Group	Drawing No	Part name	Qty	Notes
08-1		XPG 40-08-01-00	Leg complete	1	
08-2		XPG 40-08-00-02	Strap	1	
08-3	B	XPG 40-08-00-03	Axle	1	
08-4		XPG 40-08-00-04	Band	1	Import
08-5		XPG 40-08-05-00	Roller	1	
08-5/1	B	BHN 5640-202-530	Sleeve	2	
08-6		XPG 40-08-00-06	Strip	4	
08-7		XPG 40-08-00-07	Sheet	1	
08-8		XPG 40-08-00-08	Sheet	1	
08-9		XPG 40-08-00-09	Holder	1	
08-10		XPG 40-08-00-10	Eam	2	
08-11		XPG 40-08-00-11	Spar	1	
08-12		XPG 40-08-00-12	Spar	1	
08-13		XPG 40-08-00-13	Strip	1	
08-14		XPG 40-08-14-00	Band stretcher	1	
08-14/1		XPG 40-08-14-01	Holder complete	1	
08-14/2		XPG 40-08-14-02	Holder	1	
08-14/3	B	XPG 40-08-14-03	Axle	2	
08-14/4		XPG 40-08-14-04	Roller	2	
08-14/4/1	E	BHN 5640-163-015	Sleeve	4	
08-14/5		XPG 40-08-14-05	Sheet	1	
08-14/6		XPG 40-08-14-06	Holder	1	
08-15		XPG 40-08-00-15	Strip	1	
08-16		XPG 40-08-00-16	Spar	1	

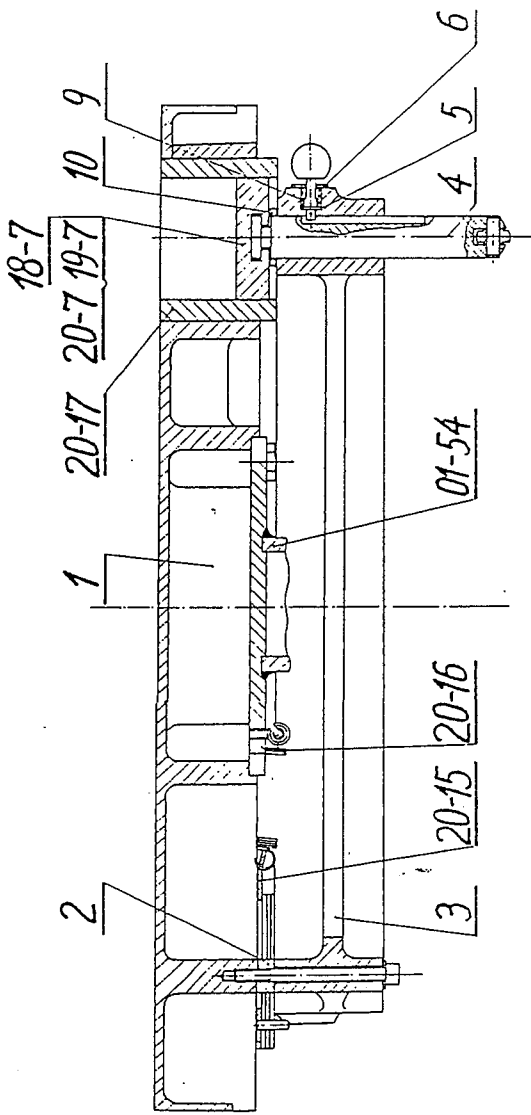

A-B

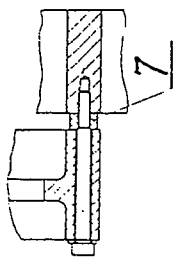

C-D

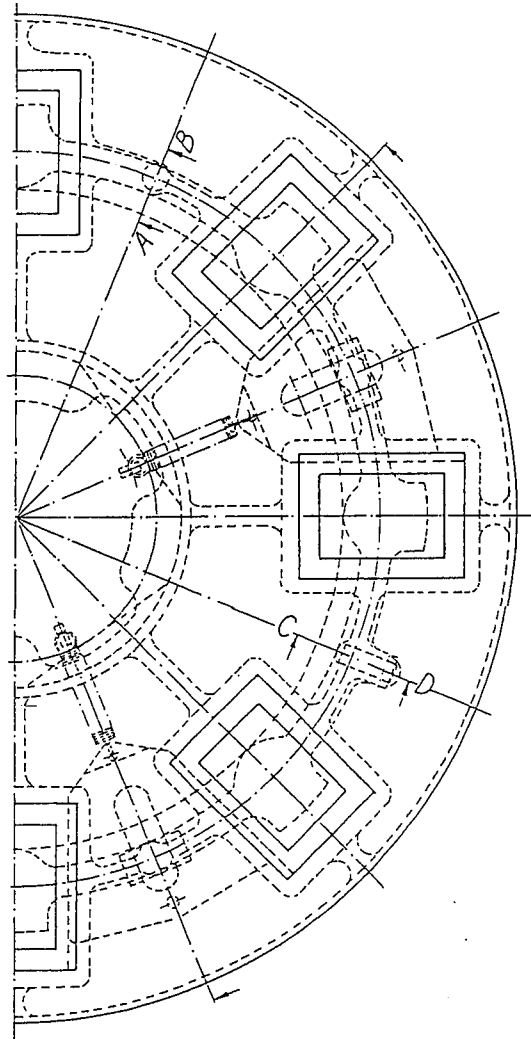
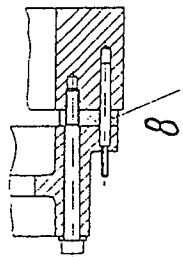

Fig. 10



Packing Machine XPG40
Spare parts catalogue

Operating and
Maintenance Instr.

page 43 . 90 pages

Fig.10 - Revolving table XPG 40-10-00-00

Part No	Group	Drawing No	Part name	Qty	Notes
10-1		XPG 40-10-00-74	Revolving table	1	
10-2		XPG 40-10-00-02	Washer	4	
10-3		XPG 40-10-00-03	Ring	1	
10-4	B	XPG 40-10-04-00	Pusher complete	8	
10-5		XPG 40-10-00-05	Fin	8	
10-6		XPG 40-10-00-06	Plate	8	
10-7		XPG 40-10-00-07	Plate	2	
10-8		XPG 40-10-00-08	Spacer	2	
10-9	B	EHN 412	Spring 10x1x15	8	
10-10	E	PK-64/M-73093	Seal ring 25x5	8	

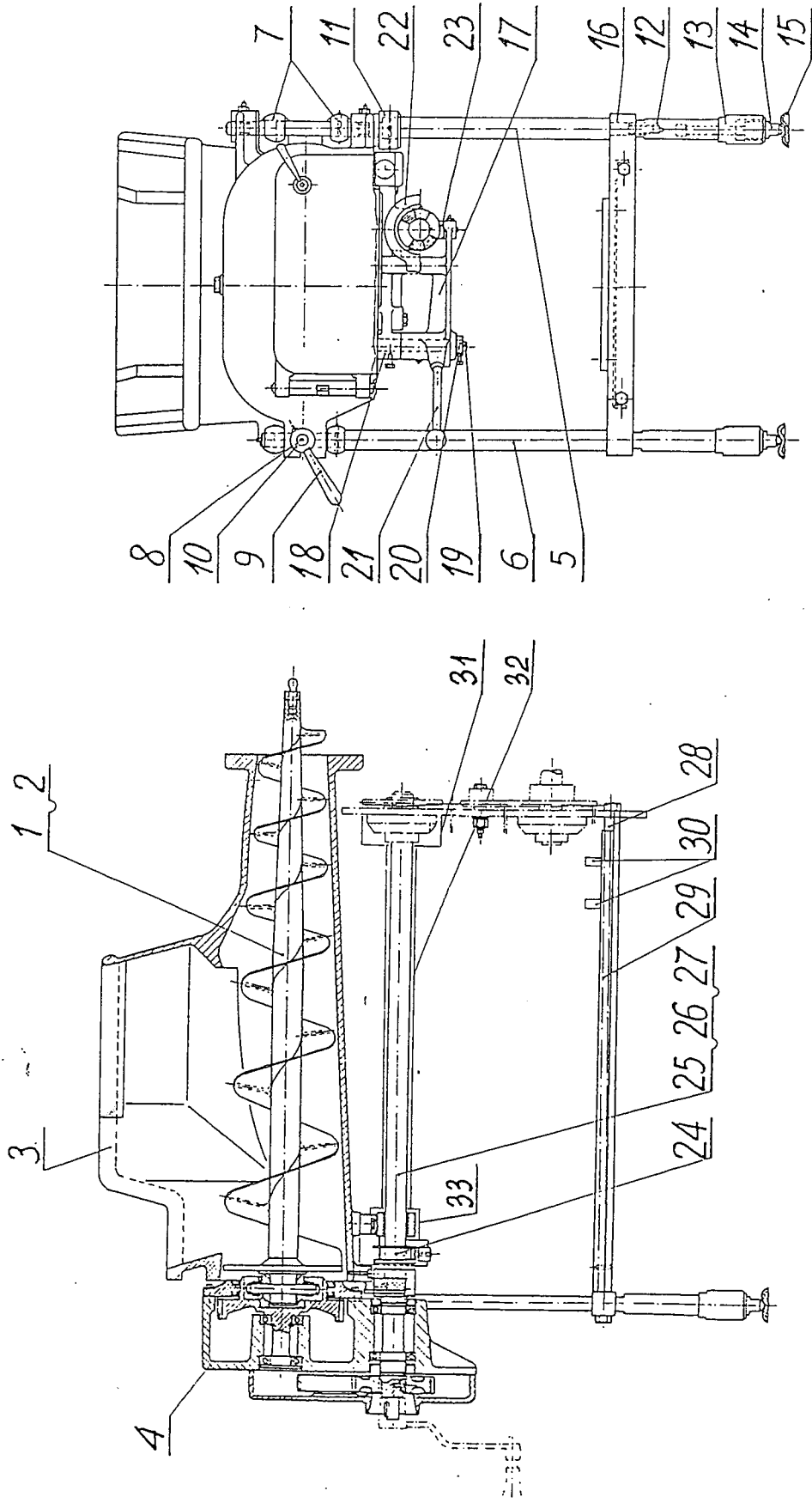

Fig. 13



Packing Machine XPG40
Spare parts catalogue

Operating and
Maintenance Instr.

page 45 90 pages

Fig.13 - Worm feeder XPG 40-13-CO-00

Part No	Group	Drawing No	Part name	Qty	Notes
13-1		XP1E 50-06-01-00	Laevo-rotary worm	1	
13-2		XP1E 50-06-02-00	Dextrose worm	1	
13-2/1	B	XP1E 50-06-01-05	Worm pin	2	
13-3		XPG 40-13-55-00-3	Worm chute	1	
13-4		XP1E 50-06-04-00	Worm drive	1	Sub-ass. Drwg.13/1
13-5		XPG 40-13-00-05	Right bracket	1	
13-6		XPG 40-13-00-06	Left bracket	1	
13-7		XP1E 50-06-07	Connecting element	4	
13-8		XP1E 50-06-08	Hinged pin	1	
13-9		PK-57/M-56155	Clamp grip D 160	1	
13-10		XP1E 50-06-10	Spacer ring	1	
13-11		XP1E 50-06-12	Retaining ring	1	
13-12		XPG 40-13-00-13	Intermediate nut	2	
13-13		XPE 50-01-100	Body nut	2	
13-14		XPE 50-01-101	Adjusting screw	2	
13-15		XPE 50-01-102	Foot	2	
13-16		XP1E 50-06-17	Carrying beam	1	
13-17		XP1E 50-06-18-02	Connecting lever	1	
13-18		XP1E 50-06-18-01	Body	1	
13-19		XP1E 50-06-18-03	Pin	1	
13-20		EHN 5231	Retaining ring A20	1	
13-21		XP1E 50-06-19	Lever rod	1	
13-22		XP1E 50-06-21	Coupling shield	1	
13-23	B	XP1E 50-06-22-00	Coupling slide block	1	
13-24	E	XP1E 50-06-23	Claw coupling	1	
13-25		XPG 40-13-00-24	Shaft	1	
13-26		XPG 40-13-00-26	Key 8x7x25	1	
13-27		XP1E 50-06-25	Key 8x7x40	1	
13-28		XPG 40-13-00-27	Connector	1	
13-29		XPG 40-13-33-01	Base complete	1	
13-30		XP1E 50-06-32-02	Strip	2	

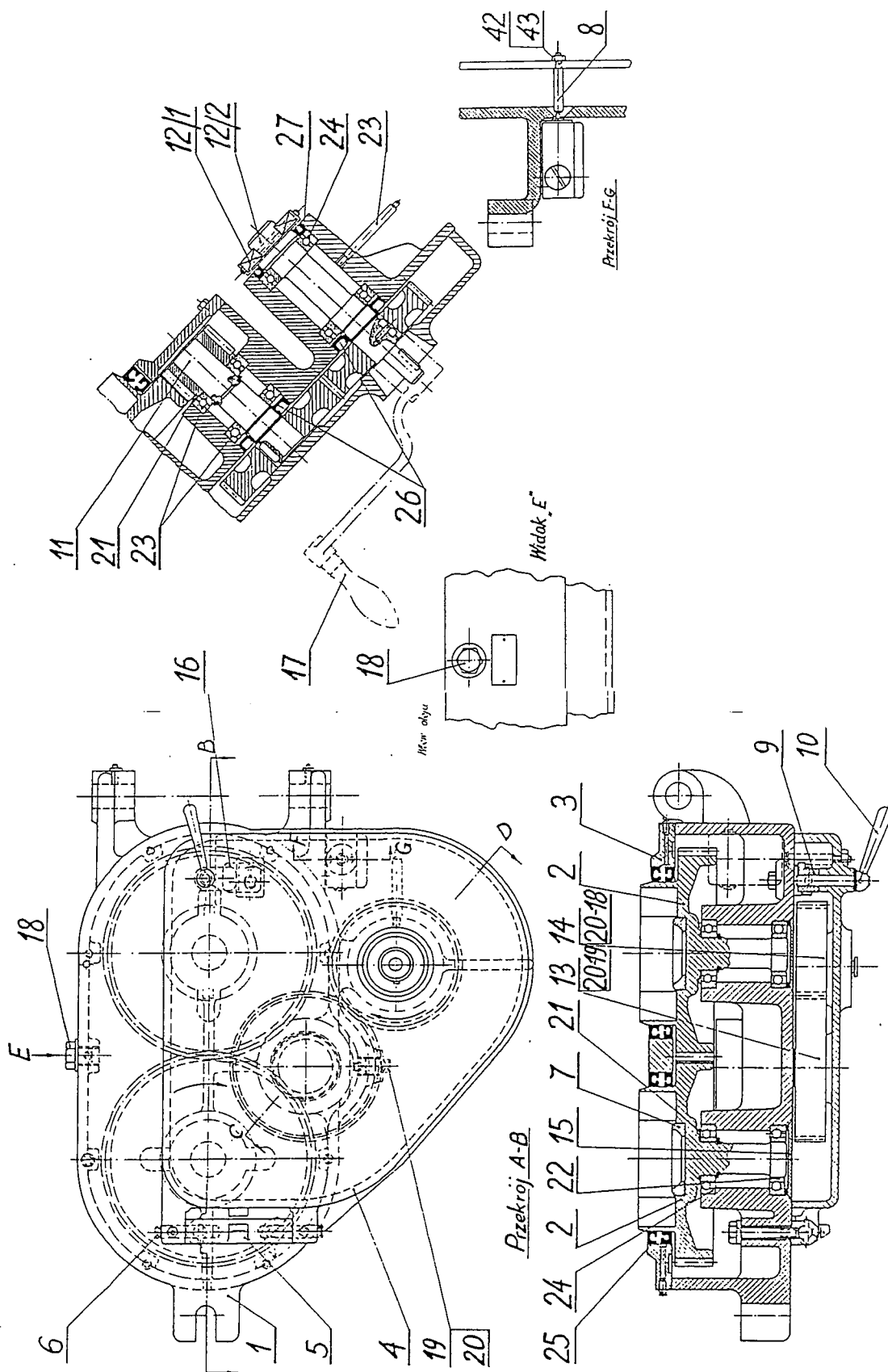

Fig. 13/1



Packing Machine XPG40
Spare parts catalogue

Operating and
Maintenance Instr.
page 47 90 pages

Fig.13/1 - Transporting worms drive XP1E 50-06-04-00

Part No	Group	Drawing No	Part name	Qty	Notes
13/1-1		XP1E 50-06-04-01	Gear box	1	
13/1-2	B	XP6 40-13-57-00	Gear of the worm	2	
13/1-3		XP1E 50-06-04-03	Gear box cover	1	
13/1-4		XP1E 50-06-04-04	Protection cover	1	
13/1-5		XP1E 50-06-04-05	Jointed element	1	
13/1-6		XP1E 50-06-04-06	Pin	2	
13/1-7	B	XP1E 50-06-04-07	Ball bearing bush	2	
13/1-8		XP1E 50-06-04-08	Limit pin	1	
13/1-9		XP1E 50-06-04-09	Clamp	1	
13/1-10		XP1E 50-06-04-10	Pin with grip	1	
13/1-11	B	XP1E 50-06-04-11	Gear with shaft	1	
13/1-12/1	B	XP1E 50-06-04-12-01	Shaft	1	
13/1-12/2	B	XP1E 50-06-04-12-02	Claw coupling	1	
13/1-13	B	XP1E 50-06-04-13	Change gear	1	
13/1-14	B	XP1E 50-06-04-14	Change gear	1	
13/1-15		XP1E 50-06-04-15	Cover	1	
13/1-16		XP1E 50-06-04-16	Lever clamp	1	
13/1-17		XP1E 50-06-04-21	Positioned crank	1	
13/1-18		XP1E 50-06-04-25	Plug R1-Z with vent	1	
13/1-19		ZN-53/NPM	Plug R1/2"		
13/1-20		N60/c1454	Washer 21	1	
13/1-21		EHN 5505	Ring "Nilos" 6207 A	3	Import
13/1-22		XP1E 50-06-04-33	Washer SB70	2	
13/1-23		XP1E 50-06-04-36	Greasing pipe 5820-000-001	1	
13/1-24			Ball bearing 6207	8	
13/1-25		PN-66/M-86960	Seal ring E150x x180x15	4	
13/1-26		PN-66/M-86960	Seal ring A35x72x x7	2	
13/1-27		PN-66/M-86960	Seal ring A50x72x x8	1	

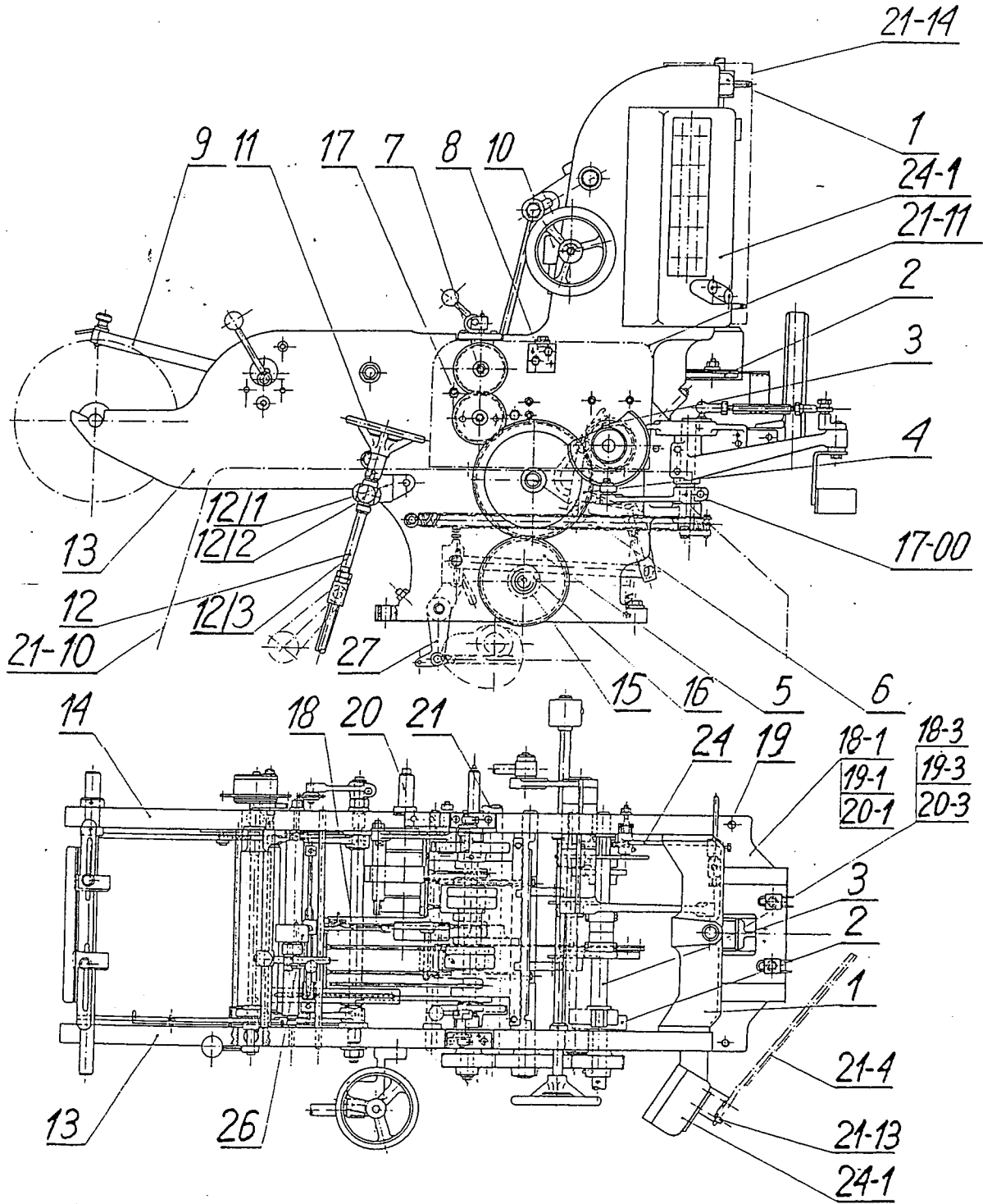

Fig. 16



Packing Machine XPG40
Spare parts catalogue

Operating and
Maintenance Instr.

page 49 90 pages

Fig.16 Paper unit XFG 40-16-00-00

Part No	Group	Drawing No	Part name	Qty	Notes
16-1		XPG 40-16-01-00	Forming punch drive	1	Sub-ass. Drwg.16/1
16-2		XPG 40-16-02-00	Fender	1	Sub-ass. Drwg.16/2
16-3		XPG 40-16-03-00	Feeding rollers	1	Sub-ass. Drwg.16/3
16-4	E	XPG 40-16-04-00	Gear z=79	1	
16-4/1	B	EHN 5640-253-0308	Sleeve	1	
16-5	E	XPG 40-16-05-00	Gear z=61	1	
16-5	E	BHN 5640-253-0308	Sleeve	2	
16-6	B	XPG 40-16-00-06	Pin	1	
16-7		XPG 40-16-07-00	Transport roller	1	Sub-ass. Drwg.16/4
16-8		XPG 40-16-00-08	Angle steel	1	
16-9		XPG 40-16-09-00	Paper feeder	1	Sub-ass. Drwg.16/5
16-10		XPG 40-16-10-00	Weight regulator	1	Sub-ass. Drwg.16/7
16-11		XPG 40-16-11-00	Ratio change hand-wheel	1	
16-12		XPG 40-16-12-00	Ratio change drive	1	
16-12/1		XPG 40-16-12-01	Bearing	1	
16-12/2		XPG 40-16-12-02	Pin	1	
16-12/3		XPG 40-16-12-04	Spindle	1	
16-13		XPG 40-16-13-00	Side wall left	1	
16-13/1	E	XPG 40-16-13-02	Sleeve	1	
16-13/2	E	BHN 5640-253-035A	Sleeve	2	
16-13/3	E	BHN 5640-202-535A	Sleeve	3	
16-13/4	B	EHN 5640-162-015	Sleeve	2	
16-13/5	B	EHN 5640-101-315	Sleeve	2	
16-13/6	B	EHN 5640-404-535A	Sleeve	1	
16-14		XPG 40-16-14-00	Side wall right	1	
16-14/1	E	XPG 40-16-13-02	Sleeve	1	
16-14/2	E	EHN 5640-253-035A	Sleeve	3	
16-14/3	E	EHN 5640-101-315	Sleeve	2	
16-14/4	E	EHN 5640-404-535A	Sleeve	1	
16-14/5	B	BHN 5640-131-615	Sleeve	1	
16-14/6	E	EHN 5640-162-015	Sleeve	2	



Packing Machine XPG40
Spare parts catalogue

Operating and
Maintenance Instr.

page 50

90 pages

Fig.16 Paper unit XPG 40-16-00-00

Part No	Group	Drawing No	Part name	Qty	Notes
16-14/7	B	BHN 5640-202-535A	Sleeve	3	
16-15	B	XPG 40-16-00-15	Pin	1	
16-16		XPG 40-16-00-16	Spacer washer	2	
16-17		XPG 40-10-00-17	Protective pin	2	
16-18		XPG 40-16-18-00	Mechanical centring device	1	Sub-ass. Drwg.16/8
16-19		XPG 40-16-19-00	Bolt complete	1	
16-20		XPG 40-16-00-20	Sleeve	1	
16-21		XPG 40-16-21-00	Knife drive	1	Sub-ass. Drwg.16/9
16-24		XPG 40-16-24-00	Feeding sensor	1	Sub-ass. Drwg.16/10
16-26		XPG 40-16-26-00	Brake, date stamp	1	Sub-ass. Drwg.16/11
16-27		XPG 40-16-27-00	Paper pusher	1	Sub-ass. Drwg.16/13

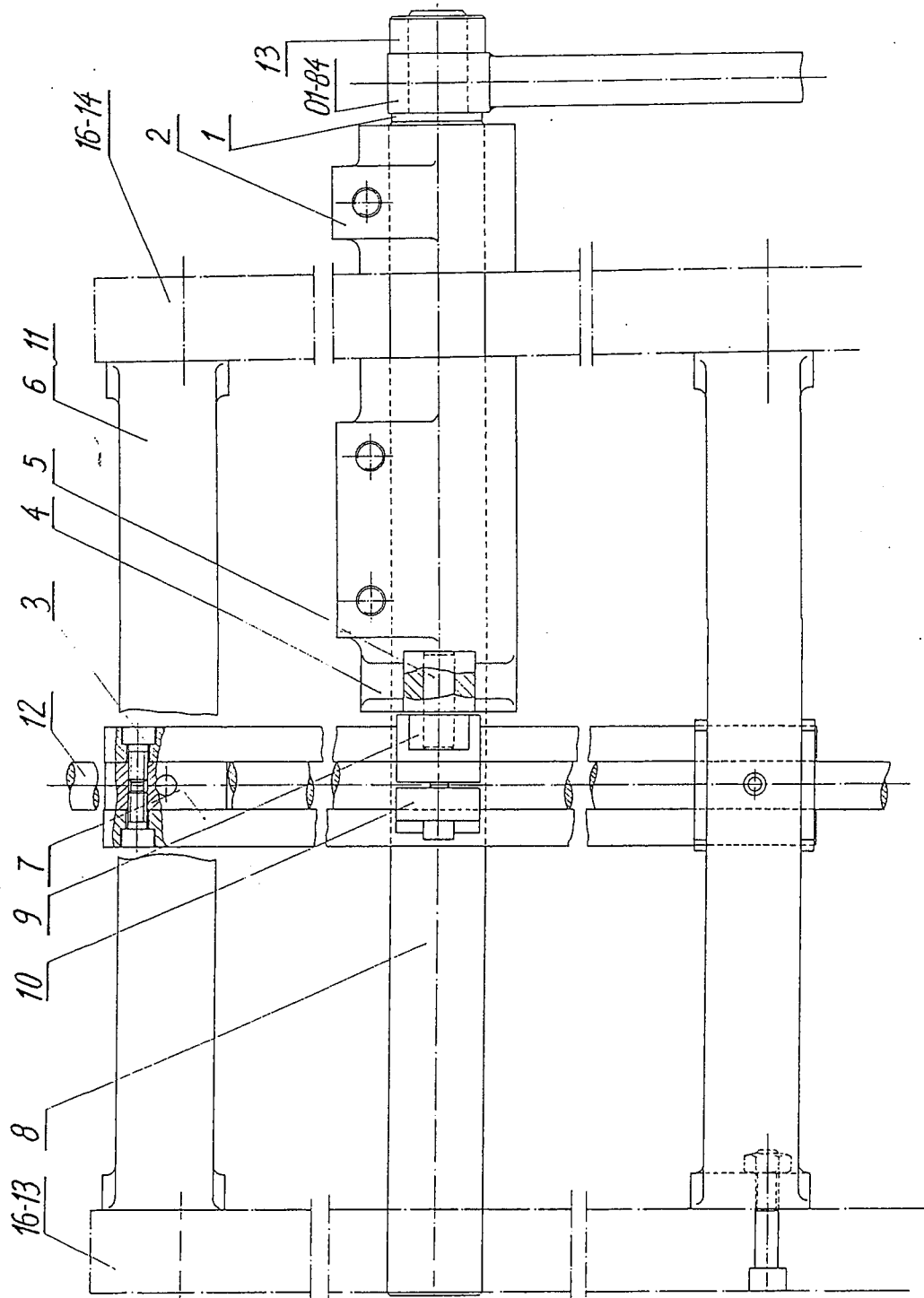

Fig. 16/1



Packing Machine XPG40
Spare parts catalogue

Operating and
Maintenance Instr.

page 58 90 pages

Fig.16/4 - Transport rollers XPG 40-16-07-00

Part No	Group	Drawing No	Part name	Qty	Notes
16/4-1		XPG 40-16-07-01	Ring complete	1	
16/4-2	E	XPG 40-16-07-02	Gear z=34	1	
16/4-3	E	XPG 40-16-07-03	Gear z=34	1	
16/4-4		XPG 40-16-07-04	Elevator complete	1	
16/4-4/1		BHN 5640-253-040A	Sleeve	2	
16/4-5		XPG 40-16-07-05	Roll	2	
16/4-6		XPG 40-16-07-06	Axle	1	
16/4-7		XPG 40-16-07-07	Lever	1	
16/4-8	E	XPG 40-16-07-08/3	Shaft	1	
16/4-9		XPG 40-16-07-08/1	Roller	2	
16/4-10		XPG 40-16-07-08/2	Sleeve	1	
16/4-11		XPG 40-16-07-09	Pressure pad compl.	1	
16/4-12	B	XPG 40-16-07-10	Shaft	1	
16/4-13		XPG 40-16-07-11	Roller complete	1	
16/4-13/1	E	XPG 40-16-07-11/2	Roll	2	
16/4-14	B	BHN 5231	Retaining ring A25	2	

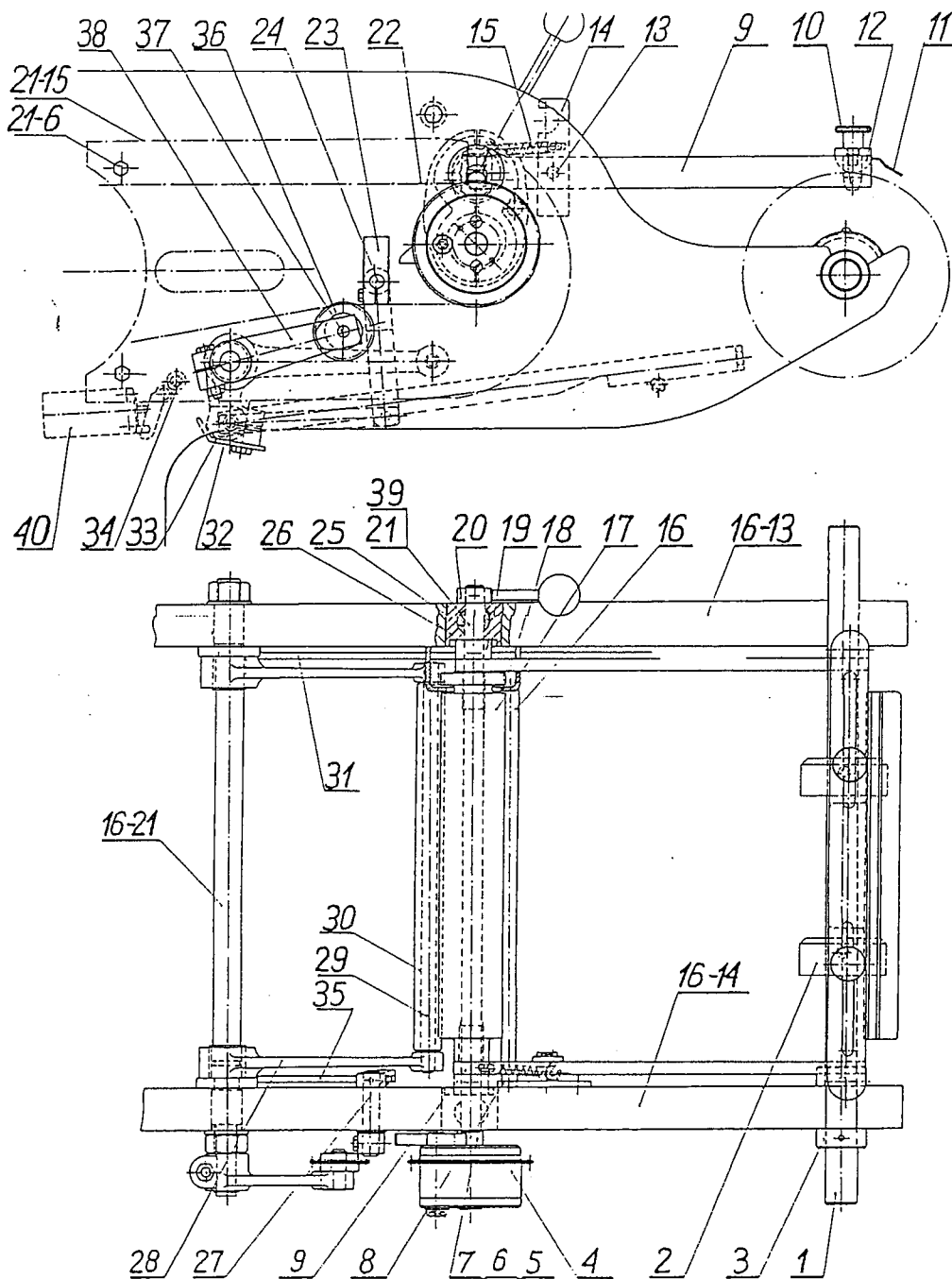

Fig. 16/5



Packing Machine XPG40
Spare parts catalogue

Operating and
Maintenance Instr.

page 60 90 pages

Fig.16/5 Paper feeder XPG 40-16-09-00

Part No	Group	Drawing No	Part name	Qty	Notes
16/5-1	E	XPG 40-16-09-01/1	Shaft	1	
16/5-2	E	XPG 40-16-09-01/2	Centring ring	2	
16/5-3	B	EHN 5231	Retaining ring A25	2	
16/5-4	E	XPG 40-16-09-02	Coupling complete	1	Sub-ass. Drwg.16/6
16/5-5	F	XPG 40-16-09-03/1	Shaft	1	
16/5-6		XPG 40-16-09-03/2	Gear z=25	1	
16/5-7	F	XPG 40-16-09-03/3	Roller	1	
16/5-7/1		EHN 5640-202-520	Sleeve	2	
16/5-8		XPG 40-16-09-04	Holder	1	
16/5-9		XPG 40-16-09-05/1	Yoke	1	
16/5-10		XPG 40-16-09-05/2	Pin	2	
16/5-11		XPG 40-16-09-05/3	Sheet	1	
16/5-12	E	XPG 40-16-09-05/4	Brake strip	1	
16/5-13		XPG 40-16-09-05/5	Pin	1	
16/5-14		XPG 40-16-09-05/6	Latch	1	
16/5-15		EHN 420	Spring 10x1x35	1	
16/5-16		XPG 40-16-09-06	Axle	1	
16/5-17		XPG 40-16-09-07	Roller complete	1	
16/5-17/1	B	EHN 5640-162-030A	Sleeve	2	
16/5-18		XPG 40-16-09-08	Shield	1	
16/5-19	E	XPG 40-16-09-09	Ring	2	
16/5-20		XPG 40-16-09-10	Lever	1	
16/5-21		XPG 40-16-09-11	Axle	1	
16/5-22		PN-67/L-S4168	Roller chain 081 90 p.s.	1	
16/5-23	E	XPG 40-16-09-13	Stop	1	
16/5-24		XPG 40-16-09-14	Pin	1	
16/5-25	B	XPG 40-16-09-15	Bracket	2	
16/5-26	E	XPG 40-16-09-16	Sleeve	2	
16/5-27		XPG 40-16-09-17	Lever complete	1	
16/5-28		XPG 40-16-09-18/1	Lever	2	
16/5-28/1	E	EHN 5640-253-025A	Sleeve	2	
16/5-29		XPG 40-16-09-18/2	Cross bar	1	
16/5-30		XPG 40-16-09-18/3	Roller complete	1	
16/5-30A	B	XPG 40-16-09-18/3/1	Sleeve	2	



Packing Machine XFG40
Spare parts catalogue

Operating and
Maintenance Instr.
page 61 90 pages

Fig.16/5 Paper feeder XPG 40-16-09-00

Part No	Group	Drawing No	Part name	Qty	Notes
16/5-31		XPG 40-16-09-18/4	Connector	1	
16/5-32		XPG 40-16-09-18/5	Ear	1	
16/5-33		XPG 40-16-09-18/6	Flate	1	
16/5-34		XPG 40-16-09-18/7	Stop	1	
16/5-35		XPG 40-16-09-19	Flat	1	
16/5-36		XPG 40-16-09-20	Chain wheel compl.	1	
16/5-36/1	B	EHN 5640-101-315A	Sleeve	1	
16/5-37	B	EHN 405.2	Pin 10x31	1	
16/5-38		XPG 40-16-09-21	Lever	1	
16/5-39	A	EHN 421	Spring 12,5x1,5x30	2	
16/5-40		FAEL Zabkowice	Microswitch 83.759-1	1	

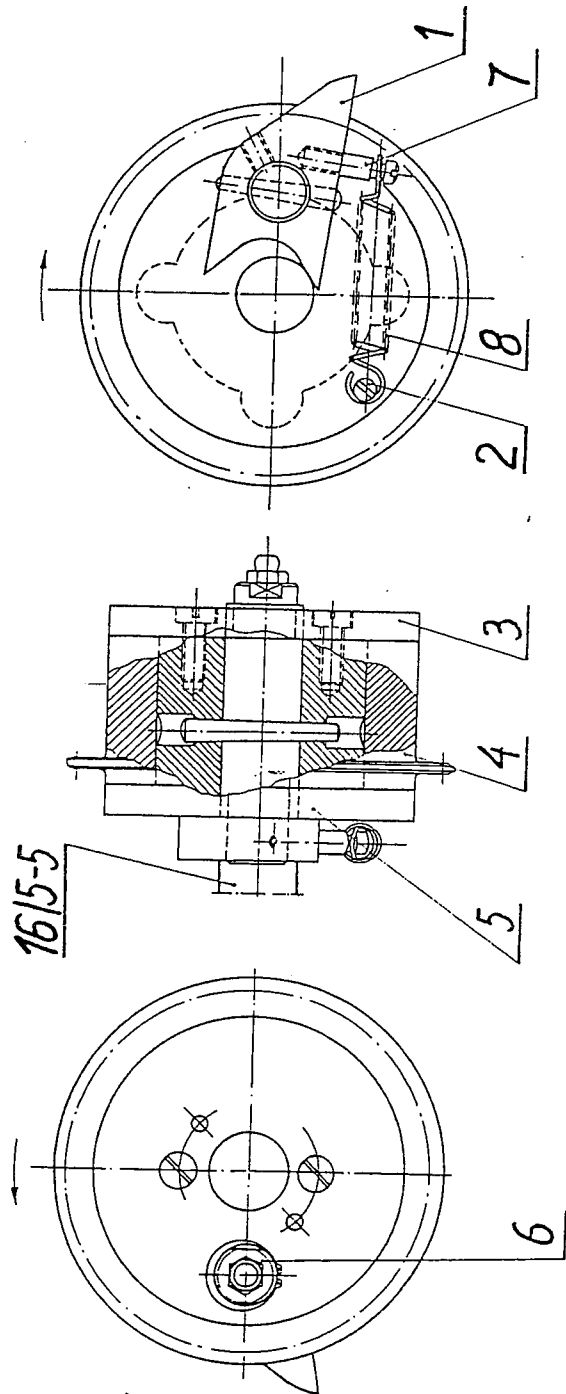

Fig. 16/6



Packing Machine XFG40
Spare parts catalogue

Operating and
Maintenance Instr.

page 63 90 pages

Fig.16/6 - Coupling complete XFG 40-16-09-02

Part No	Group	Drawing No	Part name	Qty	Notes
16/6-1	B	XPG 40-16-09-02/1	Latch	1	
16/6-2		XPG 40-16-09-02/2	Spring catch	1	
16/6-3		XPG 40-16-09-02/3	Cover	1	
16/6-4		XPG 40-16-09-02/4	Chain wheel	1	
16/6-5		XPG 40-16-09-02/5	Sleeve	1	
16/6-6	A	XPG 40-16-09-02/6	Pin	1	
16/6-7		BHN 6212	Catch 6212-061-001	1	
16/6-8	A	BHN 420	Spring 10x1x60	1	

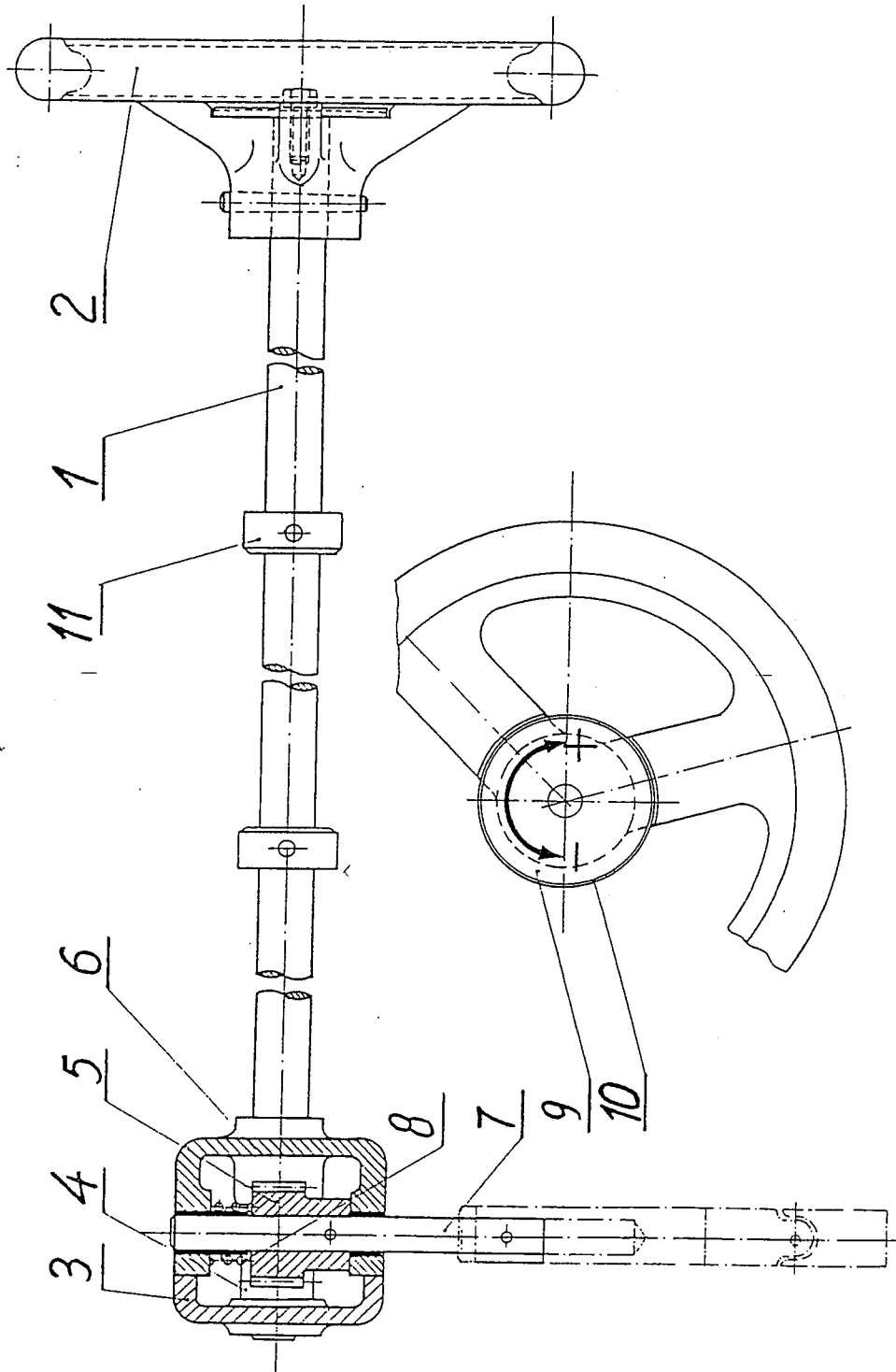

Fig. 16/7



Packing Machine XFG40
Spare parts catalogue

Operating and
Maintenance Instr.
page **65** ~~90~~ pages

Fig.16/7 - Weight setting device XPG 40-16-10-00

Part No	Group	Drawing No	Part name	Qty	Notes
16/7-1		XPG 40-16-10-01	Shaft	1	
16/7-2		XPE 50-02-90-02	Hand wheel	1	
16/7-3		XPE 50-02-90-04	Eody cover	1	
16/7-4		XPE 50-02-90-05	Gear	1	
16/7-5		XPE 50-02-90-06	Gear	1	
16/7-6		XPE 50-02-90-03	Eody	1	
16/7-7	B	XPG 40-16-10-07	Guide complete	1	
16/7-8		BHN 421	Spring 19x2,5x13	1	
16/7-9		XPE 50-01-140	Plate	1	
16/7-10		XPG 40-16-10-10	Washer	1	
16/7-11		EHN 5231	Retaining ring A16	2	

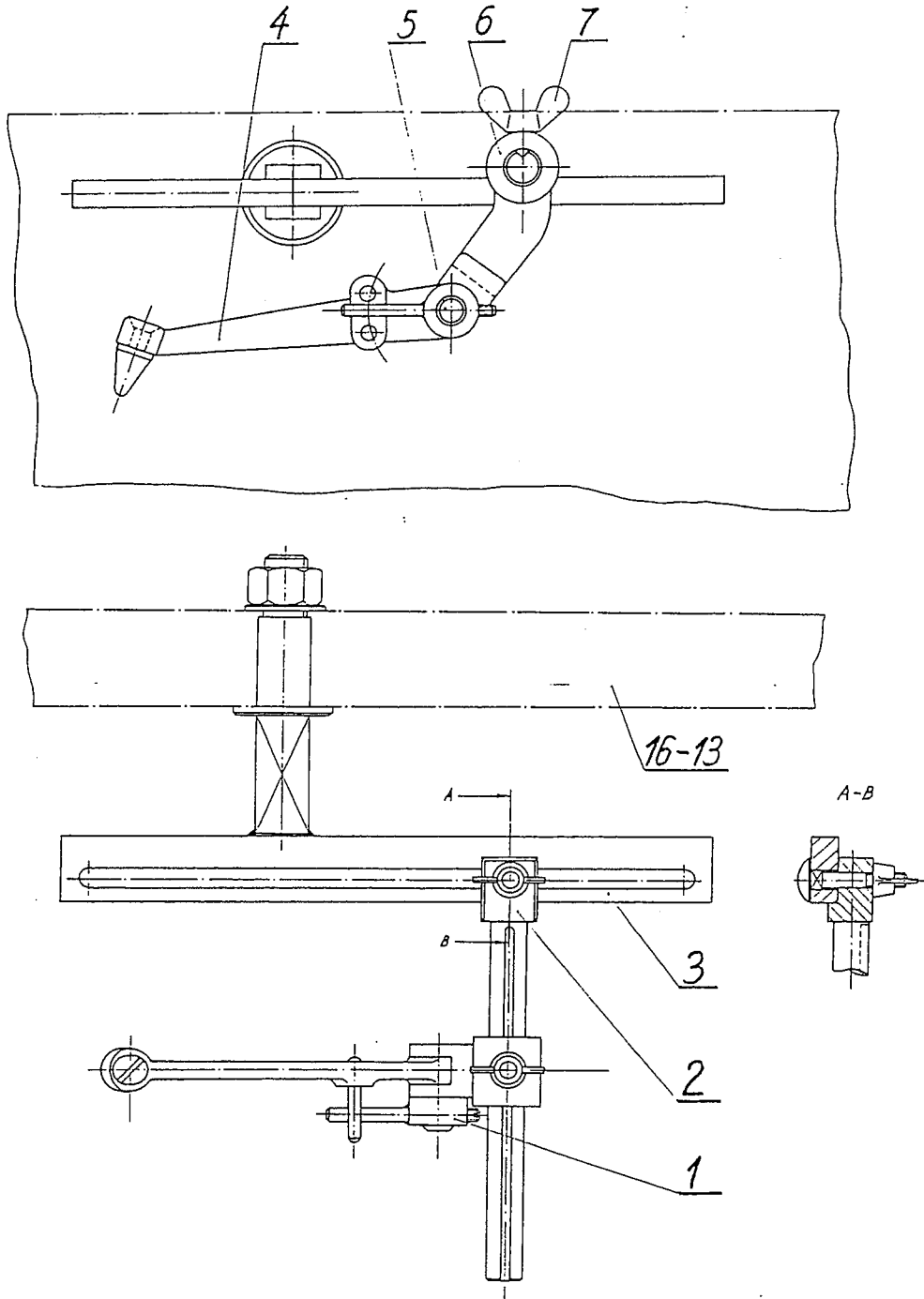

Fig. 16/8



Packing Machine XPG40
Spare parts catalogue

Operating and
Maintenance Instr.
page **67** **90** pages

Fig.16/8 Mechanical centring device XPG 40-16-18-00

Part No	Group	Drawing No	Part name	Qty	Notes
16/8-1		XPG 40-16-18-01	Stop	1	
16/8-2		XPG 40-16-18-02	Pin	1	
16/8-3		XPG 40-16-18-03	Guide	1	
16/8-4		XPG 40-16-18-04	Finger complete	1	
16/8-5		XPG 40-16-18-05	Axle	1	
16/8-6		XPG 40-16-18-06	Holder	1	
16/8-7		BHN 5074	Bolt 5074-10-001	1	

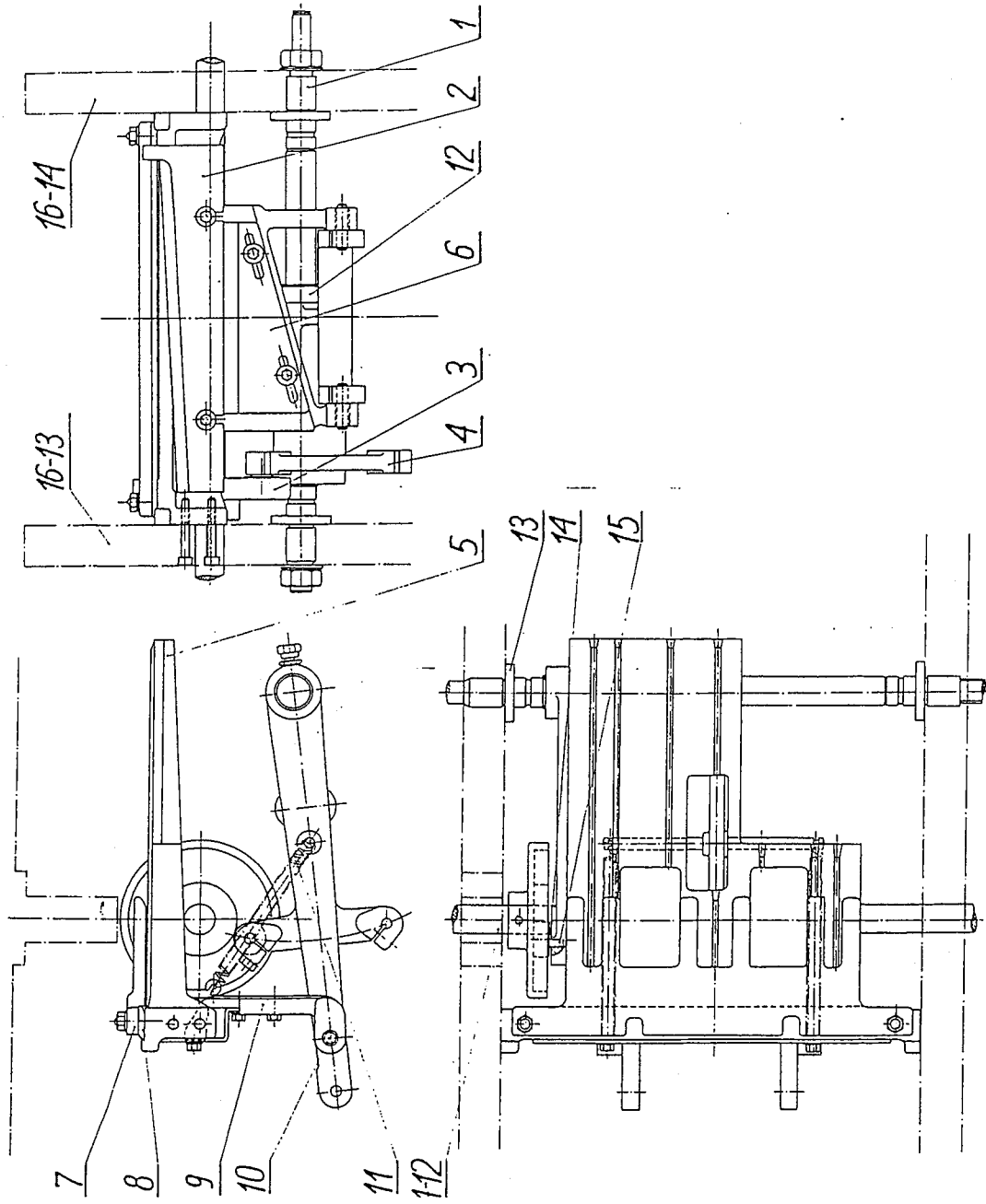

Fig. 16/9



Packing Machine XPG40
Spare parts catalogue

Operating and
Maintenance Instr.

page 69 90 pages

Fig.16/9 Knife drive XPG 40-16-21-00

Part No	Group	Drawing No	Part name	Qty	Notes
16/9-1	E	XPG 40-16-21-01	Axle	1	
16/9-2	A	XPE 50-02-127	Knife	1	
16/9-3	E	XPG 40-16-21-03	Cam	1	
16/9-4		XPG 40-16-21-04	Lever	1	
16/9-4/1		BHN 5640-253-030E	Sleeve	2	
16/9-4/2	B	BHN 5640-162-020E	Sleeve	2	
16/9-5		XPG 40-16-21-05	Guide	1	
16/9-6		XPG 40-16-21-06	Set block	1	
16/9-7		XPG 40-16-21-07	Guide	1	
16/9-8	A	XPE 50-03-25	Lower knife	1	
16/9-9		XPG 40-16-21-09	Gripper	1	
16/9-9/1	B	BHN 5640-101-320	Sleeve	1	
16/9-10		XPG 40-16-21-10	Pin	2	
16/9-11	A	BHN 420	Spring 13x1,5x150	2	
16/9-12	E	EHN 5231	Retaining ring A25	1	
16/9-13		EHN 5233	Washer 5233-020-005	2	
16/9-14	A	EHN 405.1	Roll 30	1	
16/9-15	A	EHN 405.2	Pin 10x35	1	

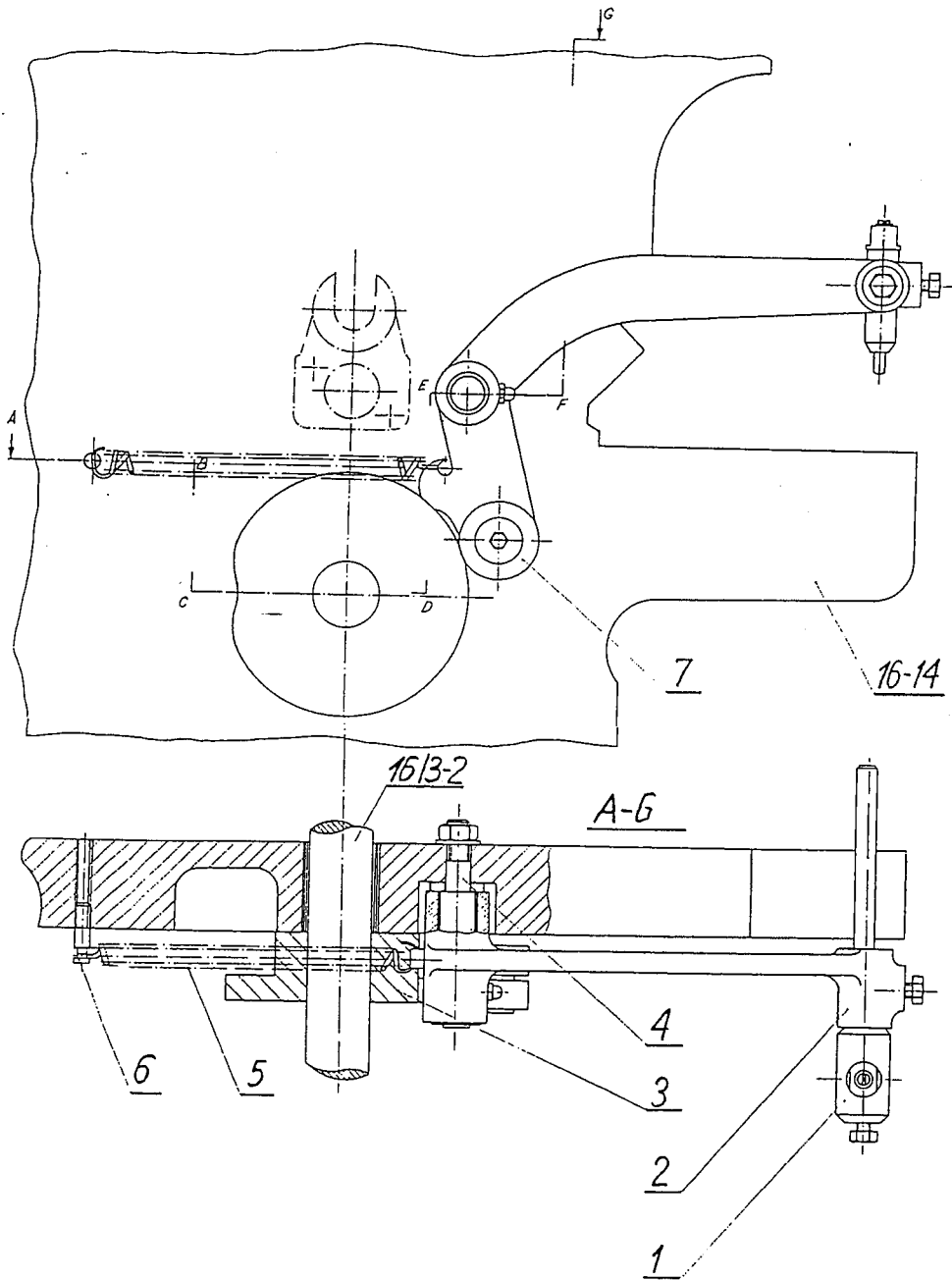

Fig. 16/10



Packing Machine XPG40
Spare parts catalogue

Operating and
Maintenance Instr.

page 71 90. pages

Fig.16/10 Paper feeding sensor XPG 40-16-24-00

Part No	Group	Drawing No	Part name	Qty	Notes
16/10-1		XPG 40-16-24-01	Sensor complete	1	
16/10-2		XPG 40-16-24-02	Lever	1	
16/10-2/1	B	EHN 5640-131-620B	Sleeve	2	
16/10-3	E	XPG 40-16-24-03	Cam	1	
16/10-4	B	XPG 40-16-24-04	Pin	1	
16/10-5	A	EHN 420	Spring 10x1x115	1	
16/10-6		EHN 6212	Spring catch 6212- -061-001	1	
16/10-7	A	BHN 405U	Roll complete 30/10 x31A	1	

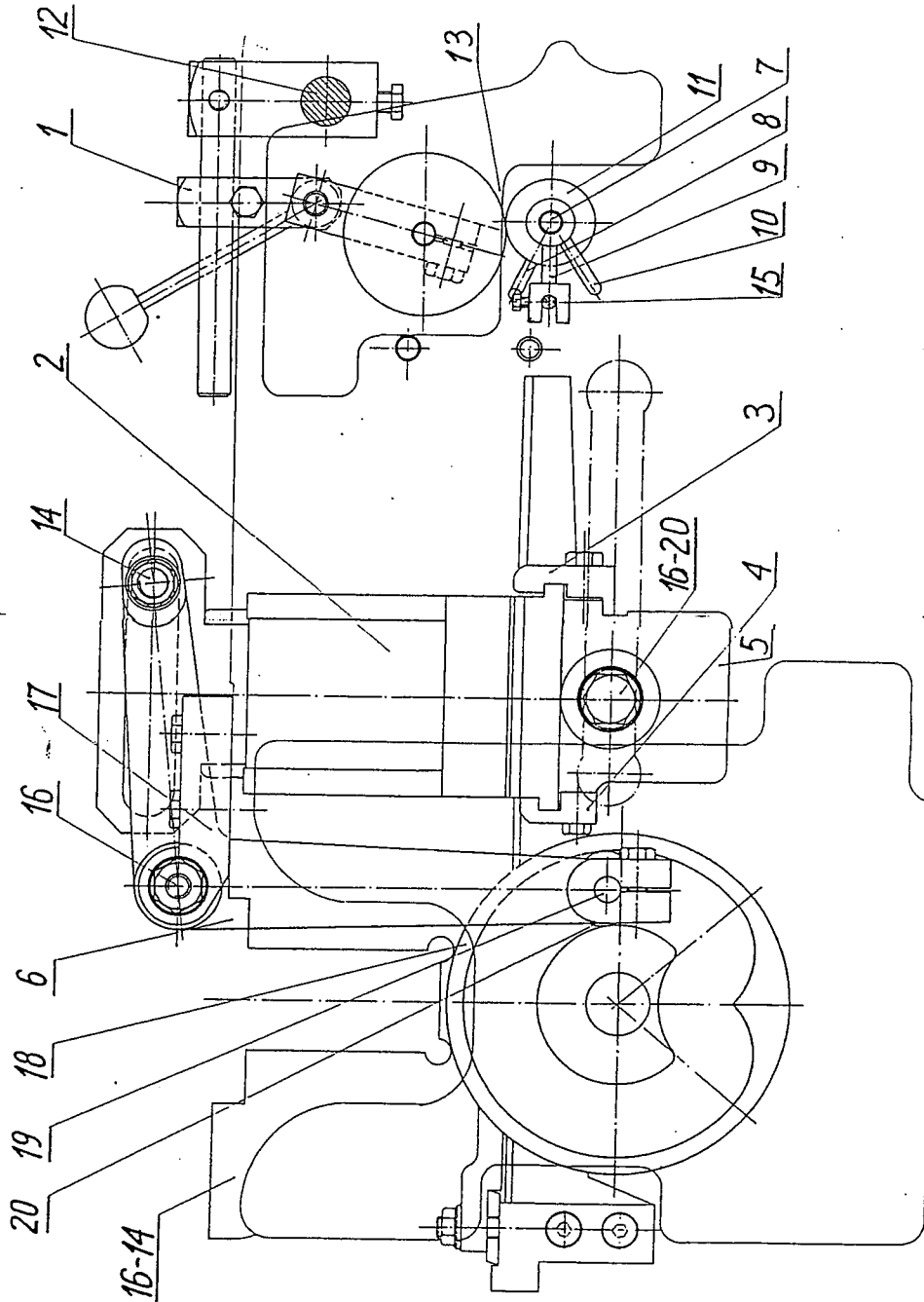

Fig. 16/11



Packing Machine XPG40
Spare parts catalogue

Operating and
Maintenance Instr.

page 73 90 pages

Fig.16/11 - Brake and date stamp XPG 40-16-26-00

Part No	Group	Drawing No	Part name	Qty	Notes
16/11-1		XPG 40-16-26-01	Brake complete	1	Sub-ass. Drwg.16/12
16/11-2		XPG 40-16-26-02	Date stamp	1	Import
16/11-3		XPG 40-16-26-03	Pressure	1	
16/11-4		XPG 40-16-26-04	Pressure	1	
16/11-5		XPG 40-16-26-05	Base	1	
16/11-6		XPG 40-16-26-06	Lever	1	
16/11-6A		EHN 5640-168-020B	Sleeve	2	
16/11-7		XPG 40-16-26-07	Fin	2	
16/11-8		XPG 40-16-26-08	Stop complete	1	
16/11-9		XPG 40-16-26-09	Row complete	1	
16/11-10		XPG 40-16-26-15	Stop complete	1	
16/11-11		XPG 40-16-26-10	Axle	1	
16/11-12		XPG 40-16-26-11	Cross beam	1	
16/11-13		XPG 40-16-26-12	Guide	1	
16/11-14	E	XPG 40-16-26-13	Pin	1	
16/11-15		XPG 40-16-26-14	Weight	2	
16/11-16	E	XPG 40-16-26-16	Pin	1	
16/11-17		XPG 40-16-26-17	Bracket	1	
16/11-18	E	XPG 40-16-21-03	Cam	1	
16/11-19	A	EHN 405.2	Pin 10x31	1	
16/11-20	A	EHN 405.1	Roll 30	1	

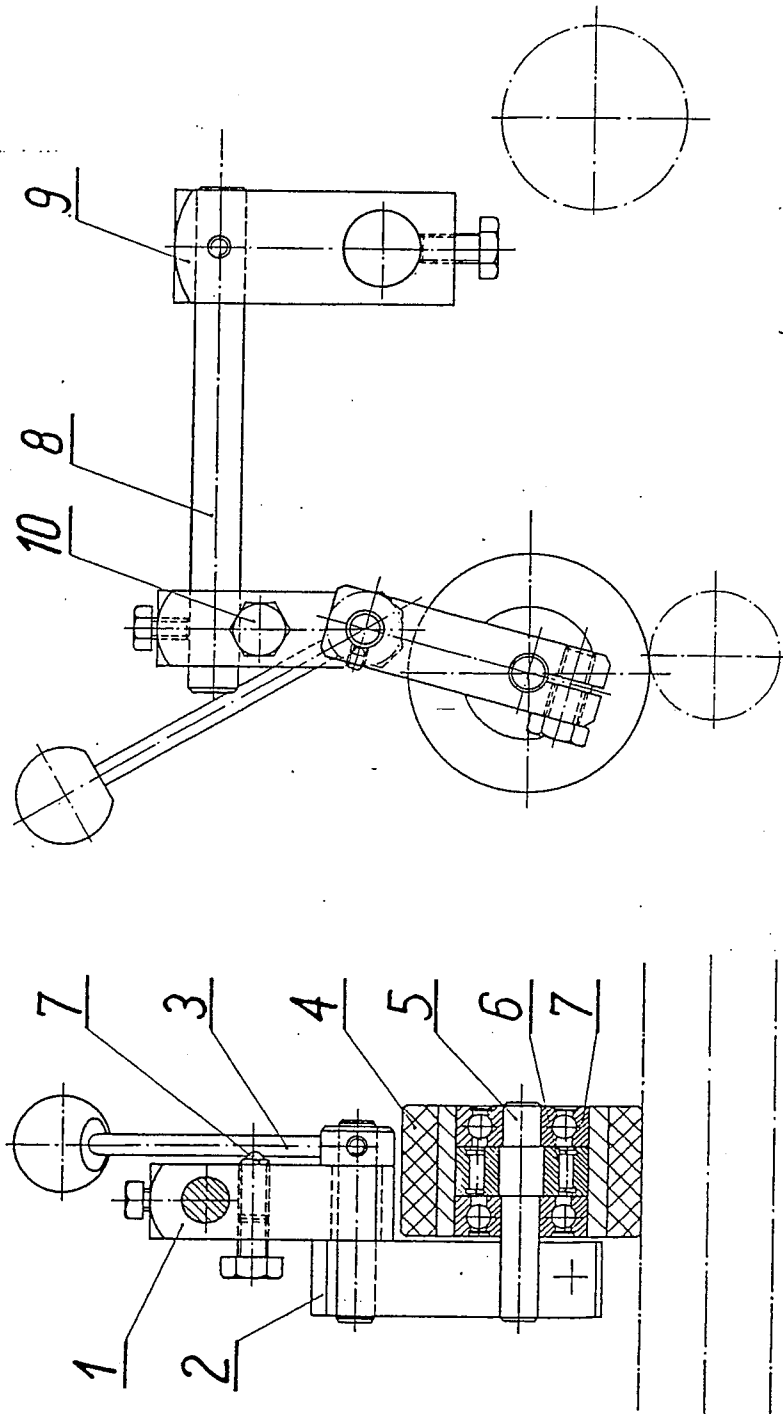

Fig. 16/12



Packing Machine XFG40
Spare parts catalogue

Operating and
Maintenance Instr.

page 75 90 pages

Fig.16/12 - Brake complete XFG 40-16-26-01

Part No	Group	Drawing No	Part name	Qty	Notes
16/12-1		XFG 40-16-26-01A/1	Holder	1	
16/12-2		XFG 40-16-26-01/2	Bracket	1	
16/12-3		XFG 40-16-26-01/3	Lever	1	
16/12-4	E	XFG 40-16-26-01/4/1	Roller	1	
16/12-5		XFG 40-16-26-01/4/2	Axle	1	
16/12-6			Coupling NFS12	1	
16/12-7		PN-69/M-86100	Bearing 6304RS	2	
16/12-8		XFG 40-16-26-01/5	Rod	1	
16/12-9		XFG 40-16-26-01/6	Holder	1	
16/12-10		BHN 5084	Latch KMB	1	

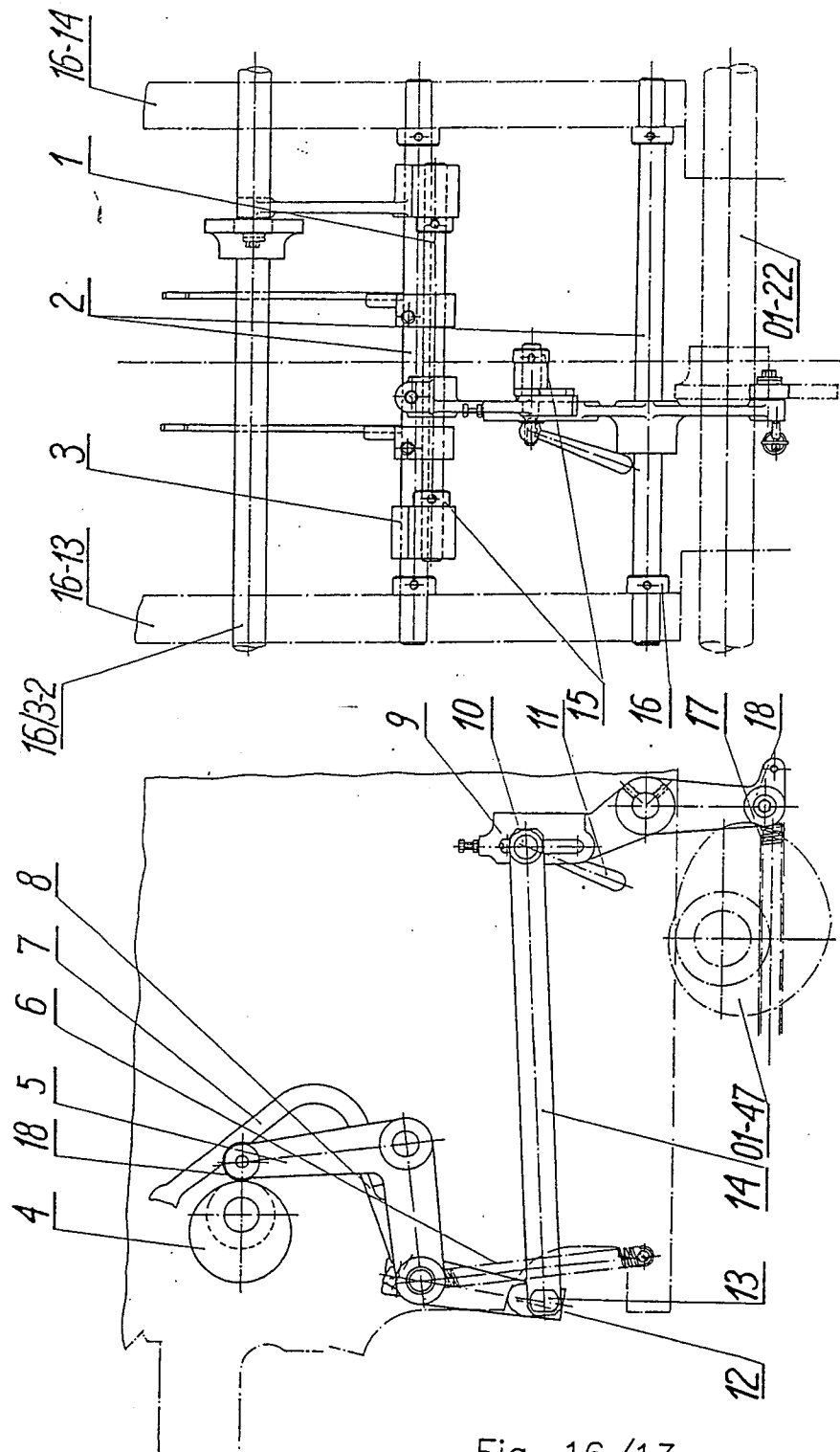

Fig. 16/13



Packing Machine XPG40
Spare parts catalogue

Operating and
Maintenance Instr.

page **77** **90** pages

Fig.16/13 Paper pusher XPG 40-16-27-00

Part No	Group	Drawing No	Part name	Qty	Notes
16/13-1		XPG 40-16-27-01	Shaft	1	
16/13-2	B	XPG 40-16-27-02	Shaft	2	
16/13-3		XPG 40-16-27-03	Lever	1	
16/13-3/1	B	EHN 5640-168-040A	Sleeve	1	
16/13-4	B	XPG 40-16-27-04	Cam	1	
16/13-5		XPG 40-16-27-05	Lever	1	
16/13-5/1	E	BHN 5640-162-040A	Sleeve	1	
16/13-6		BHN 420	Spring 15x1,5x115	1	
16/13-7	E	XPG 40-16-27-07	Ejector	2	
16/13-8		XPG 40-16-27-08	Lever	2	
16/13-9		XPG 40-16-27-09/1	Lever	1	
16/13-10	B	XPG 40-16-27-09/2	Pin	1	
16/13-11		XPG 40-16-27-09/6	Grip	1	
16/13-12		XPG 40-16-27-10	Lever	1	
16/13-13	E	XPG 40-16-27-11	Pin	1	
16/13-14		XPG 40-16-27-12	Connector complete	1	
16/13-14/1	B	XPG 40-16-27-12/3	Sleeve	1	
16/13-15	E	EHN 5231	Retaining ring A16	3	
16/13-16	E	EHN 5231	Retaining ring A20	4	
16/13-17	A	EHN 420	Spring 18x2x220	1	
16/13-18	A	EHN 405.U	Roll complete 30/10x31A	2	

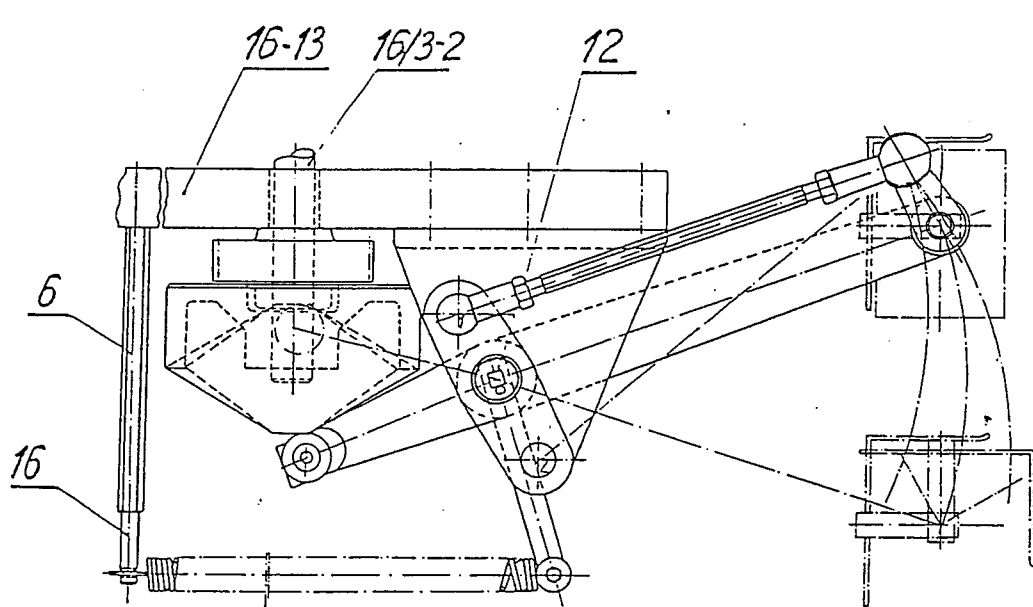
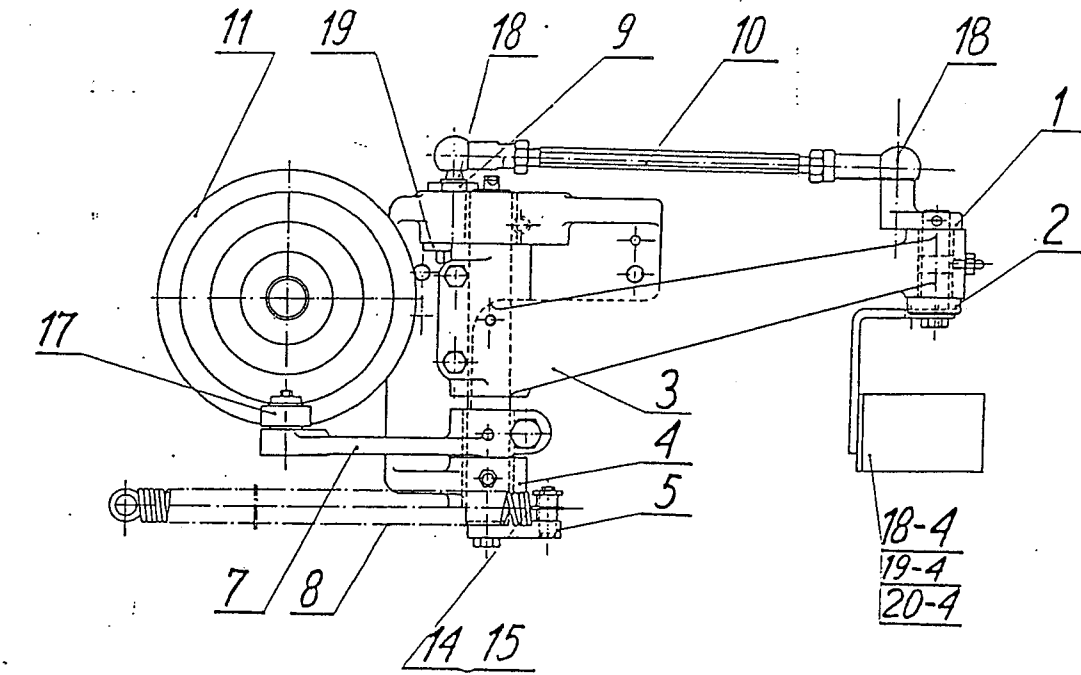

Fig. 17



Packing Machine XPG40
Spare parts catalogue

Operating and
Maintenance Instr.

page 79 90 pages

Fig.17 - Cake pusher XPG 40-17-00-00

Part No	Group	Drawing No	Part name	Qty	Notes
17-1		XPG 40-17-00-01	Lever	1	
17-2	B	XPG 40-17-00-02	Pin	1	
17-3		XPG 40-17-03-00	Lever with roll	1	
17-3/1	B	XPG 40-17-03-02	Shaft	1	
17-3/2	B	EHN 5640-162-015E	Sleeve	2	
17-4		XPG 40-17-04-00	Bracket	1	
17-4/1	B	BHN 5640-253-030A	Sleeve	2	
17-5		XPG 40-17-00-05	Connector	1	
17-6		XPG 40-17-00-06	Pin	1	
17-7		XPG 40-17-00-07	Lever	1	
17-8	A	XPG 40-17-08-00	Spring complete	1	
17-9		XPG 40-17-00-09	Pin	1	
17-10		XPG 40-17-10-00	Connector complete	1	
17-10/1	B	1999-260-130	Joint SF10	1	
17-11		XPG 40-17-00-11	Cam	1	
17-12	B	XPG 40-17-03-02	Shaft	1	
17-13		EHN 5441	Pin 5441-010-032	1	
17-14		EHN 405.2	Pin 10x26	1	
17-15		EHN 405.3	Washer 18A	1	
17-16		EHN 6212	Spring catch 6212- -103-501	1	
17-17	A	EHN 405.U	Roller complete 30/10x31A	1	
17-18	B	EHN 5406	Ball-and-socket joint A16	1	
17-19		EHN 5232	Washer 5232-010- -005	1	



PACKING MACHINE –type XPG40
SPARE PARTS CATALOGUE

Page 80

Pages 90

EQUIPMENT FOR FORMAT 110x62.6x45

Picture No : XPG40-74-00-00

Position	Part No	Picture or standard No	No of parts	Remarks
19-1	Forming head	XPG40-74-01-00	1	Pict.19/1
19-2	Pressure pad compl.	XPG40-74-02-00	1	Pict.01
19-3	Plunger compl.	XPG40-74-03-00	1	Pict.16
19-4	Ejector compl.	XPG40-74-04-00	1	Pict.17
19-5	Cut off lever compl.	XPG40-74-05-00	1	Pict.19/2
19-6	Mouthpiece compl.	XPG40-74-06-00	1	Pict.04
19-7	Bottom	XPG40-74-00-07	8	Pict.10
19-9	Overturn piece	XPG40-74-09-00	1	Pict.03
19-10	Bender	XPG40-74-00-10	1	Pict.02
19-11	Wrapper compl.	XPG40-74-11-00	1	Pict.02
19-12	Wrapper compl.	XPG40-74-12-00	1	Pict.02
19-13	Bending strip	XPG40-74-13-00	1	Pict.01
19-14	Initial bender	XPG40-74-14-00	1	Pict.16/2

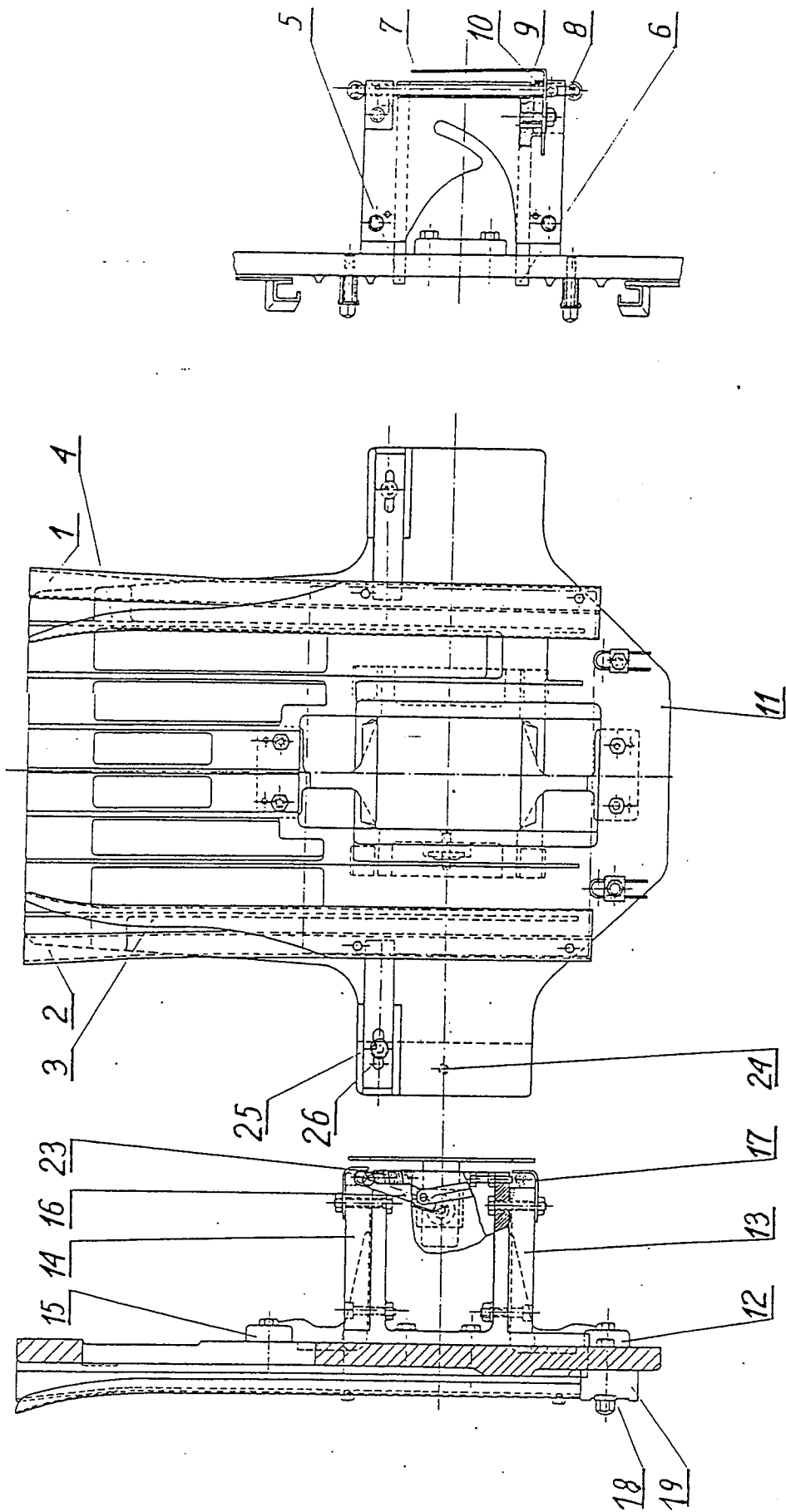

Pict. 19/1



PACKING MACHINE –type XPG40
SPARE PARTS CATALOGUE

Page 82
Pages 90

Pict. 19/1

FORMING HEAD

Picture No : XPG40-74-01-00

Position	Part No	Picture or standard No	No of parts	Remarks
1	Right guide	XPG40-74-01-01	1	
2	Left guide	XPG40-74-01-02	1	
3	Right guide	XPG40-74-01-03	1	
4	Left guide	XPG40-74-01-04	1	
5	Right yoke	XPG40-74-01-05	1	
6	Left yoke	XPG40-74-01-06	1	
7	Roll	XPG40-74-01-07	2	
8	Axle	XPG40-74-01-08	2	
9	Coat scraper	XPG40-74-01-09	1	
10	Sleeve	XPE50-03-18	4	
11	Plate	XPG40-74-01-11	1	
12	Heart-shaped bender I	XPG40-74-01-12	1	
13	Head wall I	XPG40-74-01-13	1	
14	Head wall II	XPG40-74-01-14	1	
15	Heart-shaped bender II	XPG40-74-01-15	1	
16	Lever	XPG40-74-01-16	2	
17	Roller pressing angle bar	XPE50-03-12	4	
18	Bumper	XPG40-18-01-14	2	
19	Washer	XPG40-18-01-15	2	
20	Spring 10x1x100	BHN 420	2	

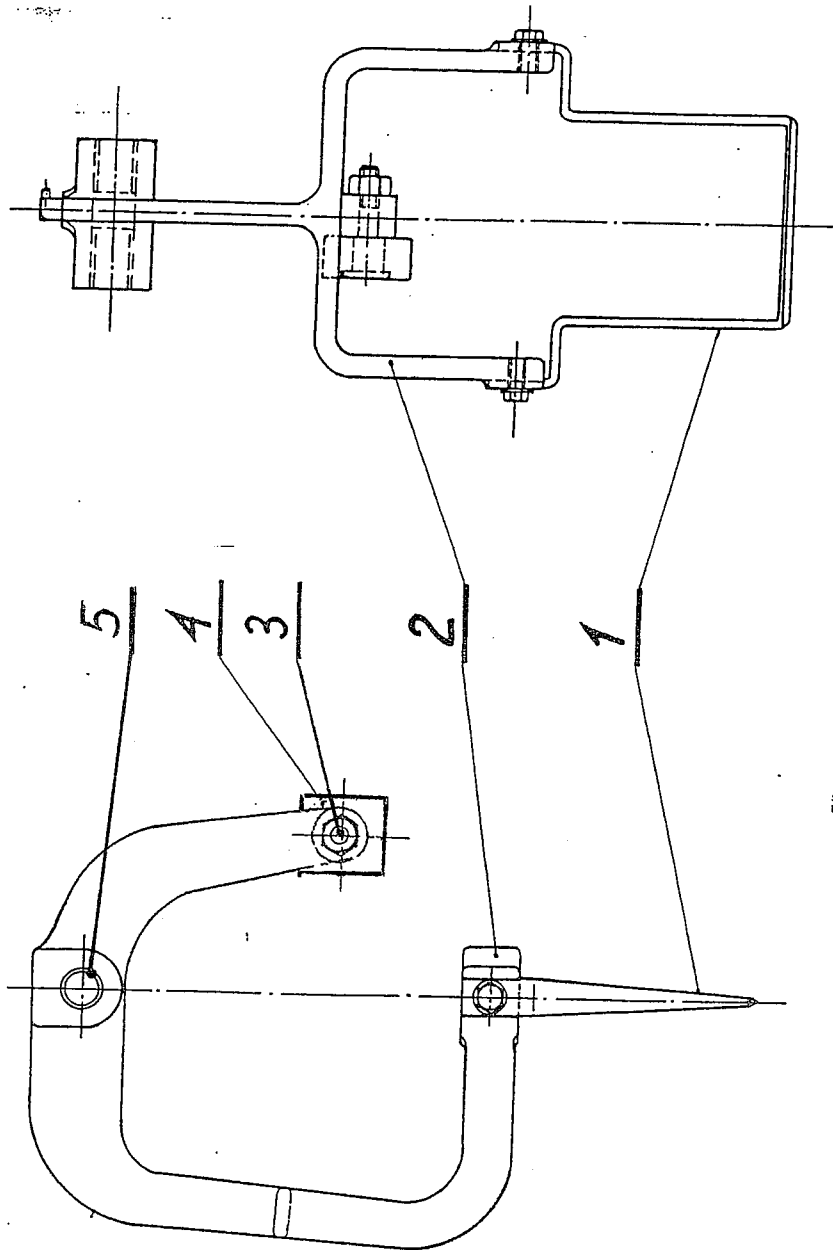

Pict. 74/2



PACKING MACHINE –type XPG40
SPARE PARTS CATALOGUE

Page 84

Pages 90

Pict. 74/2

CUT OFF LEVER COMPL.

Picture No : XPG40-74-05-00

Position	Part No	Picture or standard No	No of parts	Remarks
1	Cutter	XPG40-74-05-01	1	
2	Lever	XPG40-18-05-02	1	
3	Eccentric pin	XPG40-18-05-03-1	1	
4	Slider	XPG40-18-05-04	1	
5	Sleeve	BHN5640-162-025B	2	

- 85/1 -

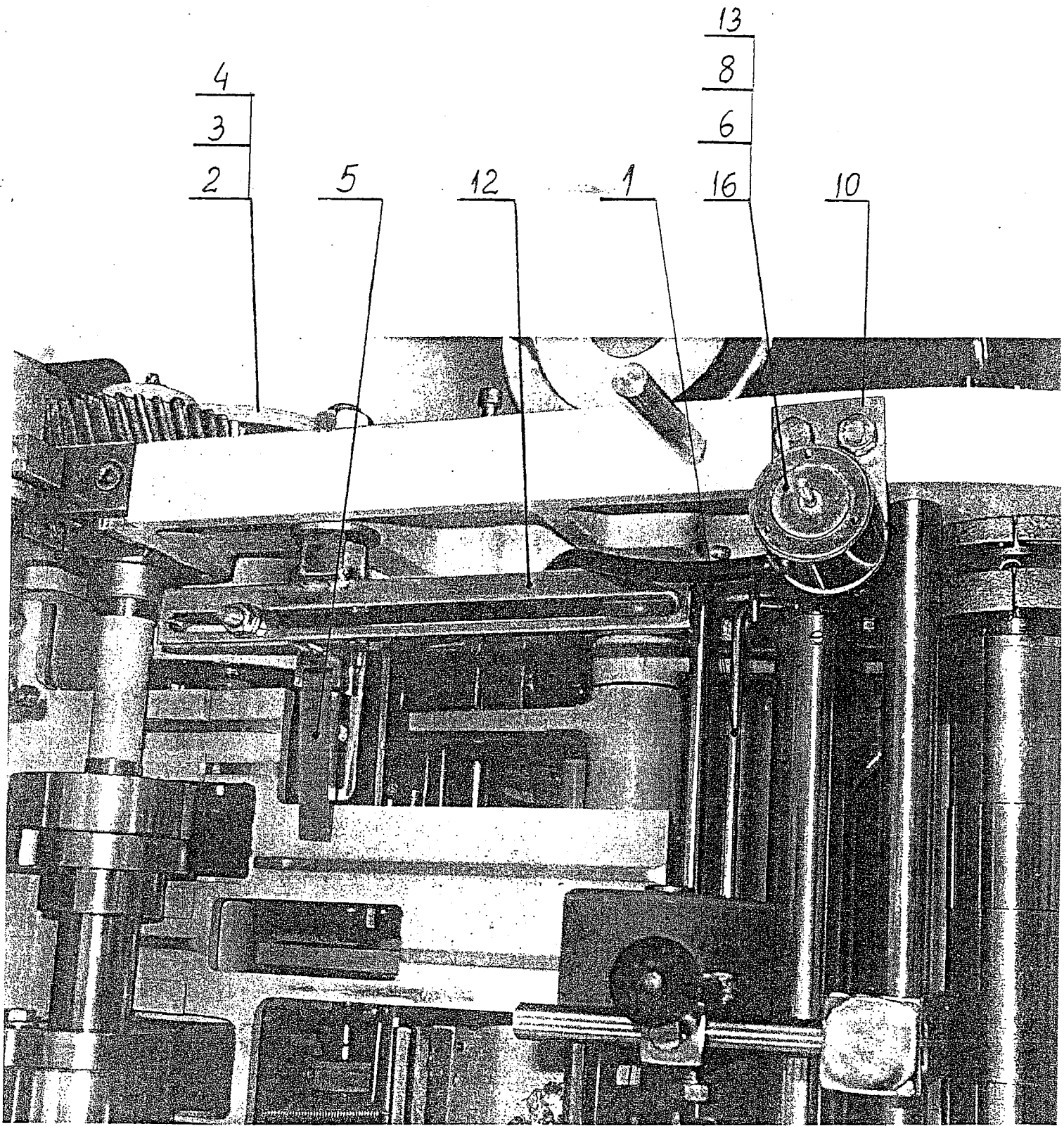

Pict. 16/51-1

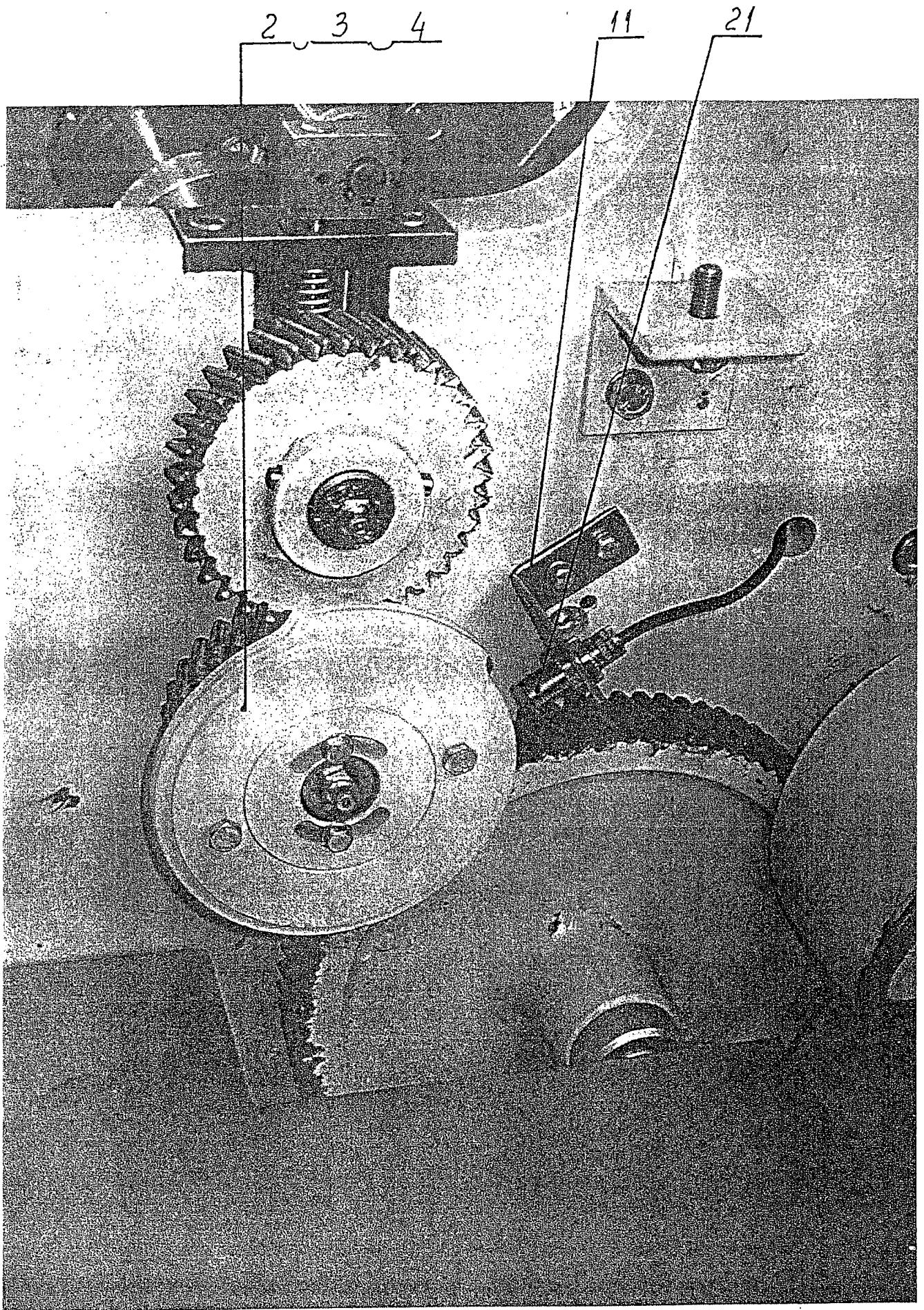

Pict. 16151-2

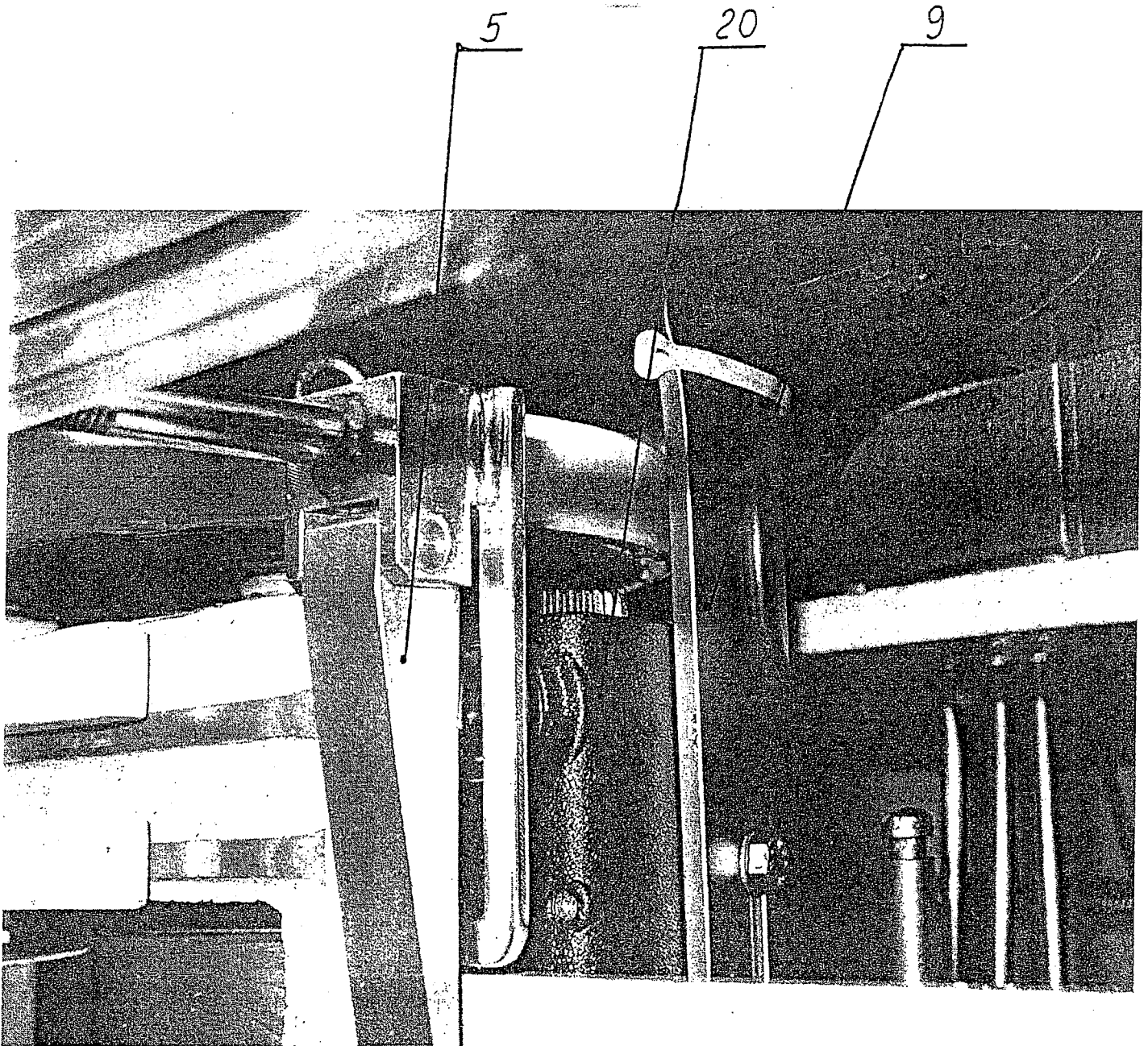

Pict. 16/51-3



PACKING MACHINE -type XPG40
SPARE PARTS CATALOGUE

Page 86

Pages 90

Pict. 16/51

Instalation of photocell

Picture No : XPG40-16-51-00

Position	Picture or standard No	Part No	No of parts	Remarks
1	121-16-50-02	Bow	1	
2	121-16-50-03/1-2	Cam	1	
3	121-16-50-03/2-1	Cam	1	
4	121-16-50-03/3	Washer	1	
5	121-16-51-06	Foil guid	1	
6	121-16-50-07-1	Screw	1	
7	121-16-50-08-1	Console	1	
8	121-16-50-09-1	Screw	2	
9	121-16-50-26-6	Bracket of potocell	1	
10	121-16-50-28-3	Bracket	1	
11	121-16-50-44	Bracket of sensor	1	
12	121-16-18-03-1	Guid	1	
13	M0789-202-100-32	Head SGS-M4	2	
14	M0918-417-000-20	Amplifier FOTO WFS1 AGMA	1	Elec. cabinet
15	M1115-297-503-11	Push-button NEF 30-PsXY	1	Console
16	M0789-200-120-23	Elektromagnet	1	Elec. cabinet
17	M0918-417-000-14	Socket G-11B RTs-416	1	Elec. cabinet
18	M1156-112-001-01	Bridge-rectifier 10A BR102	1	Elec. cabinet
19	M1115-232-311-09	Tripper 1P S191 B6A	1	
20	M0918-990-100-11	Photocell XUR-K0955D	1	
21	M0943-139-001-13	Sensor XS1-N12NA349	1	
22	M1131-159-211-20	Connector SAK4/35 nr044366	10	Elec. cabinet
23	M1131-159-200-10	Holder EW35 nr038356	1	Elec. cabinet



Packing Machine XPG40
Spare parts catalogue

Operating and
Maintenance Instr.

page 87 90 pages

Shields XPG 40-21-00-00

Part No	Group	Drawing No	Part name	Qty	Notes
21-1		XPG 40-21-00-01	Cover	1	See: Fig.01/8
21-2		XPG 40-21-02-00	Front lower shield complete	1	Fig.07
21-3		XPG 40-21-00-03	Pulley cover	1	Fig.01/4
21-4		XPG 40-21-04-00	Hinged front shield	1	Fig.16
21-4/1	B	XPG 40-21-04-01	Shield	1	
21-5		XPG 40-21-00-05	Barrier	1	Fig.04
21-6		XPG 40-21-00-06	Connector	2	Fig.16/5
21-7		XPG 40-21-00-07	Top shield	1	Fig.01/1
21-8		XPG 40-21-08-00	Top shield	1	Fig.01/1
21-9		XPG 40-21-00-09	Back shield	1	Fig.07
21-10		XPG 40-21-10-00	Main shield	1	Fig.01
21-11		XPG 40-21-00-11	Side shield	1	Fig.16
21-13		XPG 40-21-13-00	Switch off device	1	Fig.16
21-14		XPG 40-21-14-00	Top front shield	1	Fig.16
21-15		XPG 40-21-15-00	Chain guard compl.	1	Fig.16/5



Packaing machine XPG-40
Spare parts catalogue

Operating and
Maintenance Instr.

page **89** **90** pages

Electrical unit XPG-40-24-00-00

Part No	Group	Drawing No or norm	Part name	Qty	Notes
1		XPG-40-24-01-00	Control desk	1	see pic.16
2		XPG-40-24-00-03	Pocket	1	see pic.07
3		XPG-40-24-02-10	Sleeve	4	see pic.01/1
4		XPG-40-24-02-00	Electrical cabinet	1	see pic.01/1



Packaing machine XPG-40
Spare parts catalogue

Operating and
Maintenance Instr.

page 88 90 pages

Electrical unit XPG-40-24-00-00

Part No	Group	Drawing No or norm	Part name	Qty	Notes
Q1		M1115-300-000-59	Main switch P1-25/EA/SVB	1	
F1		M1115-233-310-20	Fuse3P C60N C20A	1	
F3		M1115-233-103-20	Fuse1P C60N C2A	1	
F4		M1115-233-106-10	Fuse 1P C60N B6A	1	
T1		M1115-730-020-21	Transformer TMa-100T 100VA 220/24V-28V 50Hz	1	
M1		M1111-331-116-06	Motor with brake Sg112 M6HL 2,2kW 950rpm	1	
F2		M1115-300-000-32	Thermal overload relays LR2-K0314	1	
K1,K3,K4		M1115-300-000-31	Contactors 24V/50Hz LP1-K0910B7	3	
K2, K5		M0918-411-216-10	Contactors 24V/50Hz R15-1012-23-3024	2	
S1		M1115-297-503-12	Pushbuttons NEF-d-c-11	1	
S3,S4,S6		M1115-297-514-10	Pushbuttons NEF-K-z-11	3	
S2+H2		M1115-297-554-11	Pushbuttons NEF-W-z-11-1	1	
H1		M0917-421-511-01	Pilot lights NEF-s-b-1	1	
S7		M1115-293-020-70	Limit switch 83133 54A R=35,75mm	1	
S8		M1115-293-003-32	Limit switch MPO-4	1	
S9		M1115-293-011-12	Limit switch 83759-1 -head 81050-1	1	
S5		M1115-293-010-02	-body 83758-0		
S10		M1115-293-030-10	Limit switch 83544-03 Paper detector	1	



Packaing machine XPG-40
Spare parts catalogue

Operating and
Maintenance Instr.

page 90 90 pages

Photomark detector unit XPG-40-16-50-00

Part No	Group	Drawing No or norm	Part name	Qty	Notes
Y1		M0789-200-120-23	Solenoid actuator. typ 2503 24v/50Hz	1	
B101		M0918-990-100-11	Photoelectric detektor XUR-K09550	1	
V1		M1115-233-106-10	Bridge-rectifier BP1004	1	
S21		M1115-297-503-11	Twisted button	1	
B102		M0943-139-001-13	Inductive sensor	1	
A1		M0918-417-00-20	Photomark amplifier WF-S1	1	