

Homogenizer HL8

- Max. 60.000 l/h
- Homogenizing pressure up to 400 bar
- Motor power: max. 355 kW
- Optional in aseptic execution
- Pump valve selection suitable for the product
- Machine cabinet for sound reduction up to 6 dB(A)

*Weight with motor: max. 10.700 kg
Technical changes reserved!*

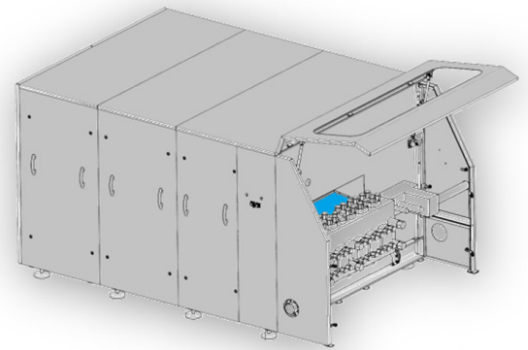

Poppet valve

For low viscose and slight abrasive products

Model	Max. Pressure	Max. Capacity
HL8	(bar)	(l/h)
-150T	150	60.000
-200T	200	55.000
-210T	210	50.000
-250T	250	42.000
-300T	300	35.000
-350T	350	30.000
-400T	400	24.000

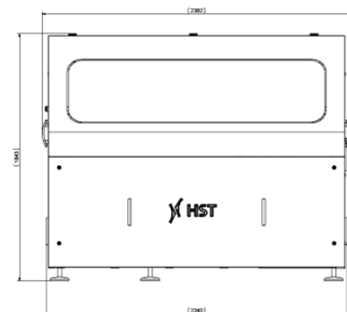

Ball valve

For high viscose and strong abrasive products

Model	Max. Pressure	Max. Capacity
HL8	(bar)	(l/h)
-150K	150	55.000
-200K	200	50.000
-210K	210	45.000
-250K	250	40.000
-300K	300	32.000
-350K	350	28.000
-400K	400	21.500

