

 **Primodan** - When flexibility is your priority

# RT-LINE

TECHNICAL  
SPECIFICATION



Bucket filling and closing machine

# RT-LINE

BUCKET FILLING AND CLOSING MACHINE

## TECHNICAL DRAWING

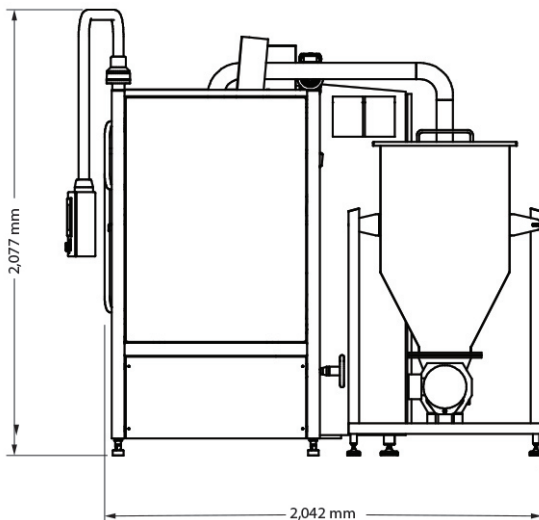
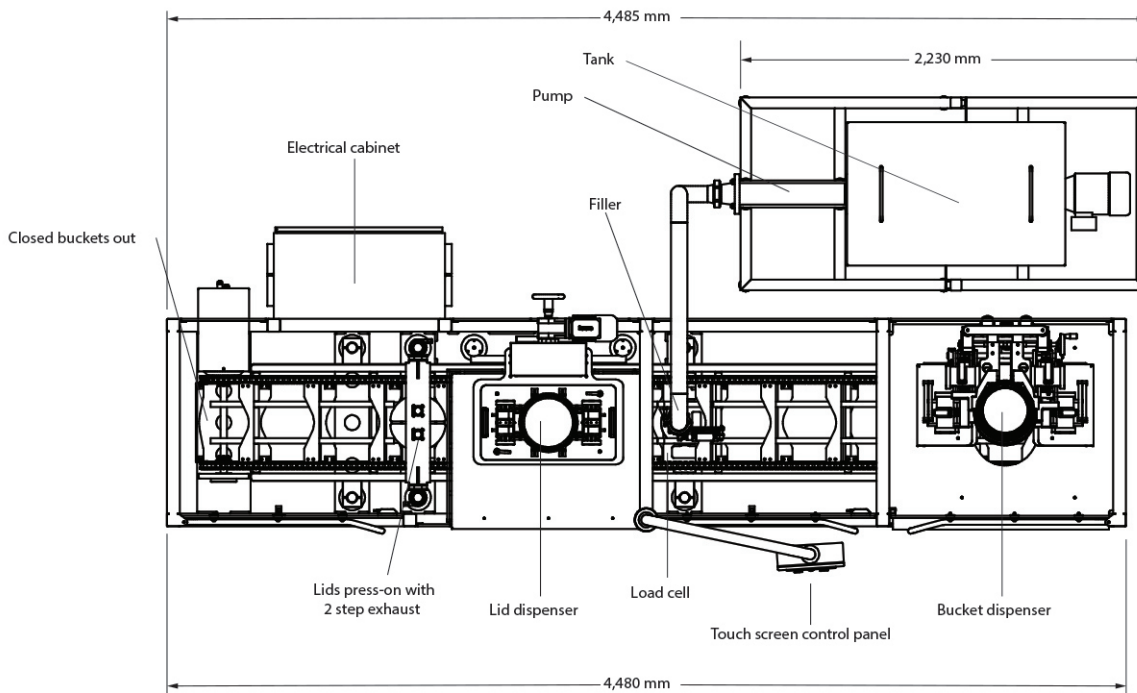

## TECHNICAL SPECIFICATION

Capacity:.....Up to 3,600 units/hour  
 Maximum bucket diameter:.....300 mm  
 Pneumatic requirement:.....Minimum 6 bar  
 Electrical consumption:.....2 kW  
 Materials:.....Stainless steel  
 CE certificate / EU norm

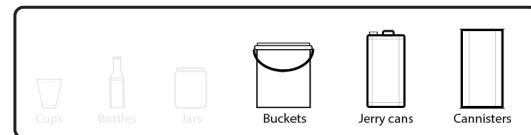

## MACHINE SPECIFICATION

Bucket dispenser  
 Filling and load cell  
 Lid dispenser  
 Lid press-on with 2 step ventilation

## OPTIONS

Bucket buffer  
 Filling system – piston, flow filling or dosing pump  
 Foil from roll stock  
 UV-C treatment of roll stock foil  
 Lid buffer

UV-C treatment of buckets  
 Pulsed Light treatment of buckets or/and lids  
 Central lubrication system  
 Ultra clean execution