

HST Homogenizers

HST Maschinenbau GmbH

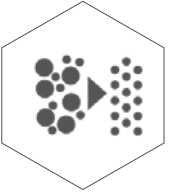

HST banks on tradition and know-how

As a manufacturer of homogenizers and piston pumps, HST Maschinenbau GmbH enhances Krones process equipment with its additional key technology. HST process equipment stands out through its combination of proven experience and the most up-to-date technology: inexpensive and energy saving, fast, with assured quality and high versatility.

At a glance

- Decades of experience in the production of high-pressure homogenizers and piston pumps
- Inexpensive complete solutions: Fast with assured quality and high versatility
- Homogenizers process 10 up to 60,000 litres per hour at a pressure of 100 to 1,500 bar (depending on configuration)



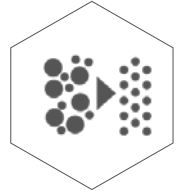

Range of services at a glance

Our technology

- Production of high-pressure homogenizers and piston pumps
- Spare and wear parts
- Maintenance and repairs
- Trade in rental and used machines
- Consulting with regard to applications
- Commissioning

Our strong points

- Decades of experience
- 24/7 service
- Quality assurance
- Speed
- Low-cost solutions
- Flexibility

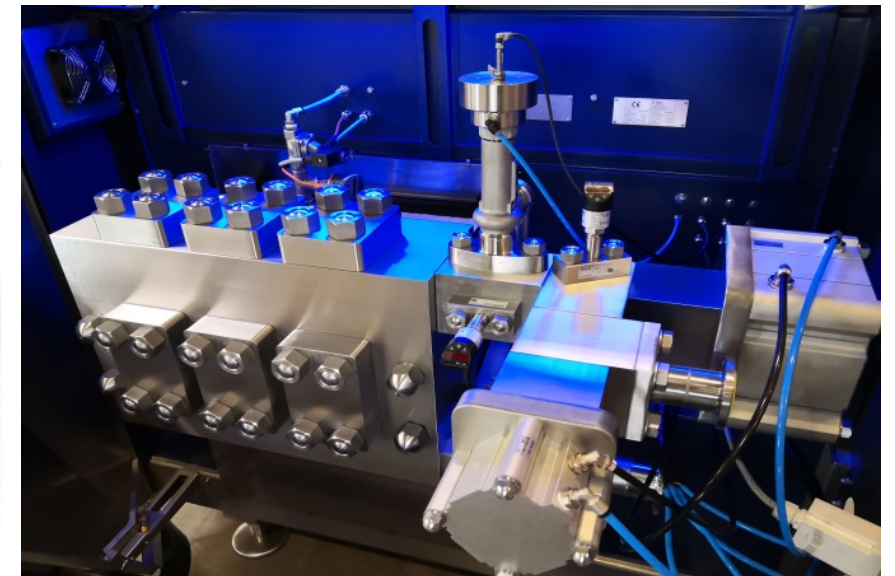
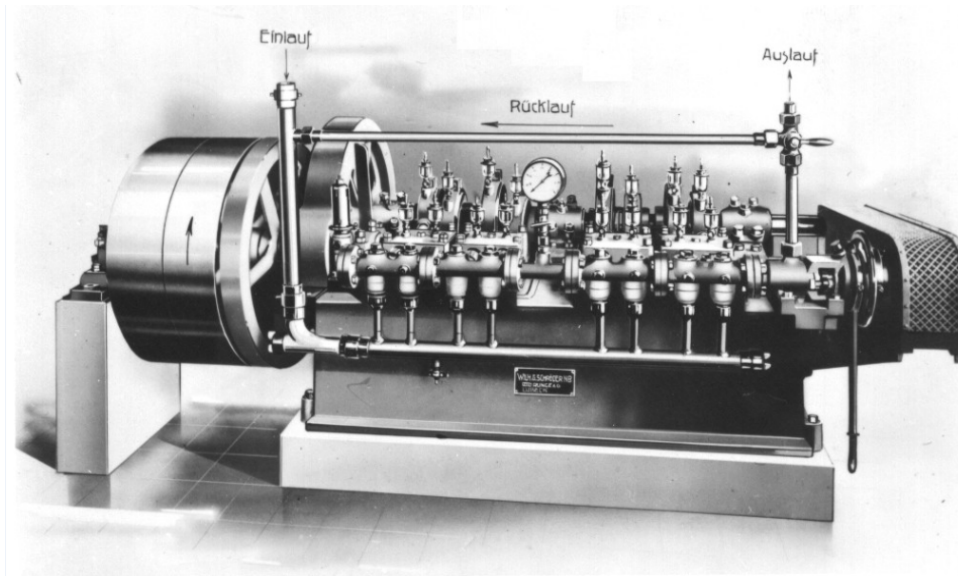

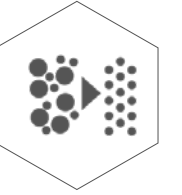

HST Maschinenbau GmbH

- Founded in 2000
- Production site in Dassow
- Operating in the Krones Group since 2014

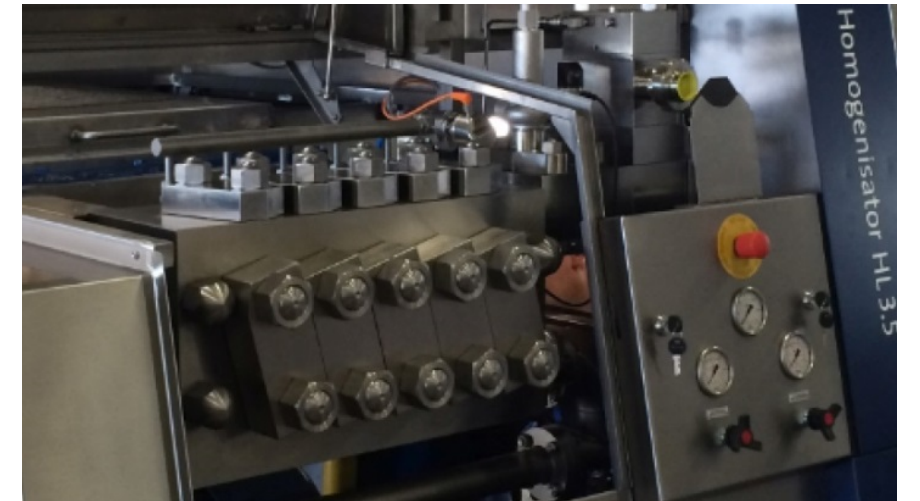

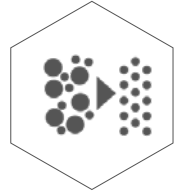

Application areas

Food industry

- Fresh milk
- Cream
- Vegetable juices
- UHT milk
- Yoghurt
- Baby and infant food
- Condensed milk
- Ketchup
- Sauces and dressings
- Mixed ice cream
- Fruit juices
- Egg products
- Special drinks



Pharmaceutical and cosmetics industry

- Intravenous emulsions
- Liposomes
- Ingredients
- Textures
- Beauty creams
- Dyes
- Ointments
- Cell disruption
- Pigment dispersions



Chemicals industry

- Lubricants
- Fuels/water emulsions
- Wax emulsions
- Insecticides/herbicides
- Resin dispersions
- Nanosomes
- Colours
- Latex



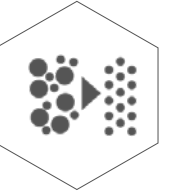

High-pressure pumps for the HL series

- Throughput range between 10 and 60,000 l/h
- Operating pressure up to 700 bar (10,000 psi)
- Models: HLL0, HL1 – HL8
- Design details:

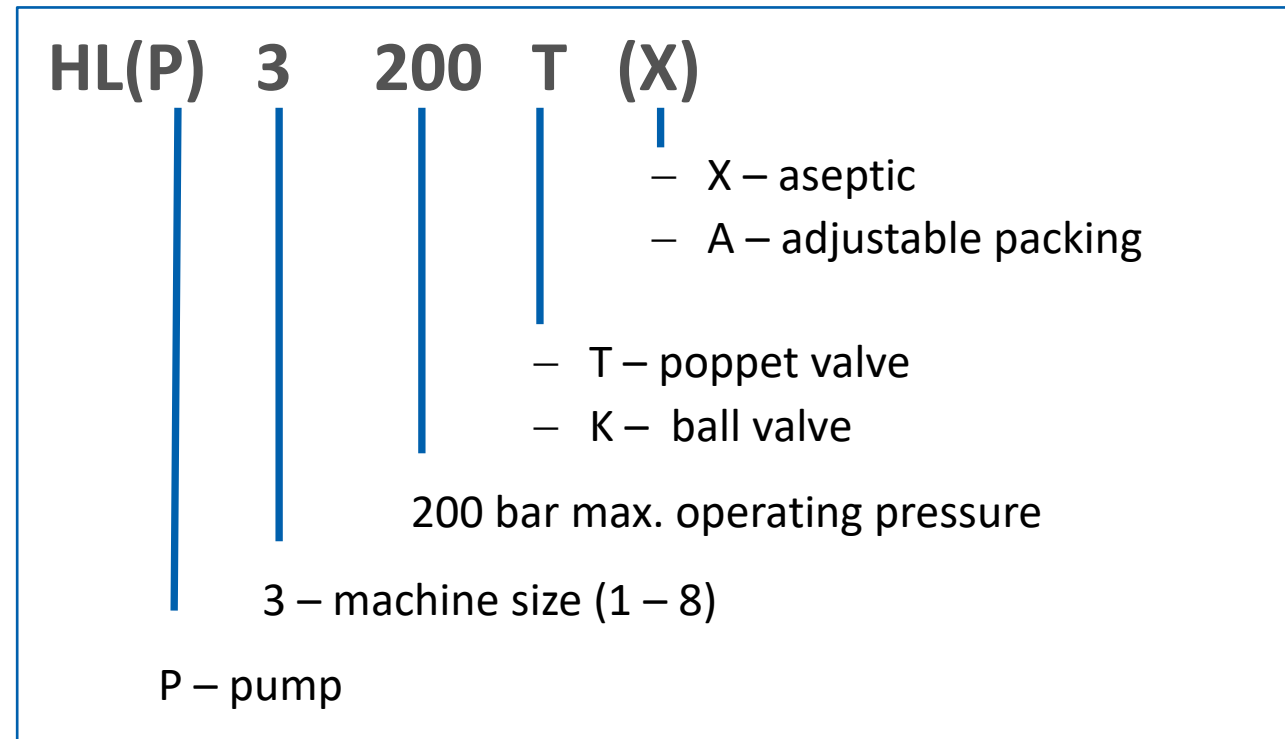



Performance overview – HST homogenizers

Version	Max. throughput (l/h)									Power (kW)	
	150 bar	200 bar	250 bar	300 bar	350 bar	550 bar	700 bar	800 bar	1500 bar		
HLL0										10	1.1
HL1	285	285	230	175	175	70	60				3
HL2.5	2,800	2,100	1,700	1,250	1,200	750	360	360			15
HL2	5,800	4,600	3,500	2,500	2,100	1,500	550	500			30
HL3	11,500	10,000	7,500	6,000	5,500	3,000	1,400				68
HLI55	10,000	7,600	6,000	5,000	4,300	2,700	2,100				55
HLI75	14,000	10,500	8,500	7,000	6,000	3,800	2,900				75
HLI90	17,500	13,000	9,600	8,000	6,600	4,200	2,900				90
HL4	24,000	18,000	15,000	12,000	10,500	6,600	4,000				110
HL5	34,000	28,000	21,000	18,000	15,000	9,500	7,500				160
HL6	45,000	35,000	30,500	22,500	19,500	13,500	9,500				220
HL8	60,000	55,000	45,000	35,000	30,000						355

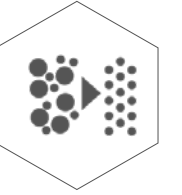

Homogenizers – pump valve design

Poppet valves

- High volumetric efficiency with a low product viscosity
- Permit high speeds $> 160 \text{ min}^{-1}$
- Suitable for smooth and only slightly abrasive products
- Max. product viscosity up to 500 mPas

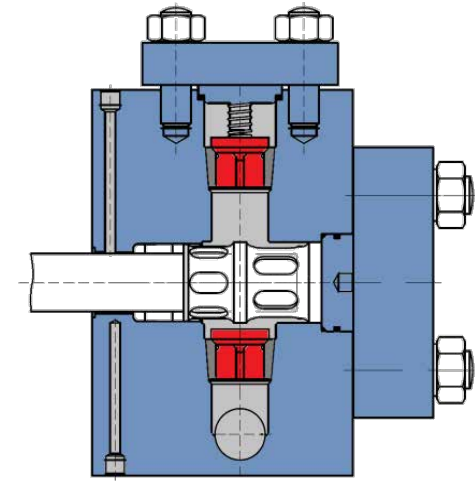

Ball valves

- Higher particle tolerance
- Product viscosity up to approx. 1,000,000 mPas
- Limited speed up to approx. 160 min^{-1}

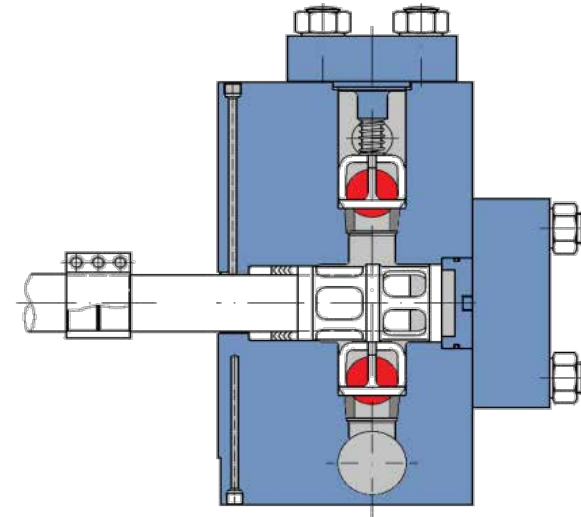

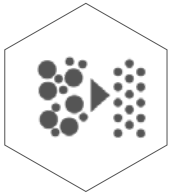

The working principle of high-pressure homogenization

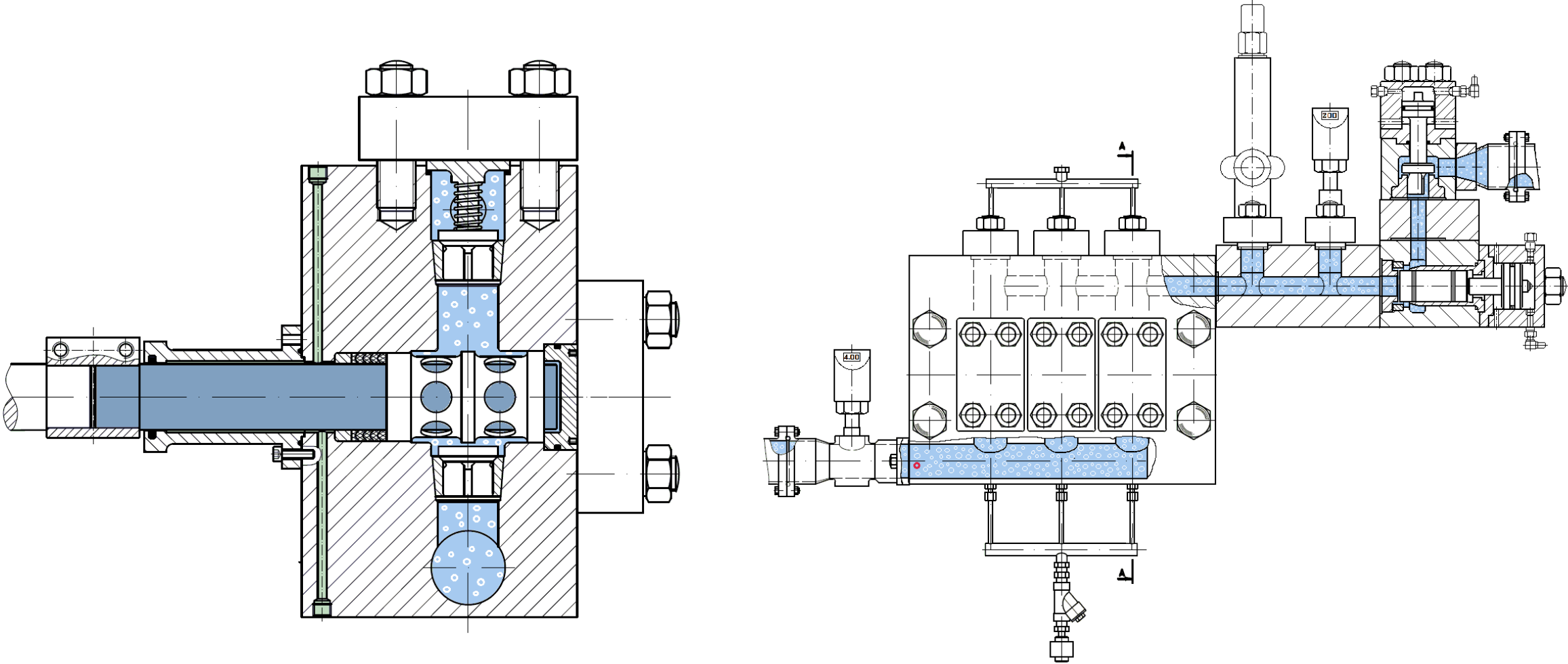

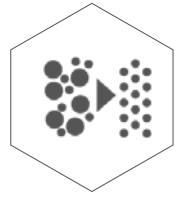

The working principle of high-pressure homogenization

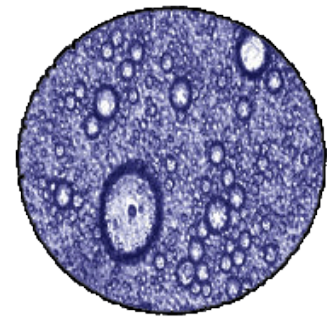

Microscopical view of raw milk

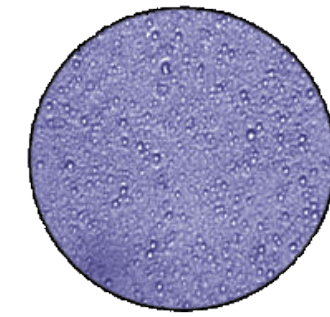

Microscopical view of homogenized milk

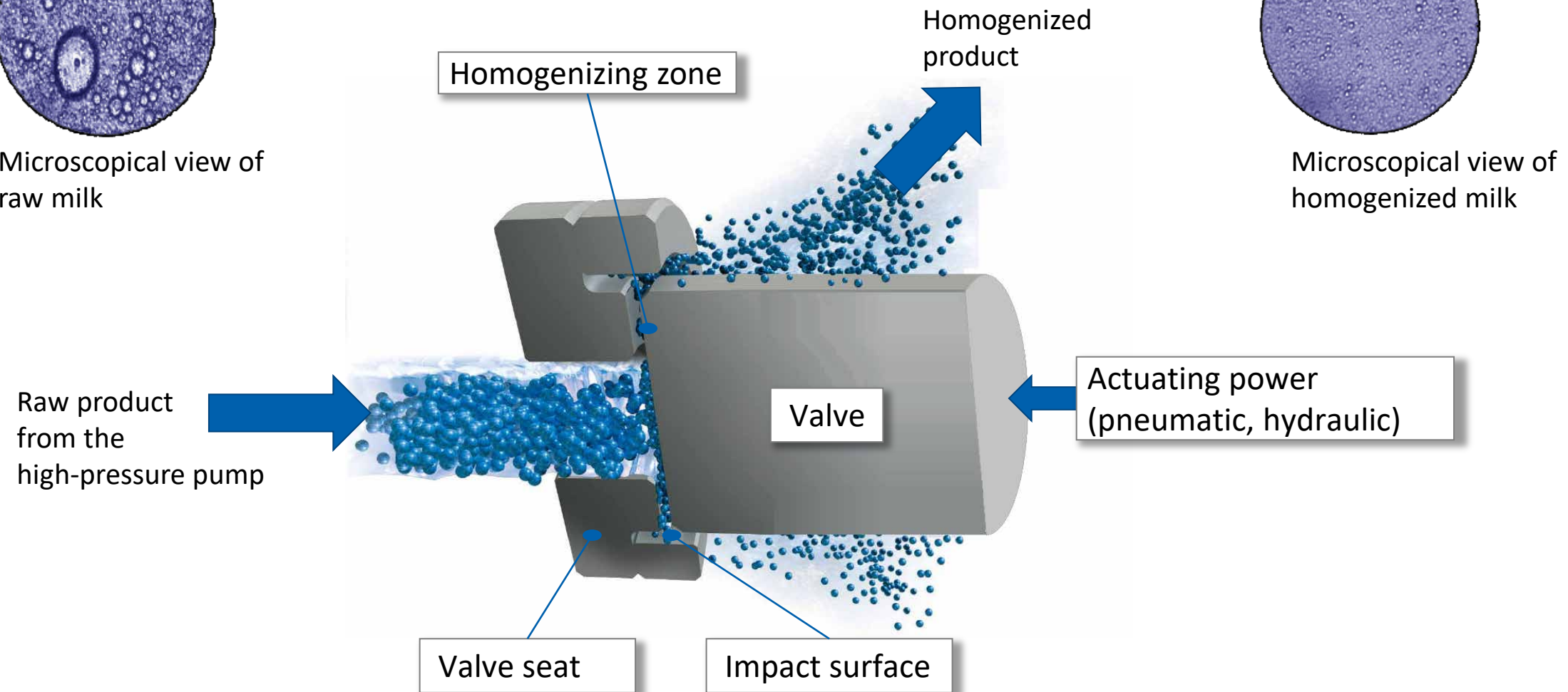

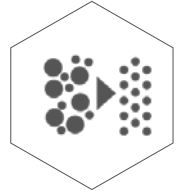

HST homogenizing valve technology

- Design in accordance with the **latest hygienic standard**
- Standardised modular component system
- Valve geometries and materials in line with the product
- Pneumatic pressure setting up to 35 mm (HL1 – HLI90)
- Hydraulic pressure setting > 35 mm (HL4 – HL8)
- MultiGap™ multi-gap valve from 10,000 l/h for dairy products

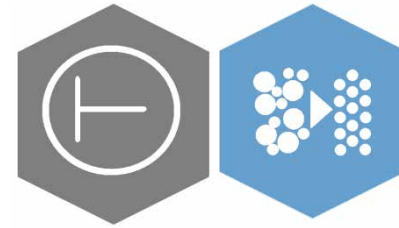

MultiGap™

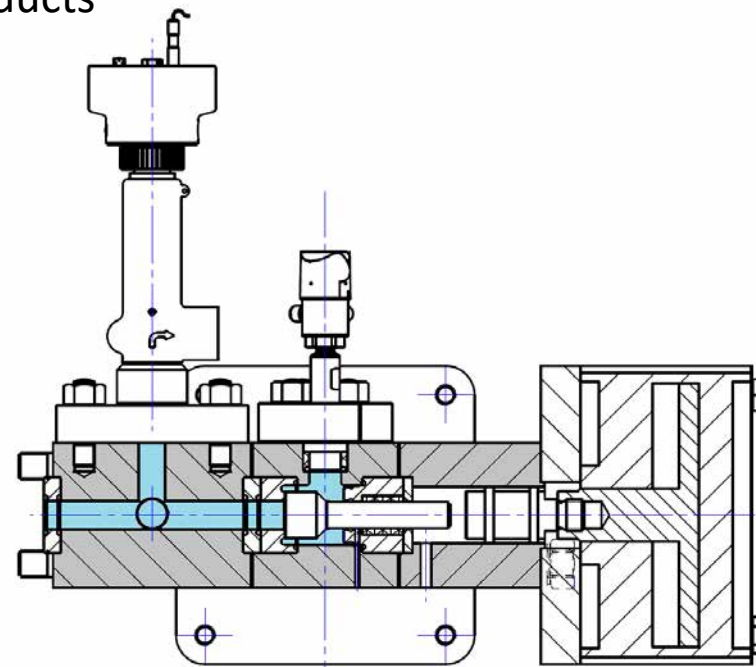

20 – 35 mm

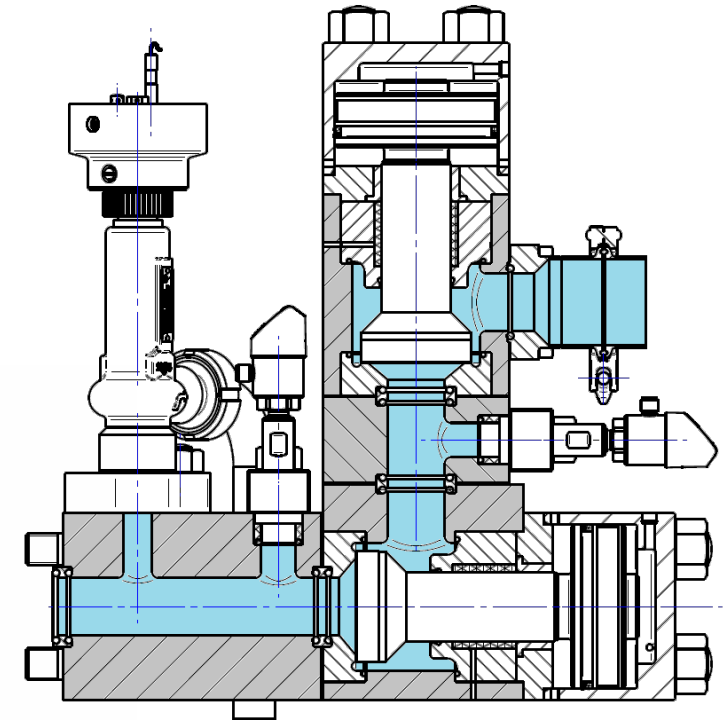

50 – 80 mm

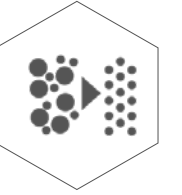

Model range HLI55 – HLI75 – HLI90

- Compact drive for 150 kW/200 PS with max. 90 kW power load
- Internal lubrication, no cooling water, no auxiliary units
- Hygienic design, 3-A compliant
- Pneumatic homogenizing valve adjustment
- Aseptic design optional
- Sound reduction cabinet

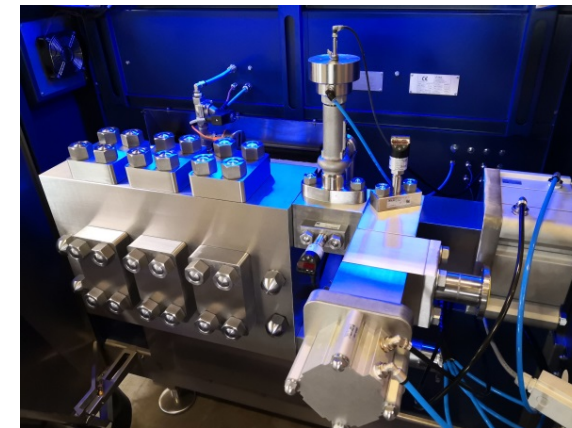
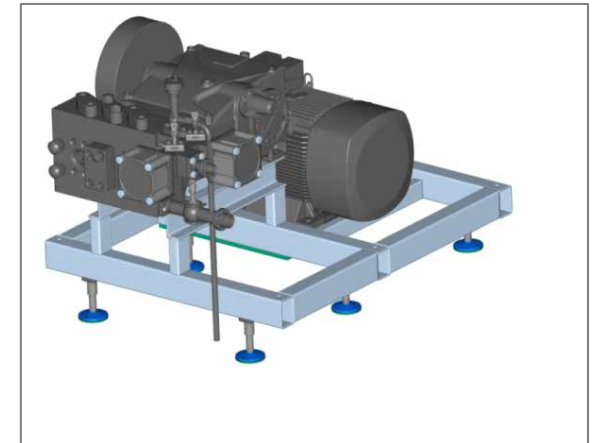

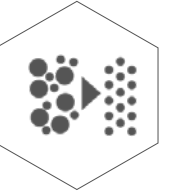

Aseptic design of homogenizers

- Sterile barriers serial with robust seals
- Temperature measurement and flow monitoring at discharge
- Can be sterilised with hot water or pure steam
- Sterile-water generating system optionally available

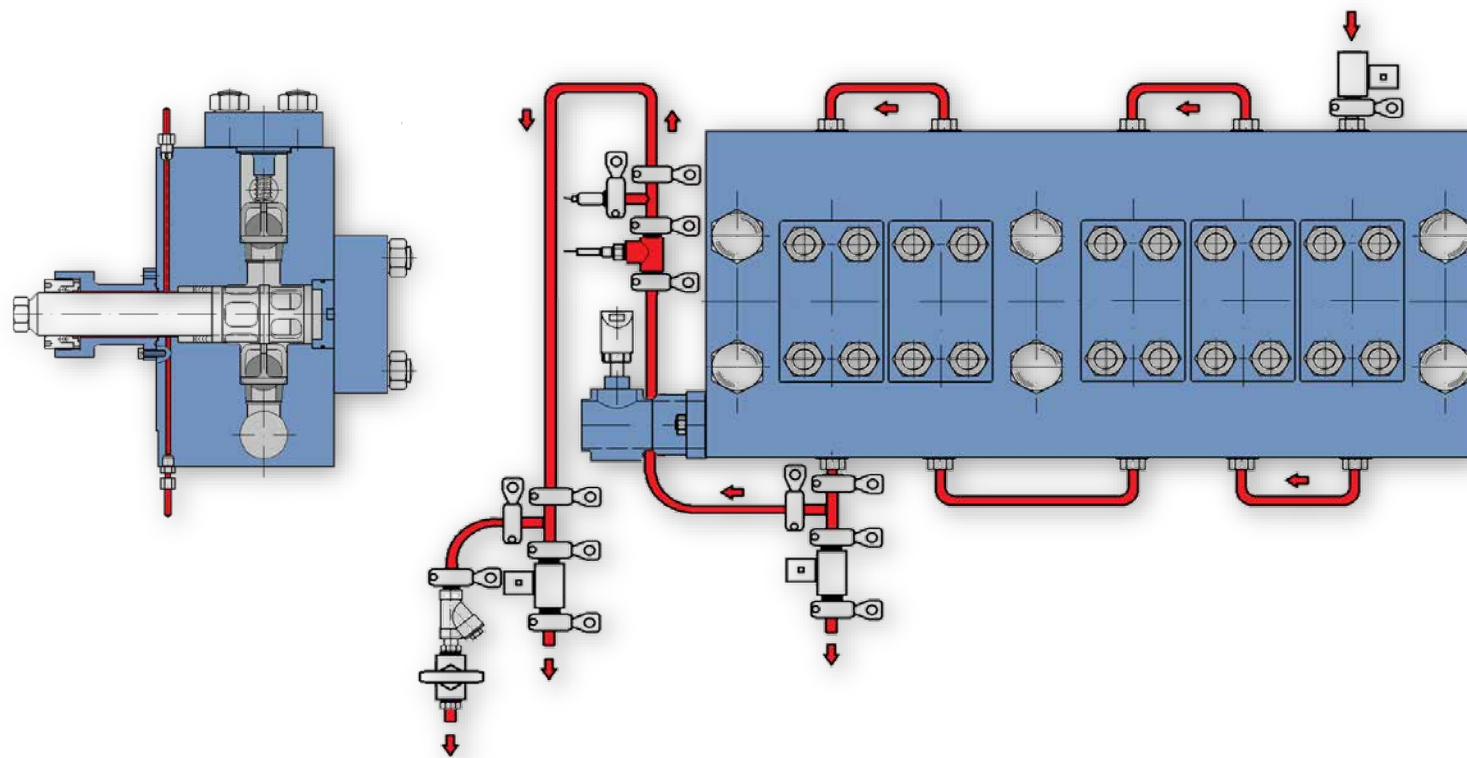

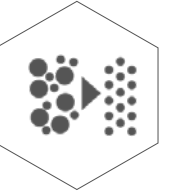

HST homogenizers for the hazard atmospheres (ATEX)

- Use for zone 1 (ATEX) 2014/34/EC
- **Ex II 2G / Ex h IIB T3 Gb**
- Temperature class T3 (200 °C)
- ATEX certificate and documentation

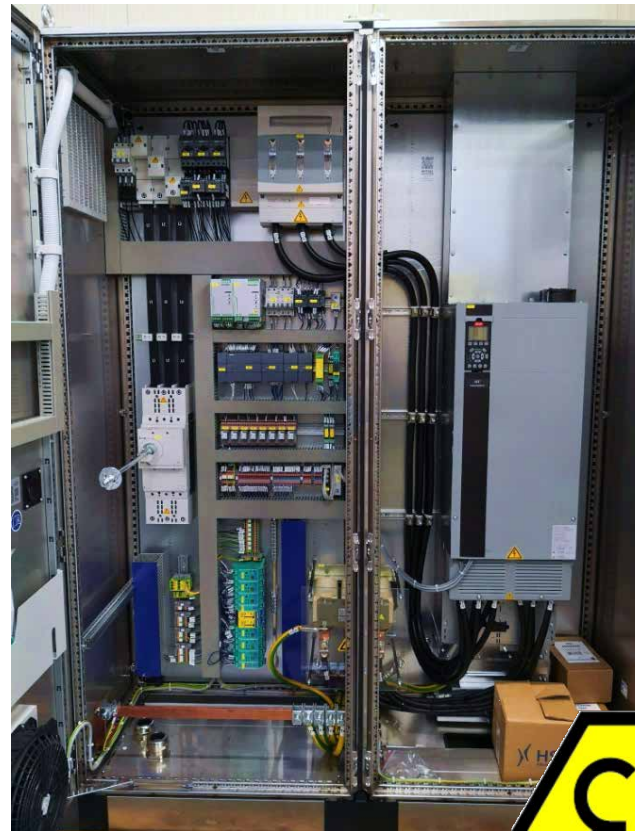
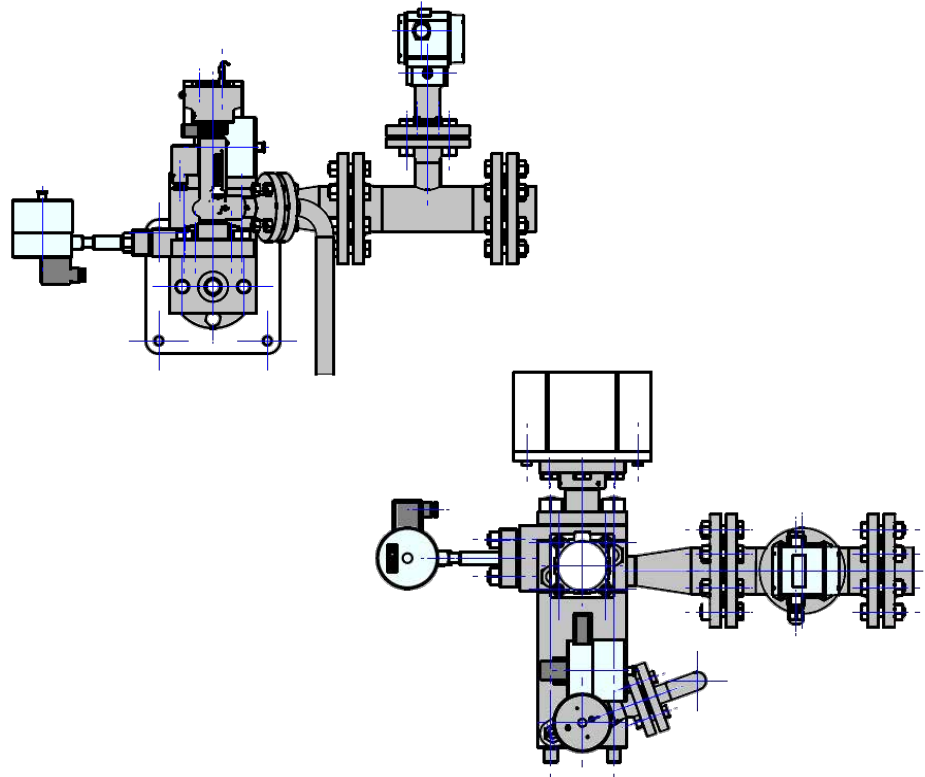

HST Maschinenbau GmbH Zündgefahrenbewertung für Homogenisator nach ISO EN 80079-36:2016 und EN 60079-0

HST Maschinenbau GmbH Zündgefahrenbewertung für Homogenisator nach ISO EN 80079-36:2016 und EN 60079-0

HST Maschinenbau GmbH Zündgefahrenbewertung für Homogenisator nach ISO EN 80079-36:2016 und EN 60079-0

Hochdruck Homogenisator Typ HA.4000X, TAG: Serien-Nr. 1924645													
Zündgefahr		Bewertung der Möglichkeit des Auftretens einer Zündquelle				Eingeleitete Maßnahmen zur Verhinderung des Wirksamwerdens der Zündquelle				Häufigkeit des Auftretens einer Zündquelle			
		a	b	c	d	a		b		c		d	
1	Phasierbare Zündquelle	Beschreibung phasierbarer Zündquelle (z.B. Motor, Lichtbogen, etc.)	Beschreibung der eingesetzten Maßnahmen (z.B. Schutzgehäuse, Isolation, etc.)	Grundlegende Parameter (z.B. Schutzart, Temperaturklasse, etc.)	Technische Dokumentation (z.B. Prüfprotokolle, etc.)
1	Heiße Oberfläche	Kühlleistung an Hochdruckpumpe (z.B. 1000 W)
2	Heiße Oberfläche	Kühlleistung an Hochdruckpumpe (z.B. 1000 W)

Seite 1 von 7 Dokument: Zündgefahrenbewertung_Z_192464_000 Stand: 30.06.2019



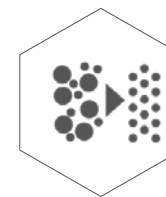

Automation and control cabinet construction

- Construction of control cabinets for homogenizers and other components
- Automation of homogenizers and systems
- Touch panel controller (HMI) for all HST homogenizers
- Controllers and touch-screens: Siemens or Rockwell

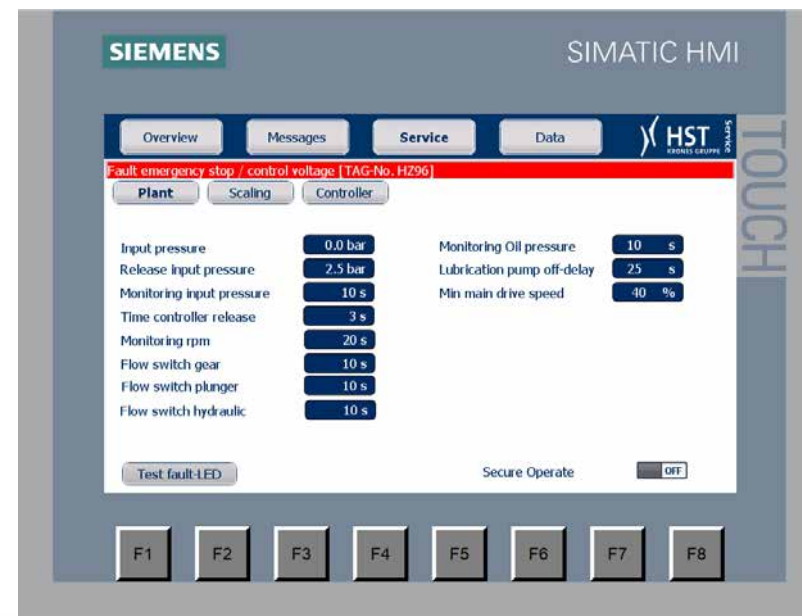
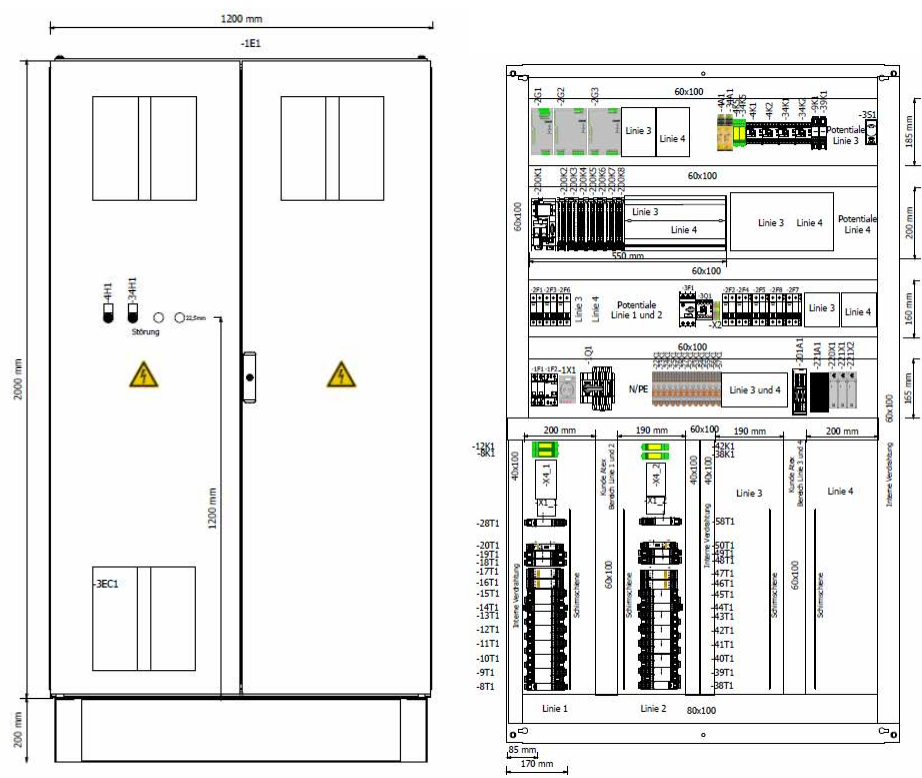

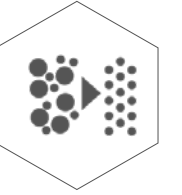

Pulsation dampener

- Calculation of dampener and stand pipes
- HST delivery program:
 - Wind chamber (sanitary), simple design
 - Inline damper with silicone inserts (also aseptic)

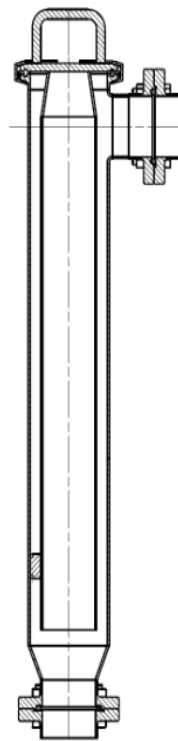
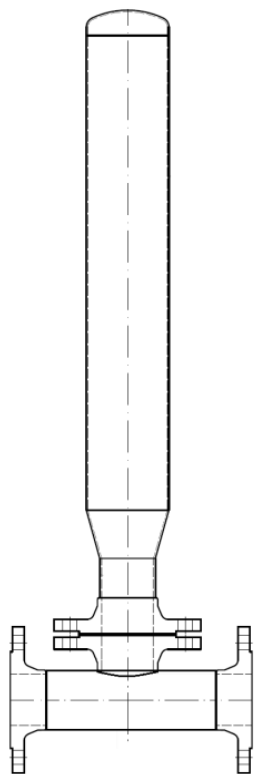

Direct gas inclusion in wind chamber system

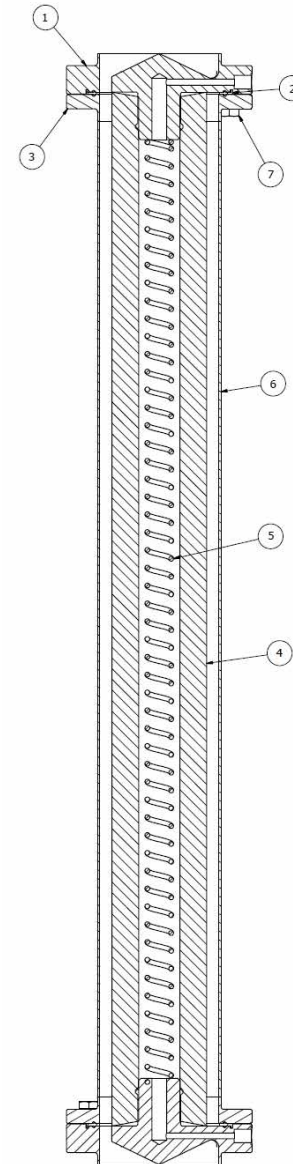

Material deforming silicone inserts



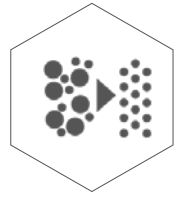

Wear and spare parts for homogenizers

HST homogenizers

We keep all wear parts in stock – spare parts, such as crankshafts, cylinder blocks or housings will be supplied on request.

Alfa homogenizers

Thanks to many years of experience with Alfa homogenizers, we are able to supply nearly all wear parts. Spare parts such as cylinder blocks, housings for homogenizing valves and various manufactured parts are manufactured at our factory on customer request.

GEA Niro Soavi and APV Rannie homogenizers

We will deliver the appropriate wear and spare parts on request.

APV Gaulin homogenizers

We have most APV homogenizer wear parts available. Spare parts such as cylinder blocks, housings for homogenizing valves and various manufactured parts are manufactured at our factory.



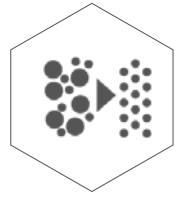

Benefits

Flexible thanks to our own production

Thanks to our high flexibility and a modern machinery, we are able to quickly react to customer requirements. We produce standard wear parts and special parts quickly and cost-efficiently.

From a single source

Through us, you are provided with most varying products of world-leading manufacturers in the area of high pressure homogenizers from one source.

Energy saving and efficient

The use of our innovative MultiGap valve saves up to 25 percent energy as compared to a standard valve.

High product quality

Throughout the complete production process, our products are subjected to a continuous quality assurance. We thereby grant you a continuously high product quality.

Our service

Our experience service team offers you competent consultation and ensures quick and unproblematic processing of your enquiries.

Our service hotline

- 24 hours daily
- Telephone: +49 (0) 38826 8878 77



Everything from a single source

Training sessions at the KRONES Academy – trained personnel increases your line efficiency

The versatile training offer ranges from operation, servicing and maintenance to management training. We will gladly also establish your individual training programme.

KIC KRONES cleaning agents make your machine shine

Only if the production environment is immaculate, can your product be brilliant. KIC KRONES provides you with the optimum cleaning agents and disinfectants for each individual production step.

KIC KRONES Lubricants for every production step

Whether for gears, chains or central lubrication systems – our greases and oils are true all-round talents. They can reach every lubrication point, protect your line and ensure gentle treatment for your products thanks to their food-grade quality.

KRONES Lifecycle Service – partner for performance

Also after having purchased a new machine, KRONES will take care of your line; the LCS experts are always ready to consult you and translate your goals and wishes into optimal LCS solutions.

EVOGUARD – excellent valve technology all along the line

The valve series of EVOGUARD comprises a modular system with hygienic and aseptic components which contributes to every point of the production line with increased performance and which has the perfect solution for every process step.

EVOGUARD – pumps for absolute process safety

In addition to the separation and locking of a line, one thing is particularly important - and that is the reliable conveyance of your product. This is why EVOGUARD also offers innovative centrifugal pumps in addition to high-quality valves.

